

(Revised January 15 2009)

INSTRUCTION MANUAL
MODEL 4200- S / 21
RF MICROWATTMETER

SERIAL NUMBERS 975 AND ABOVE

BOONTON
ELECTRONICS CORPORATION

791 ROUTE 10, RANDOLPH, NJ 07869
TELEPHONE: 201 — 584-1077 TWX: 710-986-8215

7 / 87

P/N 99100600D

Printed in U.S.A.

SAFETY SUMMARY

The following general safety precautions must be observed during all phases of operation and maintenance of this instrument. Failure to comply with these precautions or with specific warnings elsewhere in this manual violates safety standards of design, manufacture, and intended use of the instrument. Boonton Electronics assumes no liability for the customer's failure to comply with these requirements.

THE INSTRUMENT MUST BE GROUNDED

To minimize shock hazard the instrument chassis and cabinet must be connected to an electrical ground. The instrument is equipped with a three conductor, three prong a.c. power cable. The power cable must either be plugged into an approved three-contact electrical outlet or used with a three-contact to a two-contact adapter with the (green) grounding wire firmly connected to an electrical ground at the power outlet.

DO NOT OPERATE THE INSTRUMENT IN AN EXPLOSIVE ATMOSPHERE.

Do not operate the instrument in the presence of flammable gases or fumes.

KEEP AWAY FROM LIVE CIRCUITS.

Operating personnel must not remove instrument covers. Component replacement and internal adjustments must be made by qualified maintenance personnel. Do not replace components with the power cable connected. Under certain conditions dangerous voltages may exist even though the power cable was removed, therefore: always disconnect power and discharge circuits before touching them.

DO NOT SERVICE OR ADJUST ALONE.

Do not attempt internal service or adjustment unless another person, capable of rendering first aid and resuscitation, is present.

DO NOT SUBSTITUTE PARTS OR MODIFY INSTRUMENT.

Do not install substitute parts or perform any unauthorized modification of the instrument. Return the instrument to Boonton Electronics for repair to ensure that the safety features are maintained.

SAFETY SYMBOLS.



This safety requirement symbol (located on the rear panel) has been adopted by the International Electrotechnical Commission, Document 66 (Central Office) 3, Paragraph 5.3, which directs that an instrument be so labeled if, for the correct use of the instrument, it is necessary to refer to the instruction manual. In this case it is recommended that reference be made to the instruction manual when connecting the instrument to the proper power source. Verify that the correct fuse is installed for the power available, and that the switch on the rear panel is set to the applicable operating voltage.

CAUTION

The CAUTION sign denotes a hazard. It calls attention to an operation procedure, practice, or the like, which, if not correctly performed or adhered to, could result in damage to or destruction of part or all of the equipment. Do not proceed beyond a CAUTION sign until the indicated conditions are fully understood and met.

WARNING

The WARNING sign denotes a hazard. It calls attention to an operation procedure, practice, or the like, which, if not correctly performed or adhered to, could result in injury or loss of life. Do not proceed beyond a WARNING sign until the indicated conditions are fully understood and met.



Indicates dangerous voltages.

TABLE OF CONTENTS

SECTION I - INTRODUCTION

Paragraph		Page
1-1	Introduction	1-1
1-3	Description	1-1
1-7	Accessories	1-2
1-11	Options	1-2
1-15	Specifications	1-3
1-17	Outline Dimensions	1-3

SECTION II - INSTALLATION

Paragraph		Page
2-1	Introduction	2-1
2-3	Installation	2-1
2-4	Unpacking	2-1
2-5	Mounting	2-1
2-6	Power Requirements	2-1
2-7	Cable Connections	2-1

SECTION III - OPERATION

Paragraph		Page
3-1	Introduction	3-1
3-3	Operating Controls, Indicators and Connectors	3-1
3-5	Sensor Calibration Data	3-1
3-7	Power Application	3-1
3-9	Preliminary Checkout	3-1
3-11	Operating Instructions	3-5
3-12	Measurement Parameters	3-5
3-13	Use of Numerical Keys	3-5
3-14	SELECT Function	3-5
3-15	MODE Selection	3-6
3-16	RANGE Selection	3-6
3-17	LIMITS dB Selection	3-6
3-18	CAL FACTOR Selection	3-6
3-19	REF LEVEL dB Selection	3-7
3-20	Entry Limits	3-7
3-21	Recall of Entered Values	3-7
3-22	Zeroing the Instrument	3-8
3-23	Calibrating the Instrument	3-8
3-24	Error Messages	3-9
3-25	Measurements	3-9
3-26	Making Power Measurements	3-9
3-27	Low-Level Measurements	3-9
3-28	High-Level Measurements	3-9
3-29	High-Frequency Measurements	3-9
3-30	Temperature Effects	3-9
3-31	SWR Measurements	3-9
3-32	Shielding Recommendations	3-11
3-33	Analog Output	3-11
3-34	Minimum Performance Standards	3-12
3-35	Test Equipment Required	3-12
3-36	Preliminary Setup	3-12
3-37	Automatic Zero Function Test	3-12
3-38	Autoranging Mode Test	3-12
3-39	Range Hold Function Test	3-12
3-40	Basic Instrument Accuracy Test	3-13
3-41	Power Mode Test	3-13
3-42	Calibration Test	3-13

SECTION III - OPERATION (Cont.)

Paragraph		Page
3-43	Sensor Selection Test	3-14
3-44	dB Reference Level Function Test	3-14
3-45	dB Limit Test	3-14
3-46	Calibration Factor Test	3-14

SECTION IV - THEORY OF OPERATION

Paragraph		Page
4-1	Introduction	4-1
4-4	Overall Block Diagram	4-1
4-5	Sensor	4-1
4-6	Input Module	4-1
4-7	Control Module	4-1
4-8	Display Module	4-1
4-9	Power Reference	4-1
4-10	Power Supply Module	4-1
4-11	Optional Modules	4-1
4-12	Detailed Theory of Operation, Sensor Circuits	4-2
4-15	Detailed Theory of Operation, Input P.C. Board Circuits	4-2
4-26	Detailed Theory of Operation, Control P.C. Board	4-4
4-34	Detailed Theory of Operation, Display P.C. Board	4-10
4-41	Detailed Theory of Operation, Power Reference P.C. Board	4-10
4-44	Detailed Theory of Operation, Power Supply P.C. Board	4-13

SECTION V - MAINTENANCE

Paragraph		Page
5-1	Introduction	5-1
5-3	Safety Requirements	5-1
5-5	Test Equipment Required	5-1
5-7	Troubleshooting Concept	5-1
5-9	Signature Analysis	5-1
5-15	Trouble Localization	5-2
5-16	Gaining Access to Internal Component	5-2
5-17	Visual Inspection	5-2
5-18	Use of Block Diagrams	5-2
5-19	Systematic Troubleshooting	5-2
5-20	Signature Analysis Free-Running Test Procedures	5-3
5-22	Signature Analysis Programmed Test Procedures	5-3
5-24	Non-Volatile RAM Circuit Tests	5-10
5-25	Non-Volatile RAM Test	5-10
5-26	Non-Volatile RAM Cell Test	5-17
5-27	Non-Volatile RAM Cell Replacement	5-17
5-28	Instrument Adjustments	5-18
5-29	General	5-18
5-30	Power Supply Adjustments	5-18
5-31	Input Module Adjustments	5-18
5-32	DC Calibration	5-20
5-33	AC Calibration	5-21
5-34	Display Board Recorder Output Adjustment	5-22
5-35	Power Reference Adjustment	5-25
5-36	Entry of Sensor Calibration Factors Versus Frequency	5-25
5-37	Sensor Calibration	5-26
5-38	General	5-26
5-39	Bit Switch Setting for Additional Sensor	5-26
5-40	Calibration of Model 4200-4C Sensor	5-26
5-41	Calibration Notes, Model 4200-6 Sensor + 30 dBm Range	5-27

SECTION VI - PARTS LIST

Paragraph	Page
Table of Replaceable Parts	6-1

SECTION VII - SCHEMATIC DIAGRAMS

Paragraph	Page
Schematic Diagrams	7-1

APPENDIX A – IEEE-488 BUS INTERFACE OPTION 4200-01A

APPENDIX B – IEEE-488 BUS INTERFACE OPTION 4200-01B

APPENDIX C – INPUT CHANNEL 2 OPTION 4200-03

APPENDIX D – REAR INPUT OPTION 4200-04

APPENDIX E – INTERNAL TMA (MATE) OPTION 4200-06

APPENDIX F – REAR INPUT OPTION 4200-S/17

LIST OF ILLUSTRATIONS

Figure	Page
1-1 Model 4200 RF Microwattmeter	vi
1-2 Outline Dimensions	1-11
2-1 Packaging Diagram	2-1
3-1 Front View of Instrument	3-2
3-2 Rear View of Instrument	3-2
3-3 Typical Temperature Characteristics of Series 4200 Sensors	3-10
3-4 Typical Combined Temperature Characteristics of Instrument and Sensor	3-10
3-5 dB-SWR Conversion Chart	3-11
4-1 Overall Block Diagram	4-2
4-2 Typical Series 4200 Sensor, Schematic Diagram	4-3
4-3 Input P.C. Board, Detailed Block Diagram	4-5
4-4 Control P.C. Board, Detailed Block Diagram	4-7
4-5 Display P.C. Board, Detailed Block Diagram	4-11
4-6 Power Reference P.C. Board, Detailed Block Diagram	4-13
4-7 Power Supply P.C. Board, Detailed Block Diagram	4-15
5-1 Location of Major Assemblies (Sheet 1 of 2)	5-4
5-1 Location of Major Assemblies (Sheet 2 of 2)	5-5
5-2 Input P.C. Board, Voltage and Waveform Data	5-6
5-3 Control Board Bit Switch Settings	5-7
5-4 Non-Volatile RAM Cell Test and Connection Points	5-18
5-5 Test Setup for Input Module Offset, Chopper, and A/D Converter Adjustments	5-20
5-6 Test Setup for Recorder Output Adjustment	5-21
5-7 Test Setup for Determination of Attenuation Value	5-28
5-8 Calibration Test Setup, Model 4200-6 Sensor, + 30 dBm Range	5-28

LIST OF TABLES

Table		Page
1-1	Performance Specifications	1-3
1-2	Sensor Characteristics	1-8
1-3	Maximum Response Chart for Series 4200-A Sensors	1-9
3-1	Operating Controls, Indicators and Connectors	3-3
3-2	Instrument Zeroing Time	3-8
5-1	Test Equipment List	5-1
5-2	Control Board Address Field Test	5-8
5-3	Control Board Memory Decoding Test	5-8
5-4	Control Board I/O Decoding Test	5-9
5-5	Control Board ROM 0 Test	5-9
5-6	Control Board ROM 1 Test	5-9
5-7	Interface Board ROM 2 Test	5-10
5-8	Control Board 4ABIO Test	5-11
5-9	Control Board 4CIO Test	5-11
5-10	Control Board 4DIO Test	5-11
5-11	Display Visual Test	5-12
5-12	Control Board Display Test	5-12
5-13	Control Board Display Scan Test	5-12
5-14	Keyboard Visual Test	5-13
5-15	Control Board RAM Test	5-13
5-16	Input Module, Channel 1 0AIO Test	5-14
5-17	Input Module, Channel 1 0BIO Test	5-14
5-18	Input Module, Channel 1 0CIO Test	5-15
5-19	Input Module, Channel 1 0DIO Test	5-15
5-20	Input Module, Channel 2 1AIO Test	5-15
5-21	Input Module, Channel 2 1BIO Test	5-16
5-22	Input Module, Channel 2 1CIO Test	5-16
5-23	Input Module, Channel 2 1DIO Test	5-17
5-24	DC Calibration Test	5-22
5-25	Full Scale Sensor Calibration Data for 4A, 4B, 4C, 4E, 5B*, 5E*, 5G, 6E*, 7E, and 8E* Series Sensors	5-23
5-26	Down Scale Sensor Calibration Data for 4A, 4B, 4C, 4E, 5B*, 5E*, 5G, 6E*, 7E, and 8E* Series Sensors	5-24
5-27	Down Scale Connection Data	5-24
5-28	Typical Calibration Data for Model 4200-6 with Model 4200	5-26

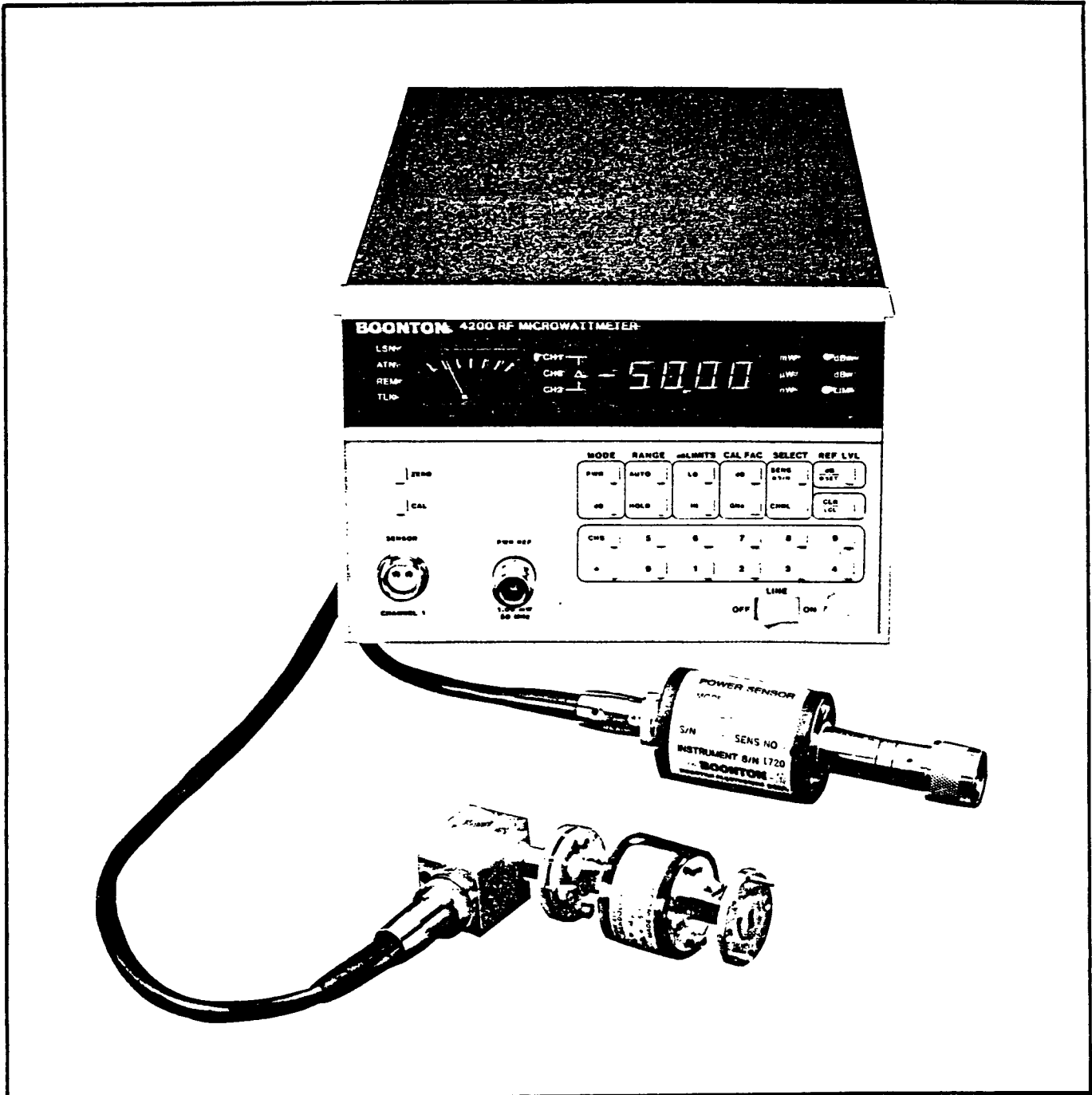

Figure 1-1 Model 4200 RF Microwattmeter

SECTION I

INTRODUCTION

1-1. INTRODUCTION.

1-2. This instruction manual provides general information, installation and operating instructions, theory of operation, maintenance instructions and parts list for the Model 4200 RF Microwattmeter.

1-3. DESCRIPTION.

1-4. The Model 4200 is a microprocessor-based solid state RF microwattmeter. The instrument is capable of measuring RF power levels from 1 nW (-60 dBm) to 1W (+30 dBm) for a frequency range of 0.2 MHz to 110 GHz. The instruments calibrated power level and frequency range is determined by the Series 4200 sensor used with the instrument. The Series 4200 sensors are accessories and must be ordered per application. Refer to Table I-2 for the Series 4200 sensor characteristics.

1-5. The Model 4200 is designed to perform the following operations:

- a. Low-power transmitter, signal generator, and oscillator measurements.
- b. SWR and return-loss measurements with directional couplers and slotted lines.
- c. Gain and insertion loss measurements.
- d. RF attenuation and SWR measurements.
- e. Antenna measurements.

1-6. The Model 4200 design features are as follows:

a. **Wide Frequency Range:** 0.2 MHz to 110 GHz. The calibrated frequency range of the instrument is determined by the sensor utilized. Refer to Table I-2.

b. **Wide Power Range.** Depending on the selected sensor, the instrument will measure RF power from 1 nW up to 1W. Temporary overloads up to 300 mW with Series 4200-4 sensors and up to 2W with Series 4200-5 sensors will do no permanent harm to the instrument or the sensor.

When measuring pulsed signals, the power indications are accurate up to 20 microwatts peak power (200 microwatts with Series 4200-5 sensors). External attenuators may be used to extend the measurement range of the instrument.

c. **Low Noise.** The instrument has been designed and constructed to minimize noise from all sources. The sensor cable is of a special low-noise design; vigorous flexing causes only momentary minor deflections on the most sensitive range of the instrument. The sensors are insensitive to shock and vibration; even sharp tapping on the sensor barrel causes no visible deflection on any range. Internal signal amplification occurs at approximately 94 Hz thereby reducing susceptibility to 50 or 60 Hz fields. A low-noise solid-state chopper is used.

d. **LED Display.** Measured power levels are displayed by a 4 digit, LED type readout with decimal points and minus sign. Annunciators associated with the LED display indicate the units of measurement. The result is a clear, unambiguous readout that minimizes the possibility of misinterpretation. The display is also used to show data being entered into non-volatile memory and to display data recalled from non-volatile memory; the display and annunciators blink on and off during data entry and recall to indicate that displayed values are not measured values.

e. **Analog Indications.** A front-panel analog meter provides relative power indications for peaking or nulling applications. A dc voltage proportional to the measured power level is available at a rear-panel connector for application to a recorder or other external device.

f. **Pushbutton Measurement Mode Selection.** A choice of measurement modes is available to the operator. Indications in terms of power or dBm can be selected by pressing the appropriate front-panel key switch. A dB reference level can be entered through the keyboard and a display mode selected to indicate power levels in dB, relative to a dB reference level.

g. **Automatic Ranging.** Autoranging under control of the microprocessor eliminates the need for manual ranging. Alternately, a measurement range can be retained for all measurements, if desired, by selecting the range hold mode.

Section I Introduction

Applications of power levels that exceed the maximum or minimum measurement capability of the instrument (or range in the hold mode) results in an error indication on the LED display.

h. **Automatic Zeroing.** An automatic zeroing circuit eliminates the need for tedious, often inaccurate, manual zeroing. With zero input to the sensor, pressing a front-panel key switch directs the microprocessor to compute and store zero corrections for each range, and the instrument is thereafter corrected on each range in accordance with the stored data. This method is considerably simpler, faster, and more accurate than manual zeroing.

i. **Automatic Sensor Compensation.** Calibration factors for up to eight sensors may be stored in the microprocessor. Calibration data is written into non-volatile storage at the factory for sensors ordered with the instrument; calibration data may also be written into storage in the field. When the sensor being used and the measurement frequency are specified through front-panel keyboard entry, measurement values are corrected automatically with calibration factors. Alternately, the calibration factor in dB for a particular sensor being used may be entered through the keyboard, and the measurement values are then corrected automatically in accordance with the correction factor. Both power and dB values are corrected.

j. **Built-in Power Reference.** An accurate, 1.000 milliwatt, 50 MHz signal for instrument calibration is provided by a built-in power reference. Calibration is simply a matter of connecting the sensor to the power reference, and pressing a key; the calibration correction is computed automatically by the microprocessor. The calibration circuit has built-in protection against inadvertent key actuation when the sensor is not connected to the power reference; calibration correction is limited to approximately 7.5% from the original factory set value. Computed calibration corrections that exceed this range are rejected automatically, and the instrument returns to its previous sensitivity. If the instrument is supplied with a 75-ohm sensor (4200-4C) an adapter (P/N 950006) is also supplied. This adapter is used between the power reference and the sensor to convert the Type N power reference connector to a 75-ohm Type N. Before calibration, a 0.17 dB CAL FACTOR should be entered to compensate for the mismatch error that is introduced by the 75-ohm sensor.

k. **Pushbutton High/Low dB Limit Selection.** High/low dB limits may be entered through the front-panel keyboard. A front-panel annunciator indicates when measured dB levels are outside the preset limits. Signals are also activated at a rear-panel connector to provide remote indications of out-of-limit measurements.

l. **Solid-state Chopper.** Signal amplification in the instrument occurs at approximately 94 Hz. Input signals from the sensor are converted into a 94 Hz signal by a solid-state, low-level input modulator (chopper), which represents a distinct improvement over electromechanical choppers. Extended service life is assured through the elimination of contact wear, contamination, and other problems associated with electromechanical choppers.

m. **Signature Analysis Maintenance.** Connection facilities to permit signature analysis maintenance are incorporated. Digital circuit troubles can be localized rapidly and accurately using the signature analysis maintenance technique, thereby reducing instrument down-time. A diagnostic ROM (P N 961003) is available from Boonton Electronics Corporation for signature analysis maintenance.

1-7. ACCESSORIES.

1-8. The following accessories are supplied with the instrument:

- a. AC power cord
- b. Sensor cable

1-9. The Series 4200 sensors are not supplied with the instrument and must be ordered. Refer to Table 1-2 for the sensor characteristics.

1-10. If the instrument is ordered with sensor(s) the sensor calibration data is programmed into the instrument at the factory. If additional sensor(s) are required after the instrument is in the field, the new sensor calibration data can be field installed.

1-11. OPTIONS.

1-12. The following options are available for the instrument:

- a. Rack mount hardware kits.
- b. -01A IEEE Bus Interface.
- c. -01B IEEE Bus interface.
- d. -03 Second Input Channel.
- e. -04 Rear Input.
- f. -06 Internal TMA (MATE). Requires -01B Option.
- g. -S/17 Two Inputs On Front Panel. Requires -03 Option.

1-13. Information concerning the Option is included in the Appendices of this manual.

1-14. Please direct all special instrument applications questions to the Applications Engineering Department of Boonton Electronics Corporation.

1-15. SPECIFICATIONS.

1-17. OUTLINE DIMENSIONS.

1-16. Performance specifications are listed in Table 1-1.

1-18. Outline dimensions of the instrument are shown in Figure 1-2.

TABLE 1-1. SENSOR CHARACTERISTICS

4B (51011)	100 kHz - 12.4 GHz, 50 Ω Coax			
4C (51012)	100 kHz - 1 GHz, 75 Ω Coax			
4E (51013)	100 kHz - 18 GHz, 50 Ω Coax			
4G (51051)	1 MHz - 26.5 GHz, 50 Ω Coax SMA			
5E (51015)	100 kHz - 18 GHz, 50 Ω Coax			
6E (51033)	100 kHz - 18 GHz, 50 Ω Coax			
7E (51016)	10 MHz - 18 GHz, 50 Ω Coax			
8E (51017)	10 MHz - 18 GHz, 50 Ω Coax			
4K (51035)	18 GHz - 26.5 GHz, Waveguide			
WRD-180 (51972)	18 GHz - 40 GHz, Waveguide			
4Ka (51036)	26.5 GHz - 40 GHz, Waveguide			
(51037)	33 GHz - 50 GHz, Waveguide			
4U (51045)	40 GHz - 60 GHz, Waveguide			
4V (51046)	50 GHz - 75 GHz, Waveguide			
4W (51047)	75 GHz - 110 GHz, Waveguide			

-60	-50	-40	-30	-20	-10	0	+10	+20	+30	+40 dBm
1nW	10nW	100nW	1μW	10μW	100μW	1mW	10mW	100mW	1W	10W



		
* True RMS	Transition Calibrated in RMS	Peak, Calibrated in RMS

TABLE 1-1. PERFORMANCE SPECIFICATIONS (Cont.)

Parameter	Specifications																																																														
RANGING	Autoranging plus hold on range																																																														
BASIC MEASUREMENT ACCURACY The total accuracy of the Model 4200 system, including sensor, is the sum of the uncertainties noted in sections A, B, C and D. These uncertainties may also be added in an RSS fashion which represents the most probable total uncertainty.	A. Basic Uncertainty (includes all instrumentation, noise, zero, and shaping errors and includes 0.7% power reference setting error)																																																														
RSS = $(A^2 + B^2 + C^2 + D^2)^{1/2}$	<table border="1" data-bbox="623 411 1463 1251"> <thead> <tr> <th rowspan="2">Sensor</th> <th rowspan="2">Input Level</th> <th colspan="2">Uncertainty</th> </tr> <tr> <th>Power</th> <th>dBm</th> </tr> </thead> <tbody> <tr> <td rowspan="2">4B/C/E/G</td> <td>> 10 nW</td> <td>1.2% rdg ± 0.1% fs</td> <td rowspan="10">see curves below</td> </tr> <tr> <td>< 10 nW</td> <td>1.5% rdg ± 1.5% fs</td> </tr> <tr> <td rowspan="2">5E</td> <td>> 100 nW</td> <td>1.2% rdg ± 0.1% fs</td> </tr> <tr> <td>< 100 nW</td> <td>1.5% rdg ± 1.5% fs</td> </tr> <tr> <td rowspan="2">6E</td> <td>> 1 μW</td> <td>1.2% rdg ± 0.1% fs</td> </tr> <tr> <td>< 1 μW</td> <td>1.5% rdg ± 1.5% fs</td> </tr> <tr> <td rowspan="2">7E</td> <td>> 10 μW</td> <td>1.2% rdg ± 0.1% fs</td> </tr> <tr> <td>< 10 μW</td> <td>1.0% rdg ± 3.0% fs</td> </tr> <tr> <td rowspan="2">8E</td> <td>> 100 μW</td> <td>1.2% rdg ± 0.1% fs</td> </tr> <tr> <td>< 100 μW</td> <td>1.0% rdg ± 3.0% fs</td> </tr> <tr> <td>4K</td> <td>10 μW (- 20 dBm) at 22 GHz</td> <td>± 6% rdg</td> <td>± 0.25*</td> </tr> <tr> <td>4KA</td> <td>10 μW (- 20 dBm) at 33 GHz</td> <td>± 13% rdg</td> <td>± 0.50*</td> </tr> <tr> <td>4Q</td> <td>10 μW (- 20 dBm) at 40 GHz</td> <td>± 13% rdg</td> <td>± 0.50*</td> </tr> <tr> <td>4U</td> <td>10 nW to 10 mW at 40 GHz to 60 GHz</td> <td>± 6% rdg</td> <td>± 0.25*</td> </tr> <tr> <td>4V</td> <td>10 nW to 10 mW at 50 GHz to 75 GHz</td> <td>± 6% rdg</td> <td>± 0.25*</td> </tr> <tr> <td>4W</td> <td>10 nW to 10 mW at 75 GHz to 110 GHz</td> <td>± 6% rdg</td> <td>± 0.25*</td> </tr> <tr> <td>WRD180</td> <td>10 nW to 10 mW at 18 GHz to 40 GHz</td> <td>± 6% rdg</td> <td>± 0.25*</td> </tr> </tbody> </table>			Sensor	Input Level	Uncertainty		Power	dBm	4B/C/E/G	> 10 nW	1.2% rdg ± 0.1% fs	see curves below	< 10 nW	1.5% rdg ± 1.5% fs	5E	> 100 nW	1.2% rdg ± 0.1% fs	< 100 nW	1.5% rdg ± 1.5% fs	6E	> 1 μW	1.2% rdg ± 0.1% fs	< 1 μW	1.5% rdg ± 1.5% fs	7E	> 10 μW	1.2% rdg ± 0.1% fs	< 10 μW	1.0% rdg ± 3.0% fs	8E	> 100 μW	1.2% rdg ± 0.1% fs	< 100 μW	1.0% rdg ± 3.0% fs	4K	10 μW (- 20 dBm) at 22 GHz	± 6% rdg	± 0.25*	4KA	10 μW (- 20 dBm) at 33 GHz	± 13% rdg	± 0.50*	4Q	10 μW (- 20 dBm) at 40 GHz	± 13% rdg	± 0.50*	4U	10 nW to 10 mW at 40 GHz to 60 GHz	± 6% rdg	± 0.25*	4V	10 nW to 10 mW at 50 GHz to 75 GHz	± 6% rdg	± 0.25*	4W	10 nW to 10 mW at 75 GHz to 110 GHz	± 6% rdg	± 0.25*	WRD180	10 nW to 10 mW at 18 GHz to 40 GHz	± 6% rdg	± 0.25*
Sensor	Input Level	Uncertainty																																																													
		Power	dBm																																																												
4B/C/E/G	> 10 nW	1.2% rdg ± 0.1% fs	see curves below																																																												
	< 10 nW	1.5% rdg ± 1.5% fs																																																													
5E	> 100 nW	1.2% rdg ± 0.1% fs																																																													
	< 100 nW	1.5% rdg ± 1.5% fs																																																													
6E	> 1 μW	1.2% rdg ± 0.1% fs																																																													
	< 1 μW	1.5% rdg ± 1.5% fs																																																													
7E	> 10 μW	1.2% rdg ± 0.1% fs																																																													
	< 10 μW	1.0% rdg ± 3.0% fs																																																													
8E	> 100 μW	1.2% rdg ± 0.1% fs																																																													
	< 100 μW	1.0% rdg ± 3.0% fs																																																													
4K	10 μW (- 20 dBm) at 22 GHz	± 6% rdg	± 0.25*																																																												
4KA	10 μW (- 20 dBm) at 33 GHz	± 13% rdg	± 0.50*																																																												
4Q	10 μW (- 20 dBm) at 40 GHz	± 13% rdg	± 0.50*																																																												
4U	10 nW to 10 mW at 40 GHz to 60 GHz	± 6% rdg	± 0.25*																																																												
4V	10 nW to 10 mW at 50 GHz to 75 GHz	± 6% rdg	± 0.25*																																																												
4W	10 nW to 10 mW at 75 GHz to 110 GHz	± 6% rdg	± 0.25*																																																												
WRD180	10 nW to 10 mW at 18 GHz to 40 GHz	± 6% rdg	± 0.25*																																																												
When operated as a dual-channel instrument (option - 03), total uncertainties of A must be multiplied by a factor of two.	* ± 0.01 dB/10 dBm relative to - 20 dBm																																																														

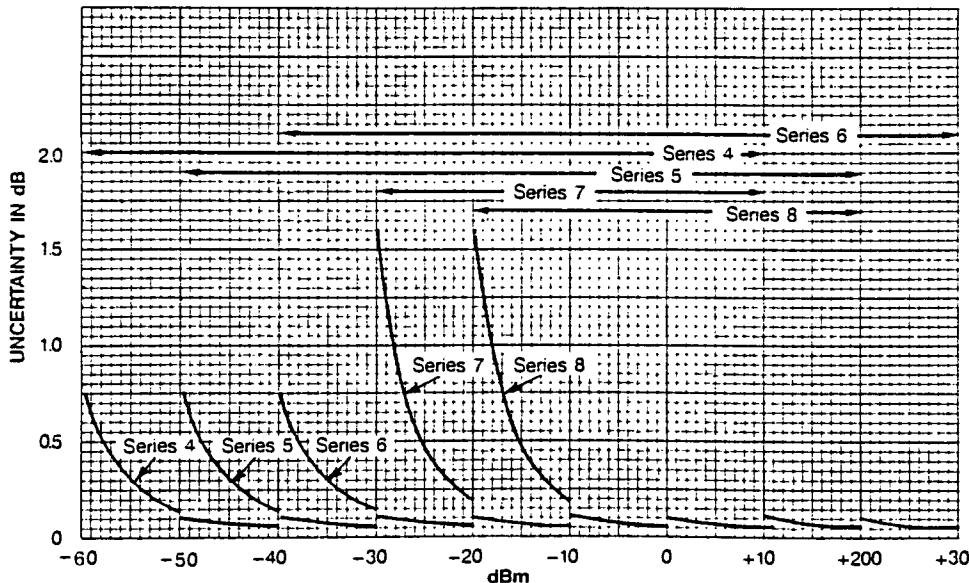

TABLE 1-1. PERFORMANCE SPECIFICATIONS (Cont.)

Parameter	Specifications																				
B. Temperature Uncertainty (at 1 MHz)																					
	Temperature	Instrument	Uncertainty All Sensors																		
	21°C to 25°C (reference)	0% (0 dB)	0% (0 dB)																		
	18°C to 30°C	0% (0 dB)	±2.32% (± 0.1 dB)																		
	10°C to 40°C	±4.7% (±0.2 dB)	±4.7% (±0.2 dB)																		
	0°C to 55°C	±5% (±0.25 dB)																			
C. Calibration Factor Uncertainty																					
Coaxial Sensor Calibration Factor Uncertainty																					
Sensor	Frequency GHz																				
	.05*	< 2	2	3	4	5	6	7	8	9	10	11	12	13	14	15	16	17	18	19-26.5	
4B (51011)																					
Max. %	0	1.3	3.0	3.0	3.5	3.5	3.5	3.5	4.0	4.0	4.0	4.5	4.5								
RSS %	0	1.3	1.7	1.7	1.7	1.8	1.9	2.0	2.1	2.5	2.5	2.4	3.0								
4C (51012)																					
Max. %	0	1.3																			
RSS %	0	1.3																			
4E (51013)																					
Max. %	0	1.3	3.0	3.0	3.5	3.5	3.5	3.5	4.0	4.0	4.0	4.5	4.5	6.0	6.0	6.0	6.0	6.0	6.0	6.0	6.0
RSS %	0	1.3	1.8	1.8	1.8	1.9	2.0	2.0	2.2	2.6	2.5	2.7	3.0	3.4	3.1	3.2	3.3	3.1	3.1	3.4	
4G (51051)																					
Max. %	0	1.3	3.0	3.0	3.5	3.5	3.5	3.5	4.0	4.0	4.0	4.0	4.5	6.0	6.0	6.0	6.0	6.0	6.0	6.0	6.0
RSS %	0	1.3	1.7	1.7	1.7	1.7	1.8	1.9	2.0	2.4	2.3	2.2	2.6	3.0	2.8	2.8	2.9	2.8	2.8	3.1	3.4
5E (51015)																					
Max. %	0	1.3	3.0	3.0	3.5	3.5	3.5	3.5	4.0	4.0	4.0	4.0	4.5	6.0	6.0	6.0	6.0	6.0	6.0	6.0	6.0
RSS %	0	1.3	1.7	1.7	1.7	1.7	1.8	1.9	2.0	2.4	2.3	2.2	2.8	3.0	2.8	2.8	2.9	2.8	2.8	3.1	
6E (51033)																					
Max. %	0	1.3	3.0	3.0	3.5	3.5	3.5	3.5	4.0	4.0	4.0	4.0	4.5	6.0	6.0	6.0	6.0	6.0	6.0	6.0	6.0
RSS %	0	1.3	1.7	1.7	1.7	1.7	1.8	1.9	2.0	2.4	2.3	2.2	2.8	3.0	2.8	2.8	2.9	2.8	2.8	3.1	
7E (51016)																					
Max. %	0	1.3	3.0	3.0	3.5	3.5	3.5	3.5	4.0	4.0	4.0	4.0	4.5	6.0	6.0	6.0	6.0	6.0	6.0	6.0	6.0
RSS %	0	1.3	1.8	1.8	1.8	1.8	1.9	2.0	2.1	2.5	2.4	2.6	2.9	3.3	3.1	3.1	3.2	3.0	3.4		
8E (51017)																					
Max. %	0	1.3	3.0	3.0	3.5	3.5	3.5	3.5	4.0	4.0	4.0	4.0	4.5	6.0	6.0	6.0	6.0	6.0	6.0	6.0	6.0
RSS %	0	1.3	1.8	1.8	1.8	1.8	1.9	2.0	2.1	2.5	2.4	2.6	2.9	3.3	3.1	3.1	3.2	3.0	3.4		
* Reference Frequency = 50 MHz. Note: CAL Factors are supplied at every 1 GHz.																					
Waveguide Sensor Calibration Factor Uncertainty																					
Sensor	Ref. GHz	At Ref. Freq.	Over Sensor BW	Sensor	Ref. GHz	At Ref. Freq.	Over Sensor BW	Sensor	Ref. GHz	At Ref. Freq.	Over Sensor BW	Sensor	Ref. GHz	At Ref. Freq.	Over Sensor BW						
4K (51035)	22	6	6	4Q (51037)	40	10	13	4V (51046)	60	12	13	WRD-180 (51972)	33								
Max. %		5	5	Max. %		6	7	Max. %		6	9					Max. %					
RSS %				RSS %				RSS %				RSS %		6	10						
4Ka (51036)	33	6	10	4U (51045)	40	10	13	4W (51047)	94	12	13			5	7						
Max. %		5	7	Max. %		6	8	Max. %		9	11										
RSS %				RSS %				RSS %													
Note: For waveguide sensors, the reference calibration is at -20 dBm.																					
D. Power Reference Uncertainty. Power reference accuracy is ±1.2% worst case for one year (0° to 55°C). When calculating the sum of the uncertainties, only include 0.5% for the power reference as the remaining 0.7% is included in A above.																					

TABLE 1-1. PERFORMANCE SPECIFICATIONS (Cont.)

Parameter	Specifications
POWER REFERENCE	
Source	Internal 50 MHz oscillator with Type N female connector on front panel.
Power output	1.00 mW, factory set to $\pm 0.7\%$, traceable to National Bureau of Standards, $\pm 1.2\%$ worst cast for one year (0° to 55° C).
CALIBRATION	Front panel key automatically calibrates instrument to power reference.
ZERO	Automatic, operated by front-panel switch.
CALIBRATION FACTOR	+ 3.0 dB to - 3.0 dB ranges in 0.01 dB steps, entered through front panel keys; alternately, stored calibration factors are interpolated linearly and applied automatically to readings when the frequency is entered through front panel keys. Up to 20 individual calibration factors for up to 8 power sensors can be stored in non-volatile memory.
MEASUREMENT TIME	Diode sensors, typically 0.2 to 0.5 s except 2-6 s below -40 dBm. Thermocouple sensors, typically 0.5 to 6 s for increasing levels, 0.5 to 14 s for decreasing levels.
RECORDER OUTPUT	See Table 1-3.
Watt Mode	10 volts full-scale, proportional to indicated power over each range.
dB Mode	8 volts equivalent to 0 dBm for all sensors with a sensitivity of 1 volt per 10 dB change over the entire range.
DISPLAY	4-digit LED, 3-1/2 digit display of power, 4-digit display of dB with 0.01 dB resolution. Auxiliary analog display, uncalibrated, proportional to recorder output.
dB LIMITS	Entered through front panel in dB only, operable in both dB and power modes.
ANNUNCIATORS	LED display of mW, μ W, nW, dBm, or relative dB (dBr); LED indication of use of channel 1 (CH1), channel 2 (CH2, option -03), and channel 3 (CH 3 = CH1 - CH2 in dB); out of dB limits; and condition of GPIB activity (LSN, ATN, REM, AND TALK, option -01).
POWER CONSUMPTION	24 VA; 100, 120, 220, and 240 volts, 50 to 400 Hz.
WEIGHT	4.54 kg (10 lbs.) approximately.
DIMENSIONS	14.9 cm high \times 21.1 wide \times 34.9 deep (5.85 in. \times 8.3 \times 13.75).
ACCESSORIES FURNISHED	5 foot power sensor cable, Model 41-2A, for each sensor ordered.
ACCESSORIES REQUIRED	One or more of the power sensors: Refer to the Sensor Characteristics.

TABLE I-1. PERFORMANCE SPECIFICATIONS (Cont.)

Parameter	Specifications
<p>OTHER ACCESSORIES AVAILABLE</p> <p>Part No. 950000</p> <p>Part No. 950001</p> <p>Part No. 950002</p> <p>Part No. 950037</p> <p>Part No. 950038</p>	<p>Rack mounts one Model 4200, placed either right or left on 19-inch spacing</p> <p>Rack mounts two instruments, side-by-side</p> <p>Rack mounts one Model 4200 with older Boonton half-rack units, right or left</p> <p>Rack mounts two instruments, side-by-side, with full extension and locking chassis slides</p> <p>Rack mounts one Model 4200, placed either right or left of an accessory storage tray. Provision for front connection to dual-channel rear inputs. Full extension locking slides</p>
<p>OPTIONS</p>	<p>-01A and -01B Remote Operation to IEEE Bus Standard: All front panel controls except line switch and power reference switch. In addition individual power and dB ranges may be selected and selectively zeroed. Listen/talk address set by rear-panel bit switch.</p>
<p>The 4200 implements these subsets of the GPIB function</p>	
<p>SH1 Source Handshake, complete capability</p> <p>AH1 Acceptor Handshake, complete capability</p> <p>T6 Basic Talker, Serial Poll, Unaddress if MLA, No Talker Only capability</p> <p>TE0 No Extended Talker capability</p> <p>L4 Basic Listener, Unaddress if MTA, No Listener Only capability</p>	<p>LE0 No Extended Listener capability</p> <p>SR1 Service Request capability</p> <p>RL2 Remote-Local capability. No Local Lockout</p> <p>PP0 No Parallel Poll capability</p> <p>DC0 No Device Clear capability</p> <p>DT1 Device Trigger capability</p> <p>C0 No Controller capability</p>
<p style="text-align: center;">Note</p> <p style="text-align: center;">MLA = My Listen Address MTA = My Talk Address</p>	
<p>In addition to the talk and listen commands, the 4200 responds to the following: GTL, Go to local; GET, Group Trigger; UNL, Unlisten; UNT, Untalk; IFC, Interface Clear; REN, Remote Enable.</p>	
<p>Output Data Format:</p> <p>abcdEsd, S, R (cr) (lf)</p> <p>ab = Mode: power, dBm, dBr d = Data digit d = Data digit c = Channel number E = Exponent marker S = Status code s = Sign s = Sign R = Range code</p>	
<p>Output Data Speed:</p> <p>Free run access time is 55 ms, or 18 readings per second.</p>	
<p>-03 Input Channel 2: Allows display of either Channel 1 or Channel 2, or Channel 3 which is Channel 1 minus Channel 2, expressed in dB. Requires use of two power sensors. Precludes use of option -02.</p> <p>Channel 1 operates independently of Channel 2. Measurement parameters are entered and stored separately for each channel.</p>	

TABLE 1-1. PERFORMANCE SPECIFICATIONS (Cont.)

In Channel 3 operation, GHz entry applies the appropriate calibration factors for that frequency separately to Channel 1 and Channel 2. Other measurement parameter entries made in the Channel 3 mode do not respond and those previously made for Channel 1 and Channel 2 remain active.

The recorder output is driven by Channel 1 or Channel 2 as selected. In Channel 3 operation the recorder output reverts to Channel 1.

- 04 Rear Input: Duplicates front panel Channel 1 input connector.
- 06 Internal TMA (MATE). Requires -01B Option.
- S/17 Two Inputs-On Front Panel. Requires -03 Option.

TABLE 1-2. SENSOR CHARACTERISTICS

Model (Impedance) (RF Connector)	Freq. Range	PWR range (Watts) (dBm)	Overload Rating (Watts) (dBm)	Max. SWR		Drift and Noise Lowest Range		
				Frequency	SWR	Drift (typical) 1 Hr	Noise (typical) RMS	2 σ
DIODE SENSORS								
51011 (4B) 50 Ω N(M)	100 kHz to 12.4 GHz	1 nW to 10 mW -60 to +10 dBm	300 mW +25 dBm	100 kHz to 2 GHz 2 GHz to 4 GHz 4 GHz to 11 GHz 11 GHz to 12.4 GHz	1.12 1.2 1.4 1.6	150 pW	65 pW	130 pW
51012 (4C) 75 Ω N(M)	100 kHz to 1 GHz	1 nW to 10 mW -60 to +10 dBm	300 mW +25 dBm	100 kHz to 1 GHz	1.18	150 pW	65 pW	130 pW
51013 (4E) 50 Ω N(M)	100 kHz to 18 GHz	1 nW to 10 mW -60 to +10 dBm	300 mW +25 dBm	100 kHz to 4 GHz 4 GHz to 10 GHz 10 GHz to 18 GHz	1.3 1.5 1.7 *	150 pW	65 pW	130 pW
51051 (4G) 50 Ω APC 3.5 (M)	1 MHz to 26.5 GHz	1 nW to 10 mW -60 to +10 dBm	300 mW +25 dBm	1 MHz to 12.4 GHz 12.8 GHz to 18 GHz 18 GHz to 26.5 GHz	1.28 1.37 1.92	100 pW	30 pW	60 pW
51015 (5E) 50 Ω N(M)	100 kHz to 18 GHz	10 nW to 100 mW -50 to +20 dBm	2 W +33 dBm	100 kHz to 1 GHz 1 GHz to 2 GHz 2 GHz to 4 GHz 4 GHz to 12.4 GHz 12.4 GHz to 18 GHz	1.07 1.10 1.12 1.18 1.28	1.5 nW	0.65 nW	1.3 nW
51033 (6E) 50 Ω N(M)	100 kHz to 18 GHz	100 nW to 1 W -40 to +30 dBm	2 W +33 dBm	100 kHz to 1 GHz 1 GHz to 2 GHz 2 GHz to 4 GHz 4 GHz to 12.4 GHz 12.4 GHz to 18 GHz	1.07 1.10 1.12 1.18 1.28	15 nW	6.5 nW	13 nW
THERMOCOUPLE SENSORS								
51016 (7E) 50 Ω N(M)	10 MHz to 18 GHz	1 μ W to 10 mW -30 to +10 dBm	30 mW +15 dBm	10 MHz to 15 MHz 15 MHz to 10 GHz 10 GHz to 18 GHz	1.5 1.35 1.6	450 nW	150 nW	300 nW
* Thermocouple Pulse Characteristics at 25°C. Maximum pulse energy = 5 W- μ sec. Maximum pulse power = 1 W Maximum pulse duration at maximum pulse power = 5 μ sec.								
51017 (8E) 50 Ω N(M)	10 MHz to 18 GHz	10 μ W to 100 mW -20 to +20 dBm	200 mW +23 dBm	10 MHz to 15 MHz 15 MHz to 10 GHz 10 GHz to 18 GHz	1.5 1.35 1.6	4.5 μ W	1.5 μ W	3 μ W
* Thermocouple Pulse Characteristics at 25°C. Maximum pulse energy = 30 W- μ sec. Maximum pulse power = 15 W Maximum pulse duration at maximum pulse power = 2 μ sec.								
WAVEGUIDE SENSORS								
50135 (4K) WR-42 UG-595/U	18 GHz to 26.5 GHz	10 nW to 10 mW -50 to +10 dBm	100 mW +20 dBm	18 GHz to 26.5 GHz	1.3	200 pW	60 pW	120 pW
51972-WRD WRD180C24	18 GHz to 40 GHz	10 nW to 10 mW -50 to +10 dBm	100 mW +20 dBm	18 GHz to 40 GHz	1.3	200 pW	60 pW	120 pW
51038 (4Ka) WR-28 UG-599/U	28.5 GHz to 40 GHz	10 nW to 10 mW -50 to +10 dBm	100 mW +20 dBm	26.5 GHz to 40 GHz	1.3	60 pW	15 pW	30 pW
51037 (4Q) WR-22 UG-383/U	33 GHz to 50 GHz	10 nW to 10 mW -50 to +10 dBm	100 mW +20 dBm	33 GHz to 50 GHz	1.3	60 pW	15 pW	30 pW
51045 (4U) WR-19 UG-383/U	40 GHz to 60 GHz	10 nW to 10 mW -50 to +10 dBm	100 mW +20 dBm	40 GHz to 60 GHz	1.3	60 pW	15 pW	30 pW
51046 (4V) WR-15 UG-385/U	50 GHz to 75 GHz	10 nW to 10 mW -50 to +10 dBm	100 mW +20 dBm	50 GHz to 75 GHz	1.3	60 pW	15 pW	30 pW
51047 (4W) WR-10 UG-387/U	75 GHz to 110 GHz	32 nW to 10 mW -45 to +10 dBm	100 mW +20 dBm	75 GHz to 110 GHz	1.3	60 pW	15 pW	30 pW

NOTES: * Will withstand short periods of overload, extended overload operation may result in permanent change in characteristics or burnout.
Power linearity uncertainty: (worst case) 4B, 4C, 4E (003 x 1) dB per dB above +4 dBm; (above +14 dBm for the 5E and above +24 dBm for the 6E), where f is in GHz. Other sensors: negligible.

Table 1-3A. Model 4200 and DIODE SENSORS: Measurement Speed through the IEEE Bus

Starting Level, dBm			10-dB Power Step		20-dB Power Step		30-dB Power Step		50-dB Power Step	
-4E Sensor	-5E Sensor	-6E Sensor	Increasing	Decreasing	Increasing	Decreasing	Increasing	Decreasing	Increasing	Decreasing
-60	-50	-40	0.60 s	N.A.	0.65 s	N.A.	0.45 s	N.A.	0.50 s	N.A.
-50	-40	-30	0.60 s	5.4 s	0.40 s	N.A.	0.35 s	N.A.	0.50 s	N.A.
-40	-30	-20	0.40 s	1.0 s	0.35 s	5.4 s	0.40 s	N.A.	0.35 s	N.A.
-30	-20	-10	0.35 s	0.50 s	0.35 s	1.0 s	0.40 s	5.4 s	N.A.	N.A.
-20	-10	0	0.35 s	0.30 s	0.35 s	0.55 s	0.30 s	1.0 s	N.A.	N.A.
-10	0	+10	0.20 s	0.25 s	0.15 s	0.25 s	N.A.	0.70 s	N.A.	6.0 s
0	+10	+20	0.15 s	0.35 s	N.A.	0.35 s	N.A.	0.50 s	N.A.	1.7 s
+10	+20	+30	N.A.	0.35 s	N.A.	0.35 s	N.A.	0.60 s	N.A.	1.0 s

Table 1-3B. Model 4200 and THERMAL (true RMS) SENSORS: Measurement Speed through the IEEE Bus

Starting Level dBm		10-dB Power Step		20-dB Power Step		30-dB Power Step		40-dB Power Step	
-7 Sensor	-8E Sensor	Increasing	Decreasing	Increasing	Decreasing	Increasing	Decreasing	Increasing	Decreasing
-30	-20	6.0 s	N.A.	1.0 s	N.A.	0.75 s	N.A.	0.35 s	N.A.
-20	-10	1.0 s	4.0 s	0.75 s	N.A.	0.35 s	N.A.	N.A.	N.A.
-10	0	0.75 s	1.6 s	0.35 s	6.1 s	N.A.	N.A.	N.A.	N.A.
0	+10	0.25 s	1.5 s	N.A.	2.7 s	N.A.	9.0 s	N.A.	N.A.
+10	+20	N.A.	0.50 s	N.A.	4.0 s	N.A.	13.4 s	N.A.	14.0 s

- NOTES:
1. "Measurement Speed" is the time required to make measurements within 0.1 dB of final value on the *ending* range, using an HP-85 controller. The free-run access time is 55 ms (18 measurements per second).
 2. These are typical speeds (in seconds), using the Display-Hold ("Q" command) measurement mode.
 3. With dual-channel operation (i.e.: with Option -03 installed), the measurement rate is two sets of readings per second.

TABLE 1-3. MAXIMUM RESPONSE CHART FOR SERIES 4200-A SENSOR.

Table 1-3C. Model 4200 and DIODE SENSORS: Measurement Speed through the IEEE Bus

Starting Level, dBm	10-dB Power Step		20-dB Power Step		30-dB Power Step		50-dB Power Step	
	Increasing	Decreasing	Increasing	Decreasing	Increasing	Decreasing	Increasing	Decreasing
4K, 4Ka, 4Q, 4U, 4V, 4W, WRD180 Sensors								
-50	0.60 s	N.A.	0.65 s	N.A.	0.45 s	N.A.	0.50 s	N.A.
-40	0.60 s	1.0 s	0.40 s	N.A.	0.35 s	N.A.	0.50 s	N.A.
-30	0.40 s	0.5 s	0.35 s	1.0 s	0.40 s	N.A.	N.A.	N.A.
-20	0.35 s	0.35 s	0.35 s	0.55 s	0.40 s	1.0 s	N.A.	N.A.
-10	0.35 s	0.35 s	0.35 s	0.35 s	N.A.	0.55 s	N.A.	N.A.
0	0.20 s	0.25 s	N.A.	0.25 s	N.A.	0.35 s	N.A.	1.7 s
+10	N.A.	0.35 s	N.A.	0.35 s	N.A.	0.35 s	N.A.	1.0 s

- NOTES:
1. "Measurement Speed" is the time required to make measurements within 0.1 dB of final value on the *ending* range, using an HP-85 controller. The free-run access time is 55 ms (18 measurements per second).
 2. These are typical speeds (in seconds), using the Display-Hold ("Q" command) measurement mode.
 3. With dual-channel operation (i.e.: with Option -03 installed), the measurement rate is two sets of readings per second.

TABLE 1-3. MAXIMUM RESPONSE CHART 2 FOR INSTRUMENT AND 4240 SENSOR (Cont.)

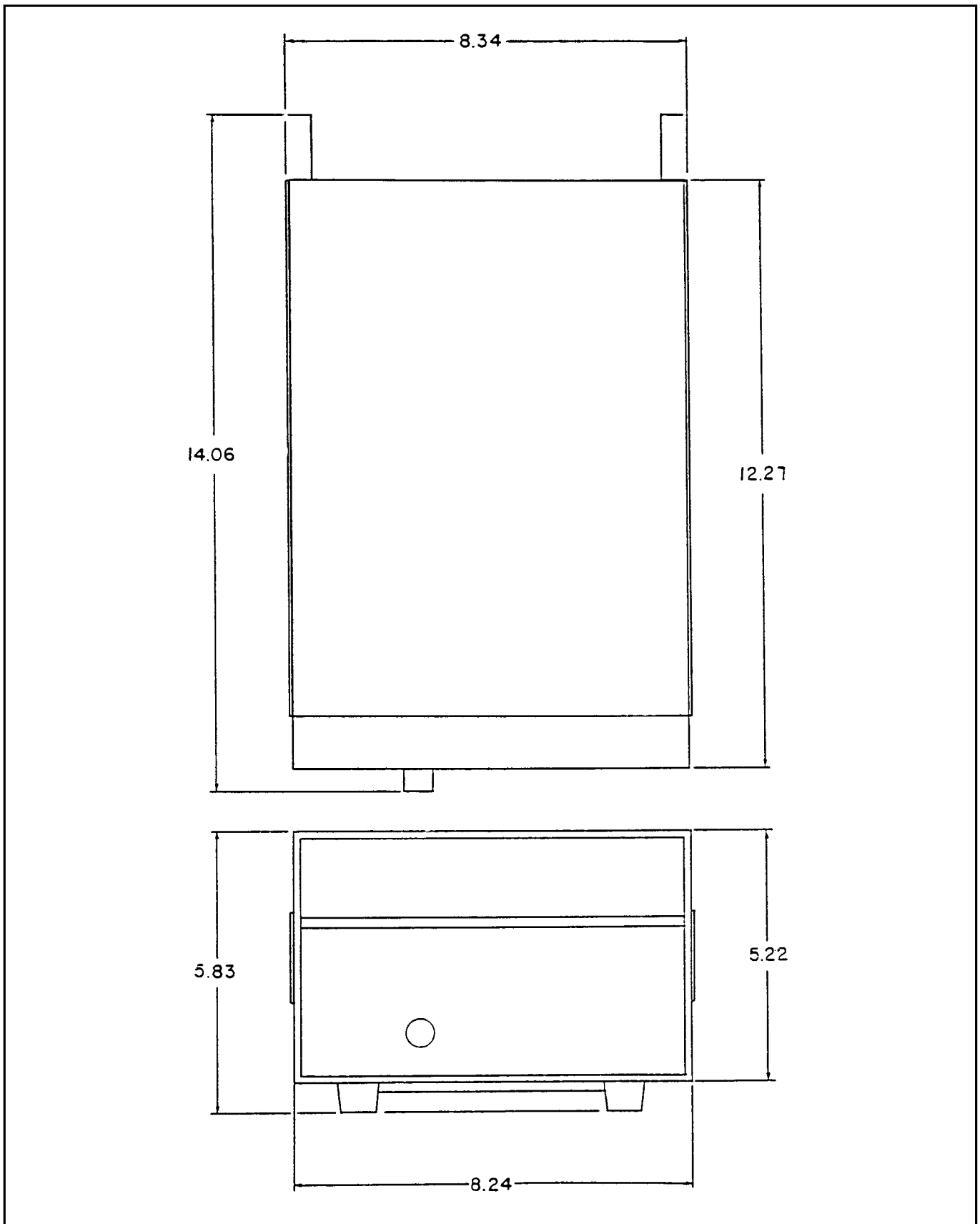

Figure I-2 Outline Dimensions

SECTION II INSTALLATION

2-1. INTRODUCTION.

2-2. This section contains instructions for the installation of the Model 4200 RF Microwattmeter.

2-3. INSTALLATION.

2-4. **Unpacking.** The instrument is shipped complete with sensors (if ordered), and is ready for use upon receipt. Packaging details are shown in Figure 2-1. Unpack the instrument carefully, and inspect it for any signs of shipping damage. Should any damage be noted, notify the carrier and the factory immediately.

NOTE

Save the packing material and container for possible use in reshipment of the instrument.

2-5. **Mounting.** For bench use, choose a clean, sturdy, uncluttered surface. See Figure 1-4 for space requirements. For rack mounting, an accessory package, part number 950000, is available to mount one instrument, and another package, part number 950001, is available to mount two instruments side-by-side.

2-6. **Power Requirements.** The instrument has a tapped power transformer which permits operation from 100, 120, 220, or 240 volt $\pm 10\%$, 50 to 400 Hz, single phase ac power sources. Power consumption is approximately 24 volt-amperes at 60 Hz.

2-7. **Cable Connections.** Interconnecting cable connections required depend upon the options installed and the system applications of the instrument. A line cord and sensor cable are supplied with the instrument. Any other cables required must be supplied by the user. Cable connections that may be required are as follows:

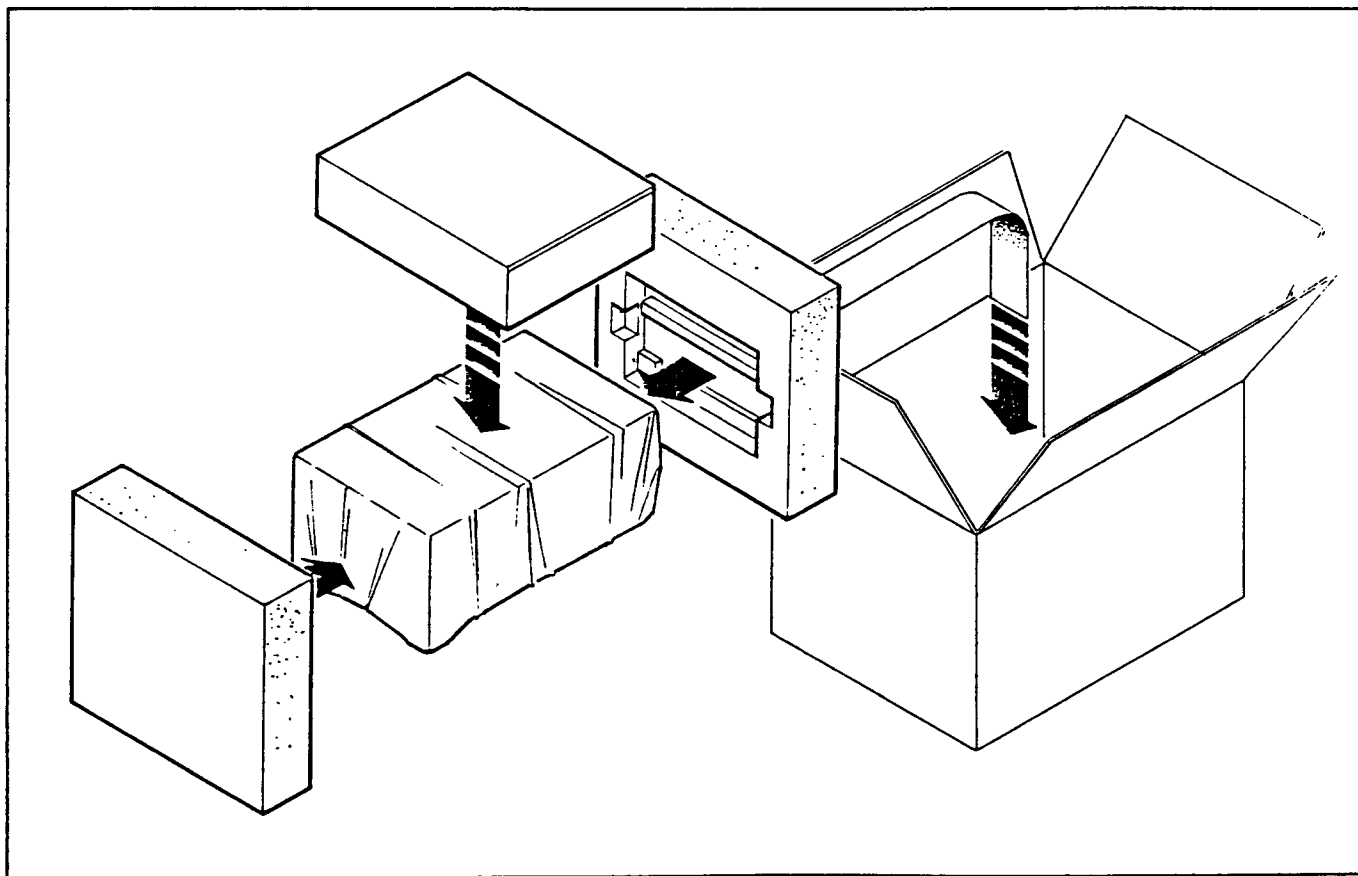

Figure 2-1 Packaging Diagram

**Section II
Installation**

a. **Sensors.** The sensor cable supplied with the basic instrument connects directly to the front-panel SENSOR connector, and the sensor that is to be used for power measurements connects directly to the other end of the sensor cable. Although the sensors are insulated against extreme temperature variations, it is advisable to locate the sensor away from heat sources when using the most sensitive ranges of the instrument. If the instrument is to be used to measure the output of equipment that generates heat significantly above the ambient temperature, a short length of coaxial cable or solid line having the same characteristic impedance as the sensor may be used between the sensor and the equipment undergoing test to allow heat to dissipate before reaching the sensor. If such a cable is used, the length must be kept as short as possible for operation at the high end of the frequency range; cable losses and an increase in SWR will tend to degrade measurement accuracy.

NOTE

The front-panel SENSOR connector is the input connector for channel 1 measurements. If the instrument is equipped with option -03, a sensor may be connected to the rear-panel connector marked SENSOR; the same conditions apply to this sensor connection. The rear-panel connector is the input connector for channel 2-measurements.

* b. **Recorder Output.** Recorder connector J20 (type BNC) on the rear panel provides an analog dc voltage for application to a remote recorder. The output resistance is approximately 9000 ohms, delivering 1 milliampere into a 1000 ohm load for full scale input in the power mode. The analog dc voltage is proportional to the following:

(1.) In the power mode, it is proportional to displayed power, with 10 volts for full scale each range, either channel.

(2.) In the dB mode, it is proportional to displayed dBm with the relationship shown following:

Recorder Output			
	Sensors Series		
	4/7/K/Ka Q/U/V/W/ WRD180	5/8	6
dBm	Volts		
+30	-	-	9
+20	-	9	8
+10	9	8	7
0	8	7	6
-10	7	6	5
-20	6	5	4
-30	5	4	3
-40	4	3	2
-50	3	2	-
-60	2	-	-

(3.) In the channel 3 mode (option), it is similar to the dB mode, but for the channel 1 level only.

c. **Status Output.** Rear-panel connector P3 provides signal outputs for input disconnect during zeroing operations and high and low dB limit signals during dB measurements. The dB limits always test against the displayed value for operation. With the calibration factor and dB reference level equal to zero, the dB limits entered prevail. With a dB reference level other than zero the displayed value is checked against the limits chosen. In the channel 3 mode (option), the first limit exceeded, whether channel 1 or channel 2, activates the limit status Pin connections are as follows:

Connector Pin	Signal
1	Common
2	Not used
3	Logic high indicates zeroing operation
4	Logic low within dB limits; logic high above high dB limit
5	Logic low within dB limits; logic high below low dB limit

SECTION III OPERATION

3-1. INTRODUCTION.

3-2. This section contains the operating instructions for the Model 4200 RF Microwattmeter.

3-3. OPERATING CONTROLS, INDICATORS, AND CONNECTORS.

3-4. The controls, indicators, and connectors used during the operation of the instrument are listed in Table 3-1 and shown in Figures 3-1 and 3-2.

3-5. SENSOR CALIBRATION DATA.

3-6. Calibration corrections for sensors ordered with the instrument are written into microprocessor storage at the factory before shipment of the instrument and sensor. A copy of this information is stored under the right side cover. When the CAL FACTOR GHz function of the instrument is used during measurement, the microprocessor reads and interpolates the stored data on the basis of the specified measurement frequency, and corrects all measurement values accordingly. The microprocessor memory has storage capacity for calibration data for up to eight sensors. Calibration corrections vary for different sensors; therefore, if sensors are to be substituted or added in the field, calibration data for these sensors must be written into memory in the field in order for the CAL FACTOR GHz function to be accurate. Refer to paragraph 5-37 for calibration data entry procedures.

3-7. POWER APPLICATION.

3-8. The basic instrument is designed for operation from a 100, 120, 220, or 240 volt, 50 to 400 Hz, single phase, ac power source. To apply ac power, proceed as follows:

a. Determine the line voltage at the ac power output receptacle.

b. Set the two slide switches on the rear panel to conform to the available ac line voltage.

c. Check the rating of the fuse in the rear-panel fuseholder. For 100 or 120 volt operation, the fuse should be a 0.3 ampere, MDL Slo-Blo type; for 220 or 240 volt operation, it should be a 0.2 ampere, MDL Slo-Blo type. If the rating of the fuse is incorrect, install a fuse of the required rating in the fuseholder.

WARNING

The instrument is designed to operate from a 3-terminal (one ground) ac power receptacle.

If only a 2-terminal ac power receptacle is available, use a 3-prong to 2-prong adapter. Connect the ground wire of the adapter to the power receptacle ground to eliminate a potential shock hazard to the operator.

d. Connect the power cord between the ac power connector on the rear panel of the instrument and the ac power receptacle (with adaptor, if necessary).

3.9 PRELIMINARY CHECKOUT

NOTE

The following checkout procedure is intended merely to demonstrate that the major circuits of the instrument are operating before the instrument is placed for service. For a detailed check of the instrument against performance specifications, refer to paragraph 3-34.

3-10. To perform the preliminary checkout, proceed as follows:

a. Set the LINE switch to the ON position.

b. Check operation of the LED display and the numerical keys by pressing the following keys in the

Section III
Operation

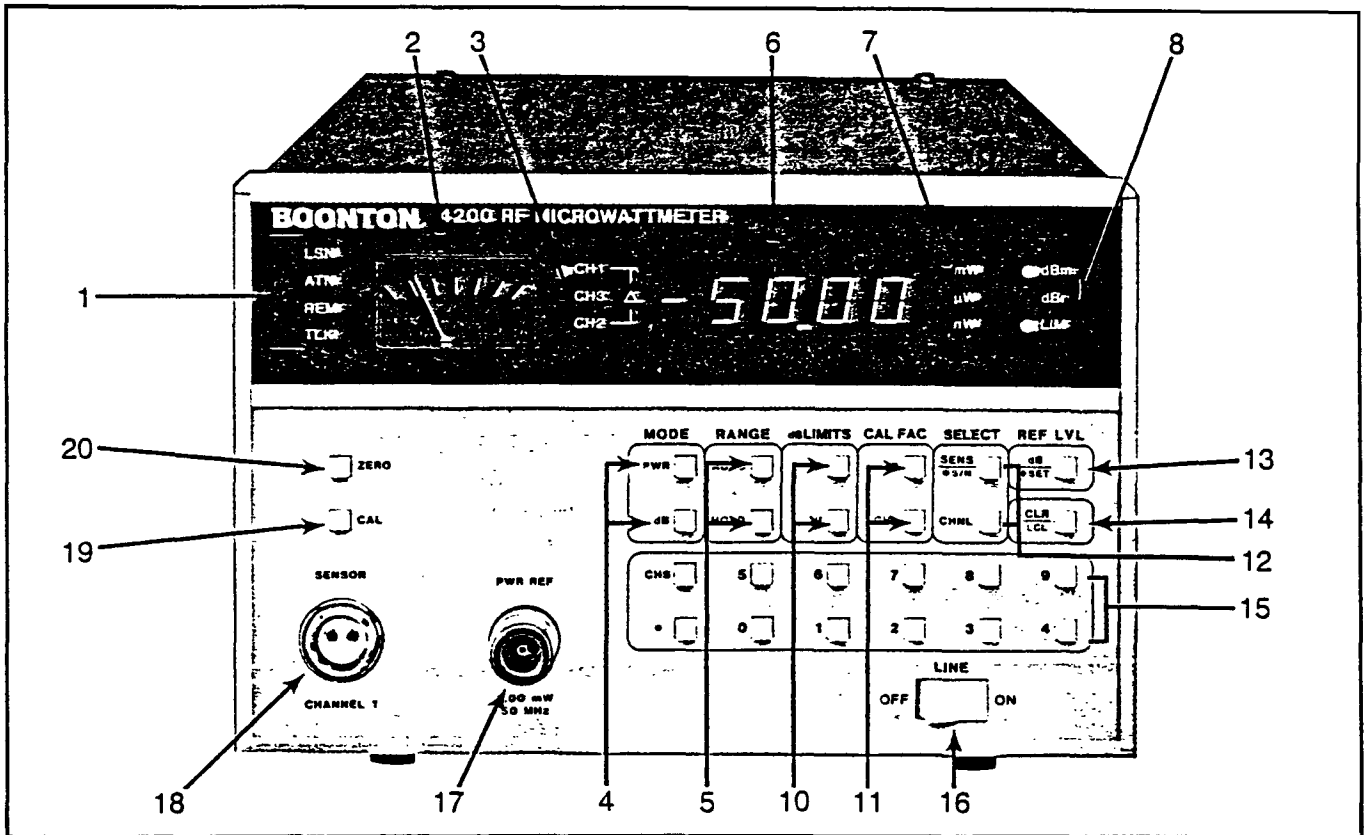

Figure 3-1 Front View of Instrument

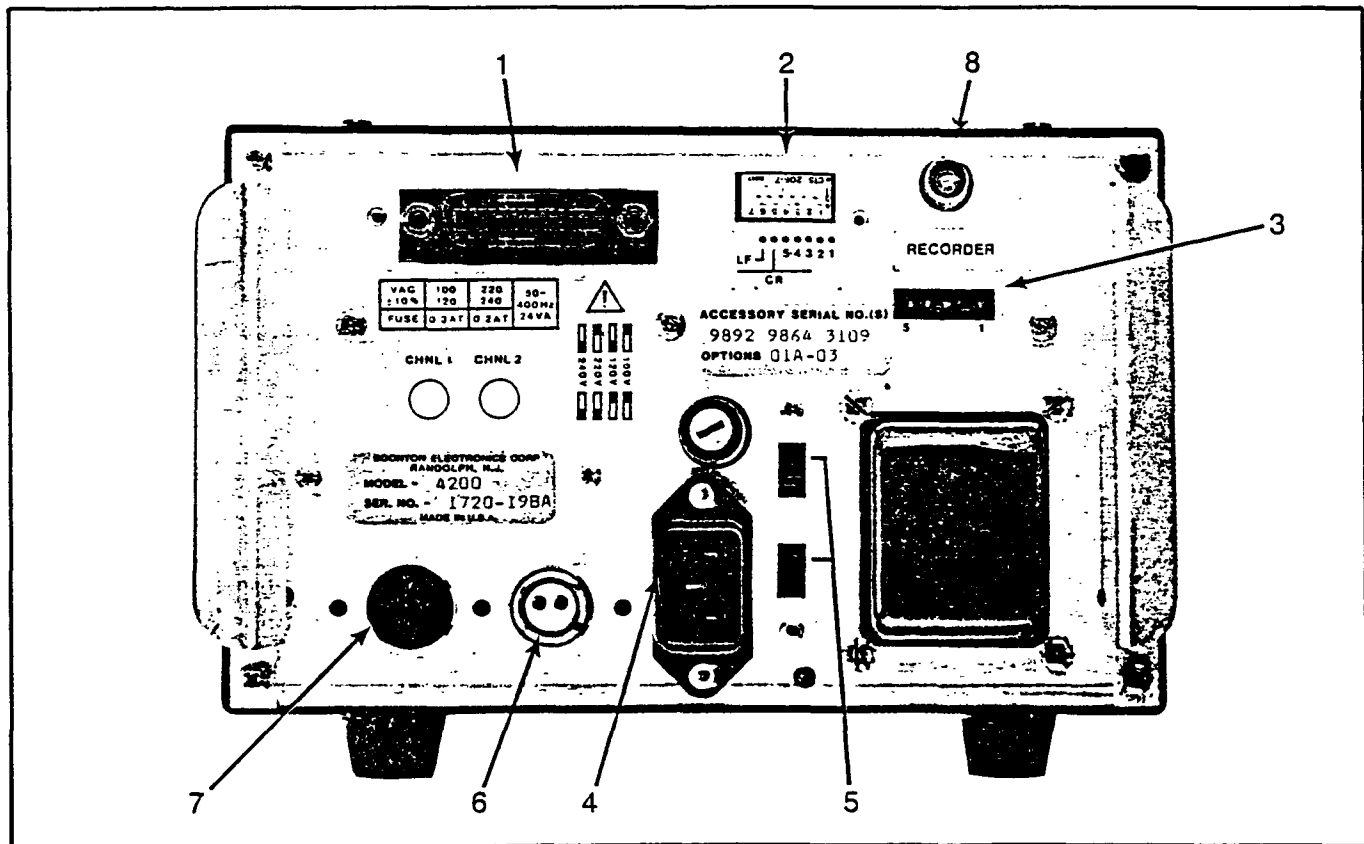

Figure 3-2 Rear View of Instrument

**TABLE 3-1. OPERATING CONTROLS,
INDICATORS, AND CONNECTORS**

Control, Indicator or Connector	Figure and Index No.	Function	Control, Indicator, or Connector	Figure and Index No.	Function
LSN, ATN, REM, and TLK annunciators	3-1, 1	Indicates operation of IEEE-488 bus interface (option -01).	SELECT keys	3-1, 12	Provides means for entering and recalling channel and sensor serial numbers.
Meter	3-1, 2	Indicates power and dB levels for peaking and nulling operation.	CHNL key		
CH1, CH2, and CH3 annunciators	3-1, 3	Indicates channel in use.	$\frac{\text{SENS}}{\cdot\text{S/N}}$ key		Provides means to set the dB reference level.
MODE keys	3-1, 4	Selects LED display indication mode (POWER or dB).	REF LEL	3-1, 13	
RANGE keys	3-1, 5	Selects ranging mode (AUTO or HOLD).	$\frac{\text{dB}}{\cdot\text{SET}}$ key		Provides means for clearing incorrect digit(s) entry, clearing dB calibration factor and dB reference level to zero, and returns keyboard control from IEEE-488 bus control.
LED display	3-1, 6	Four digit LED display with minus sign and decimal points: provides numerical indication of measured power or dBm, and of data entered or recalled through keyboard, or error messages,	CLR	3-1, 14	
mW, μW , and nW annunciators	3-1, 7	Indicates units of power when instrument is operating in power mode.	LCL key		Provides means for entering signed numerical data.
dBm and dBr annunciators	3-1, 8	Indicates dB mode in use when instrument is operating in dB mode.	Numerical, decimal point, and CHS keys	3-1, 15	
LIM annunciator	3-1, 9	Indicates when power level in dB is outside selected dB limits.	LINE switch	3-1, 16	Provides means for turning AC line power on and off.
dB LIMITS keys	3-1, 10	Provides means for entering and recalling dB limits (LO and HI).	POWER REF connector	3-1, 17	Supplies 1 mW level at 50 MHz to 50 ohm load when POWER REF ON switch is set to ON position.
CAL FAC keys	3-1, 11	Provides means for entering and recalling calibration factors in terms of dB or frequency.	SENSOR connector	3-1, 18	Provides means for connecting sensor to channel 1 input.
			CAL key	3-1, 19	Provides means for calibrating instrument when sensor is connected to 1 mW source.
			ZERO key	3-1, 20	Provides means for generating and storing zero corrections for all ranges with zero input to sensor.

TABLE 3-1. OPERATING CONTROLS, INDICATORS, AND CONNECTORS (Cont.)

Control, Indicator or Connector	Figure and Index No.	Function	Control, Indicator, or Connector	Figure and Index No.	Function
J1 connector	3-2, 1	Connector for IEEE-488 bus operation (option -01).	Power connector	3-2, 4	Provides connection for power cord.
S1 switch	3-2, 2	Provides means for selecting instrument address when instrument is equipped with IEEE-488 bus interface option (option -01A) and message terminator.	LINE VOLTAGE selector switch	3-2, 5	Provides means for selecting proper line voltage.
P3 connector	3-2, 3	Provides logic level signals for input disconnect during zeroing operations and high and low dB limit signals during dB measurements.	INPUT connector	3-2, 6	Provides means for connecting sensor to channel 2 input (option 03).
			INPUT connector	3-2, 7	Alternate position for INPUT channel 1 (option 04).
			RECORDER connector	3-2, 8	Provides means for connecting analog DC voltage to remote recorder.

sequence indicated and noting the LED display:

Press	Display
CLR	0000
.	0000.
0	000.0
1	00.01
2	0.012
3	0123
CLR	0000
4	0004
5	0045
6	0456
7	4567
CLR	0000
8	0008
9	0089
CHS	-0089
CLR	0000

c. Enter measurement parameters by pressing the following keys:

1 SELECT CHNL
MODE dB
RANGE AUTO
0 CAL FACTOR dB
0 REF LEVEL dB
90 CHS dB LIMITS LO
90 dB LIMITS HI

d. Connect the sensor cable to the front-panel SENSOR connector, and connect the sensor to the free end of the sensor cable. Note the sensor number indicated on the barrel of the sensor, and enter this number through the numerical keyboard by pressing the numerical key corres-

ponding to the sensor number and then pressing the SELECT SENS keys. (Example: 2 SELECT SENS.)

e. Check to see that the dBm and CH1 annunciator lighted.

f. With zero input to the sensor, press the ZERO the instrument will now begin the zeroing process. instrument display during the zeroing period will be "cccc". Upon completion of zeroing, the display will be "cc03"

g. Connect the sensor to the POWER REF connector. The LED display should indicate approximately 00.00 dBm (assuming that a 50-ohm sensor is used). If it does press the CAL key.

h. Key in .2 CAL FACTOR dB through the keyboard. The LED display should change to approximately 00.20 dBm.

i. Key in 0 CAL FACTOR dB through the keyboard. The LED display should return to approximately 00.00 dBm.

j. Key in 1 CHS REF LEVEL dB through the keyboard. The LED display should indicate approximately 01.00 dB.

k. Key in 1 REF LEVEL dB through the keyboard. The LED display should indicate approximately -01.00 dB.

l. Key in 5 dB LIMITS HI through the keyboard. The LIM annunciator should be off.

m. Key in 5 CHS dB LIMITS LO through the keyboard. The LIM annunciator should remain off.

n. Key in .5 dB LIMITS HI through the keyboard. The LIM annunciator should remain off.

o. Key in .5 CHS dB LIMITS LO through the keyboard. The LIM annunciator should light.

p. Key in 0 REF LEVEL dB through the keyboard. The LED display should indicate 00.00, the LIM annunciator should be off and the dBm annunciator should be lighted.

q. Press the MODE PWR key. The LED display should indicate approximately 1.000 mW.

r. Disconnect the sensor from the POWER REF connector.

3-11. OPERATING INSTRUCTIONS.

3-12. Measurement Parameters.

a. **General.** Measurement parameters are entered into the microprocessor through the front-panel keyboard. In order to eliminate the need for repeated reprogramming, parameters entered through the keyboard are stored in non-volatile memory, and the stored parameters are unaffected by instrument turn-off and turn-on. It is important to remember that the last used parameters are stored in the instrument because these stored parameters could cause what may appear to be erroneous indications when subsequent measurements are made. For example: if the instrument had been programmed for operation with sensor 2 and sensor 1 is used instead, the LED display may be inaccurate if a GHz calibration factor is entered because the sensor 2 calibration factors will be used by the microprocessor instead of the sensor 1 calibration factors. If there is any question about stored measurement values, the last entered values can be recalled for display as described in subparagraph b below. Measurement parameters may be changed at any time.

NOTE:

When the instrument is in the store or recall mode, the LED display and the annunciators blink on and off. This feature is intended to alert the operator to the fact that the displayed value *is not* a measured value; it is a value that has been recalled from the instrument memory or that is to be entered into memory.

3-13. Use of Numerical Keys. The numerical keys are used to enter numerical values for dB LIMITS, CAL FACTOR, SELECT, and REF LEVEL dB functions. Whenever any numerical key is pressed, the microprocessor interrupts the measurement operation to accept new data. Numerical values are keyed in normal sequence, and keyed-in values enter the LED display from right to left. Up to four digits, plus decimal point and minus sign can be entered; entries exceeding four digits are ignored. Pressing the decimal point key places a decimal point after the right-most digit in the LED display. Pressing the CHS key changes the sign of

the entry in the LED display; that is, plus becomes minus, or minus becomes plus. (The plus sign is not displayed.) If an error is made during entry of numerical values, press the CLR key and repeat the data entry process. When the LED display shows the desired numerical value, pressing the applicable dB LIMITS, CAL FACTOR, SELECT, or REF LEVEL dB key will cause the microprocessor to store the keyed in parameter and return automatically to the measurement cycle. Recall of the last entered values is accomplished by depressing the dB LIMITS HI, dB LIMITS LO, CAL FACTOR dB, CAL FACTOR GHz, SELECT CHNL, SELECT SENS, or REF LEVEL dB keys, as applicable. The value stored for the selected parameter is displayed on the LED display. When a recall is performed, the instrument remains in the recall state until either a MODE key or a RANGE key is depressed: the instrument then returns to the operating state.

3-14. SELECT Function. The SELECT keys are used by the operator to specify the number of the sensor to be used for measurements, and the measurement channel.

IMPORTANT NOTE:

For normal operation, the CHANNEL and sensor must be selected before any operation is performed, however, the CHANNEL must be selected before the sensor is selected.

a. The basic instrument contains only one measurement channel. This measurement channel is designated channel 1, and the front-panel SENSOR connector provides the input to this channel. An option is available for addition of a second measurement channel. When this option is included, the additional channel is designated channel 2, and input power levels are applied to this channel for measurement through a rear-panel connector. To further enhance the usability of the instrument, a channel 3 mode may be exercised. When channel 3 operation is specified, channel 1 and channel 2 levels are measured and compared by the microprocessor, and the difference in relative dB (with the channel 2 level as the reference) is displayed on the LED display. Channel 1 measurements, channel 2 measurements, or the channel 3 function can be selected using the numerical keys and the SELECT CHNL key.

Example: To select the channel 1 input for measurement:

Press	Display
1	0001
SELECT CHNL	

b. Calibration data for up to eight sensors can be stored in the instrument. In order to use the proper calibration data when the CAL FACTOR GHz function is selected, the microprocessor must be advised as to which sensor is being used. The SELECT SENS key is used in conjunction with the numerical keys for this purpose. The sensor number is shown on the barrel of each sensor.

**Section III
Operation**

Example: To specify sensor number two:

Press	Display
2	0002
SELECT SENS	

c. Sensor serial numbers are stored in the non-volatile memory. To recall sensor serial numbers:

Press	Display
• key,	will respond
<u>SENS</u>	with the serial
•S/N key.	number stored in
	memory.

3-15. MODE Selection. The MODE keys enable the operator to select the desired measurement mode. When the MODE PWR key is pressed, measured power levels are displayed in mW, μ W, or nW; the annunciators associated with the LED display indicate the appropriate unit. When the MODE dB key is pressed, measurement values are displayed in terms of dB with respect to an operator-entered dB reference level. If 0 dB had been chosen as the reference level, the displayed numerical values represent dBm, and the dBm annunciator is lighted; selection of any other dB reference level causes lighting of the dB_r annunciator, and displayed measurement values represent dB with respect to the selected reference level. Resolution of the instrument in the dB mode is 0.01 dB.

3-16. RANGE Selection. The RANGE keys enable the operator to select either automatic ranging or a range hold function. The automatic ranging function, which is most effective when measuring unknown or wide varying power levels, is activated by pressing the RANGE AUTO key, and the microprocessor then selects the appropriate measurement range automatically. If input power levels exceed the upper measurement limit of the instrument, an error indication (cc04) appears on the LED display; if input power levels are below the low measurement limit of the instrument, the instrument displays cc03. Ranging time is a function of a number of factors such as absolute level, change in level, analog response time, and direction of change (See Figure 1-2 and 1-3). The range hold function is useful when a series of measurements of approximately the same power level are to be made; selecting this mode eliminates delays due to ranging time. The range hold function is useful only in the PWR mode. When the RANGE HOLD key is pressed, the instrument remains on the measurement range that was active at the time the key was pressed. Input power levels that exceed the upper limit of this range cause an error indication (cc04) on the LED display; input power levels below the low limit of this range result in fewer significant digits in the LED display. If the minimum capability of the instrument is reached, the instrument displays cc03.

3-17. dB LIMITS Selection. The dB LIMITS keys enable the operator to program high and low dB limits into the instrument. Input power levels outside these limits will cause lighting of the LIM annunciator and activation of out-of-limit signals at rear-panel connector P3.

a. Limits are entered by keying in the numerical value in dB, using the numerical keys, and then pressing the dB LIMITS LO or dB LIMITS HI key, as applicable.

Example: To enter a low limit of -31.34 dB:

Press	Display
3	0003
1	0031
.	0031
3	031.3
4	31.34
CHS	-31.34
dB LIMITS LO	

b. The dB limits always test against the value displayed. If the measurement is in dBm (0 REF LEVEL dB), the limit is in dBm. If any value other than 0 dB is chosen for the reference level, the limits operate in dB_r (relative dB), which is the displayed value. If it is desired to have the limits operate on dBm when the REF LEVEL is other than 0 dBm, the value entered as the REF LEVEL should be subtracted algebraically from the desired dBm limits (reverse the sign of the REF LEVEL dB and add algebraically to the desired limit in dBm).

c. The dB limit function is always operative in the instrument. For all practical purposes, it can be cancelled, if desired, by entering a high limit of 90 dB and a low limit of -90 dB.

3-18. CAL FACTOR Selection. The sensors used with the instrument are frequency sensitive; that is, with a constant input power level applied, their output signal level does not remain constant as the measurement frequency is changed. The CAL FACTOR keys provide means for introducing a calibration factor in terms of one or two parameters; either the actual dB calibration factor, or the measurement frequency.

a. A calibration chart is attached to the barrel of each sensor, and the calibration factor in dB for the measurement frequency being used can be computed from this chart. This dB calibration factor can then be entered into the instrument, using the numerical keys and the CAL FACTOR dB key, and the microprocessor will correct all subsequent measurements, both dB and power, automatically in accordance with the dB calibration factor entered.

Example: To enter a dB calibration factor of -0.3 dB:

Press	Display
.	0000.
3	000.3
CHS	-000.3

CAL FACTOR dB

b. Reading and interpolation of the calibration chart can be tedious and subject to error or inaccuracy. The CAL FACTOR GHz function provides a simple, alternative method for calibration data selection. Calibration data for up to eight sensors can be stored in the memory; such calibration data may be entered into storage at the factory or in the field. When the sensor number and the measurement frequency are entered through the keyboard, the microprocessor computes the required correction from the stored data and corrects subsequent dB and power measurements accordingly. The sensor number is entered using the SELECT function described in subparagraph g; the measurement frequency is entered using the numerical keys and the CAL FACTOR GHz key. To recall the last entered frequency for display, press the CAL FACTOR GHz key; to determine the calibration factor value for this frequency, press the CAL FACTOR dB key. Press a MODE key or a RANGE key to return the instrument to the operate mode.

Example: To specify a measurement frequency

Press	Display
3	0003
.	0003.
3	003.3

CAL FACTOR GHz

3-19. REF LEVEL dB Selection. The instrument normally uses 1 mW, 50 ohms as a reference for computing dBm measurement values; the dBm annunciator is lighted during such operation. The REF LEVEL dB key, used in conjunction with the numerical keys, enables the operator to select any other desired dB reference level; subsequent level indications are with respect to the selected reference, and this display mode is indicated by lighting of the dB annunciator.

a. A dB reference level is entered by keying in the desired numerical value in dB, using the numerical keys, and then pressing the REF LEVEL dB key.

Example: To enter a dB reference level of -15.3 dB:

Press	Display	Annunciators	
		dBm	dB
1	0001	Lighted	Off
5	0015	Lighted	Off
.	0015.	Lighted	Off
3	015.3	Lighted	Off
CHS	-015.3	Lighted	Off
REF LEVEL dB		Off	Lighted

b. To return to the dBm measurement display mode, enter a 0 dB reference level, or press the CLR and REF LEVEL dB keys.

Example:

Press	Display	Annunciators	
		dBm	dB
0	0000	Off	Lighted
REF LEVEL dB		Lighted	Off

NOTE:

The maximum display capability of the LED display is ± 99.99 dB. When operating in the dB mode, keep this fact in mind. Avoid choice of dB reference levels that will result in display values that exceed the LED display capacity. Keyboard entries beyond the capability of the instrument produce error indications (cc01 or cc02 for entries too small or too large, respectively).

c. The displayed dBm may also be used as the reference level. This is accomplished by first depressing the decimal point key and then the REF LVL dB key.

The display will indicate 00.00 showing that the previously displayed dBm level has now become the REF LEVEL. This reference may be recalled by pressing the REF LEVEL dB key; it can be cleared by depressing the CLR and then the REF LEVEL dB keys.

Note that this entry method utilizes the *current* dBm level, and would replace any previously entered dB reference level. Note also that this procedure of entering the existing dBm level as the dB reference level is *not* operative in IEEE-488 bus interface operation (Appendix A).

3-20. Entry Limits. Limits for entry of parameter values are as follows:

- CAL FACTOR dB: 3.00 to -3.00
- CAL FACTOR GHz: 0.0 GHz to 999 GHz (sensor dependent) with minimum increment of 0.1 GHz
- REF LEVEL dB: 0 to ± 99.99 , with minimum increment of 0.01 dB
- dB LIMITS LO and dB LIMITS HI: 0 to ± 99.99 , with minimum increment of 0.01 dB.

3-21. Recall of Entered Values. The last entered value for each of the corresponding functions may be recalled for display on the LED display by pressing the following keys:

dB LIMITS LO	SELECT SENS
dB LIMITS HI	SELECT CHNL
CAL FACTOR dB	REF LEVEL dB
CAL FACTOR GHz	

**Section III
Operation**

After any of the above keys are pressed, the instrument remains in the recall mode. To return to the operating mode, press any of the MODE keys or RANGE keys.

NOTE

When the instrument is in the recall mode, the LED display and the annunciators will blink on and off.

3-22. Zeroing the Instrument. For greatest accuracy, especially on the most-sensitive ranges, the instrument must be zeroed. Zeroing is accomplished by depressing the ZERO key with zero power applied to the sensor.

The zeroing period is composed of two parts. When the ZERO key is depressed, a range-dependent "waiting period" occurs first; it is followed by the actual zero acquisition for each range. The purpose of the waiting period is to permit the sensor, and the instrument's analog and digital circuits, to reach a clear (zero) state. The higher the level of the signal prior to zeroing, the longer the waiting period required.

NOTE

When the instrument is first turned on, *two* successive zeroing operations should be performed.

A TTL-compatible signal (true high), marking the beginning of the zeroing operation, is available at Pin 3 of P3 on the rear panel. If this signal is utilized to remove incoming power to the sensor, the waiting period will automatically become range-dependent. If this TTL signal is not utilized, the same results can be achieved by depressing the ZERO key immediately before removing the incoming signal from the power sensor. If the incoming signal is removed *prior* to depressing the ZERO key, the instrument will immediately begin down-ranging—which would result in a shorter waiting period than is desirable. In such an event, a *second* zeroing operation should be used.

CAUTION

If the rear-panel (Pin 3, P3) power-removal signal is not utilized, signal power *must* be removed immediately following depression of the ZERO key. If signal power remains connected to the sensor during the zeroing operation, an erroneous set of zeroes will be generated.

During the warm-up period, and whenever ambient conditions are changing, the instrument should be zeroed frequently if the lowest ranges (i.e. highest-sensitivity ranges) are being used.

The display during the zeroing period will indicate cccc. On completion of zeroing, and if no signal is being applied to

the sensor, the display will indicate cc03. If a signal is being applied, and if the rear-panel (Pin 3, P3) power-disconnect signal is being utilized, the display will indicate the power being supplied to the sensor.

The approximate zeroing times, including the "waiting periods," are listed in Table 3-2.

TABLE 3-2. INSTRUMENT ZEROING TIME

Sensor Series					Zeroing Time (Seconds)
4200-4 dBm	4200-5 dBm	4200-6 dBm	4200-7 dBm	4200-8 dBm	
+10	+20	+30			22
0	+10	+20			20
-10	0	+10			18
-20	-10	0	+10	+20	16
-30	-20	-10	0	+10	14
-40	-30	-20	-10	0	12
-50	-40	-30	-20	-10	10

3-23. Calibrating the Instrument. The instrument incorporates a power reference and automatic calibration facilities for fine sensitivity corrections. Sensitivity corrections are limited to a maximum of approximately $\pm 3.5\%$ from the original, factory set values as a precautionary measure. This feature protects against gross miscalibration which might occur if calibration were attempted with a power level other than that supplied by the power reference applied to the sensor. If computed calibration corrections from the factory set value exceed approximately $\pm 3.5\%$, the instrument rejects the sensitivity correction and reverts to its previous sensitivity. To use the calibration function, proceed as follows:

- a. Program the instrument for power mode, autorange, and the appropriate measurement channel and sensor.
- b. Enter a calibration factor of 0 dB through the keyboard.
- c. Connect the sensor to the POWER REF connector.
- d. Press the CAL key. The LED display should indicate 1.000 mW $\pm 0.1\%$ ($\pm 0.4\%$ for 4200-5 sensors).

NOTE

If the instrument is supplied with a 75-ohm sensor (4200-4C), an adapter (P/N 950006) is also supplied. Use this adapter between the POWER REF connector and the sensor to convert the Type N POWER

REF connector to a 75-ohm Type N. Before calibration, enter a 1.76 dB CAL FACTOR to compensate for the mismatch error that is introduced by the 75-ohm sensor.

3-24. Error Messages. Under certain conditions, the LED display returns error messages as follows:

Display	Condition
cc01	Illegal entry, too low
cc02	Illegal entry, too high
cc03	Signal level out of range (low)
cc04	Signal level out of range (high)
cc05	Zero acquisition out of range-excessive negative offset (hardware malfunction)
cc06	Zero acquisition out of range-excessive positive offset (input too large)
cc07	Signal level out of range, one channel high, one channel low, in channel 3 mode of operation.

3-25. MEASUREMENTS.

3-26. Making Power Measurements. Once the instrument has been programmed, calibrated, and zeroed, it is ready for power level measurements. Merely connect the sensor to the source whose power level is to be measured. The power level will be displayed directly on the LED display.

3-27. Low-Level Measurements. The instrument will provide reliable, reproducible measurements of CW, AM, and FM power levels as low as 1 nW (-60 dBm). It can also be used for pulse measurements but with slightly decreased accuracy (\pm dB). Peak power levels for pulse measurements should not exceed 200 μ W (20 μ W for Series 4200-4 sensors); above this level the sensor enters the region where it operates out of the square-law region, and accuracy at such signal levels is correct for CW and FM only.

3-28. High-Level Measurements. Zeroing of the instrument is not critical when making high-level measurements (10 μ W to 1 W). CW and FM power measurements can be obtained within the specified accuracy up to 1W; accuracy cannot be guaranteed for pulse power measurements with instantaneous (35 μ W for Series 4200-4 sensors) peaks exceeding 350 μ W.

3-29. High-Frequency Measurements. At frequencies above 1 GHz, the appropriate sensor calibration factor must be entered through the keyboard if the specified accuracy of the instrument is to be realized. (Refer to paragraph 3-18).

NOTE

Model 4200-4A, 4200-4B, 4200-4E, 4200-5B, 4200-

5E, 4200-6E, and 4200-7E, 4200-8E, and Waveguide Sensors are calibrated for use with a 50-ohm source; model 4200-4C sensors are calibrated for use with a 75-ohm source. Impedance mismatch results in increased SWR, which affects measurement accuracy. This effect can be reduced by inserting a low-SWR attenuator (SWR less than 1.10) or a low-loss tuner between the source and the sensor.

3-30. Temperature Effects. Specified instrument accuracies apply over an ambient temperature range of 21°C to 25°C. Operation outside this temperature range causes some additional error. Refer to table 1-1 for accuracy versus temperature. Figure 3-3 shows typical temperature characteristics of sensors, and Figure 3-4 shows typical temperature characteristics of the instrument and sensors combined.

NOTE

For best zero stability of the instrument, allow the instrument and sensor to reach a stable temperature.

3-31. SWR Measurements. The high upper-frequency limit and sensitivity of the instrument facilitate SWR measurements with a slotted line. SWR measurements require only comparative, rather than absolute, measurement values; therefore, the instrument may be used up to 20 GHz with a model 4200-4E sensor. The front-panel meter is especially useful for rapid determination of maximum and minimum power points. SWR is determined by measuring the dB difference between a maximum and a minimum voltage point on a slotted line and converting this difference to SWR. An adapter, usually available from the slotted-line manufacturer, is required to couple the sensor to the slotted line. To make slotted-line SWR measurements, proceed as follows:

- Connect the sensor to the sliding carriage, using a suitable adapter.
- Ascertain that the signal source is turned off; then, zero the instrument.
- Turn on the signal source and slide the carriage along the slotted line until a point of maximum indication is located. Adjust the source signal level and the probe setting for the least coupling that yields a -41 dBm reading at the maximum point. (The incident power should be at least 0 dBm.)
- Slide the carriage along the slotted line until a minimum indication is located. Read the level at this point. Subtract the measured level at the minimum point from that at the maximum point, ignoring signs. Convert the resultant Δ dB into SWR, either through use of the SWR conversion chart (Figure 3-5) or by computation. SWR is the antilog, base 10, of Δ db/20.

Section III
Operation

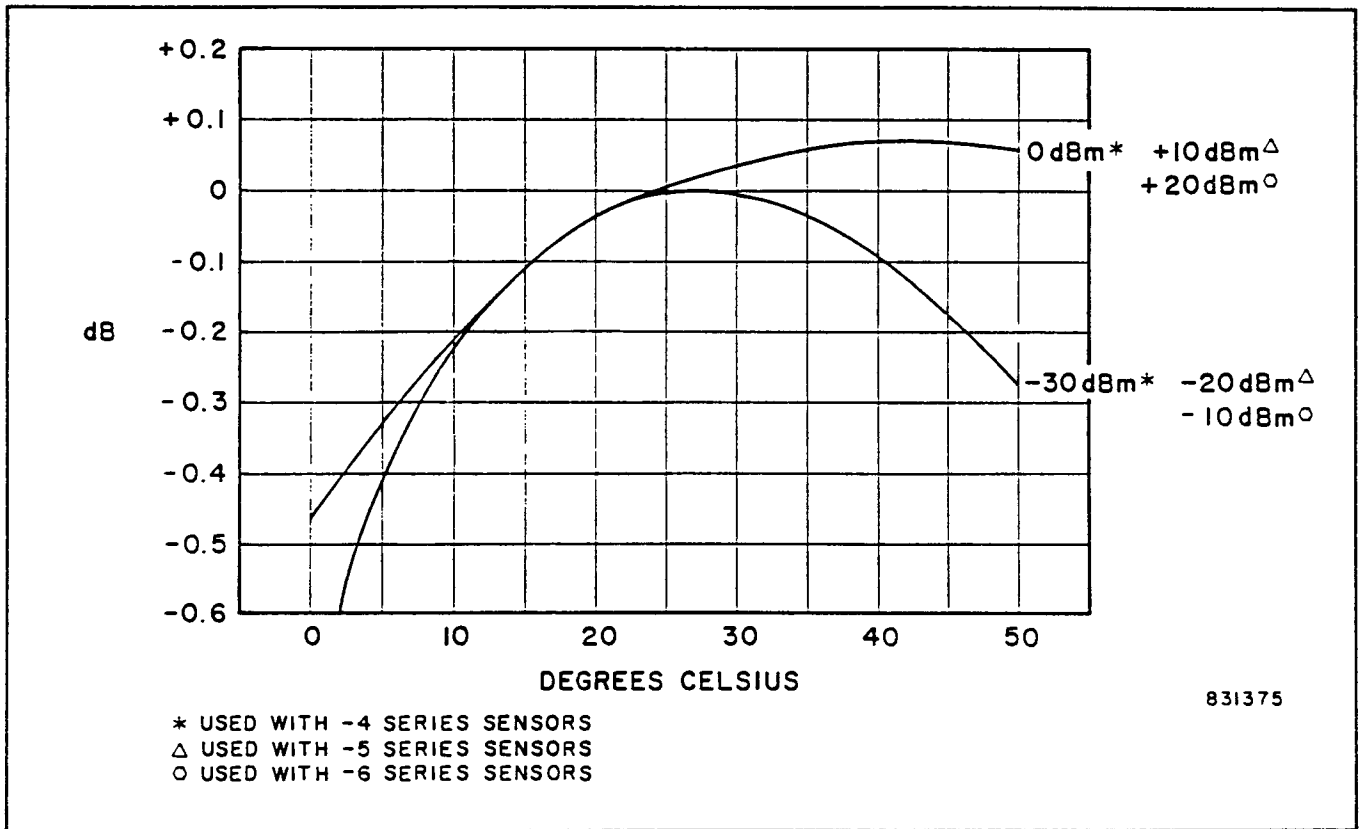

Figure 3-3 Typical Temperature Characteristics of Series 4200 Sensors

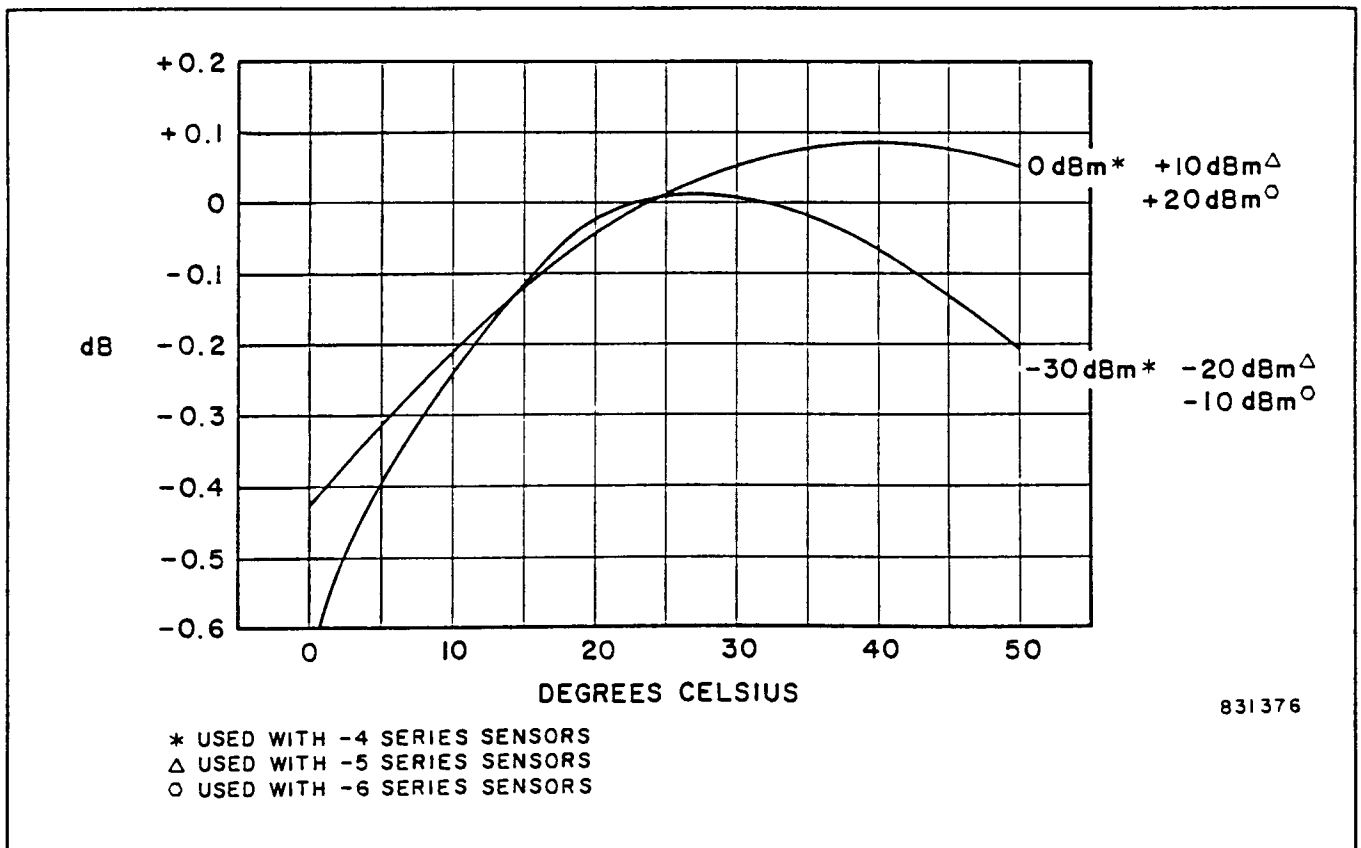

Figure 3-4 Typical Combined Temperature Characteristics of Instrument and Sensor

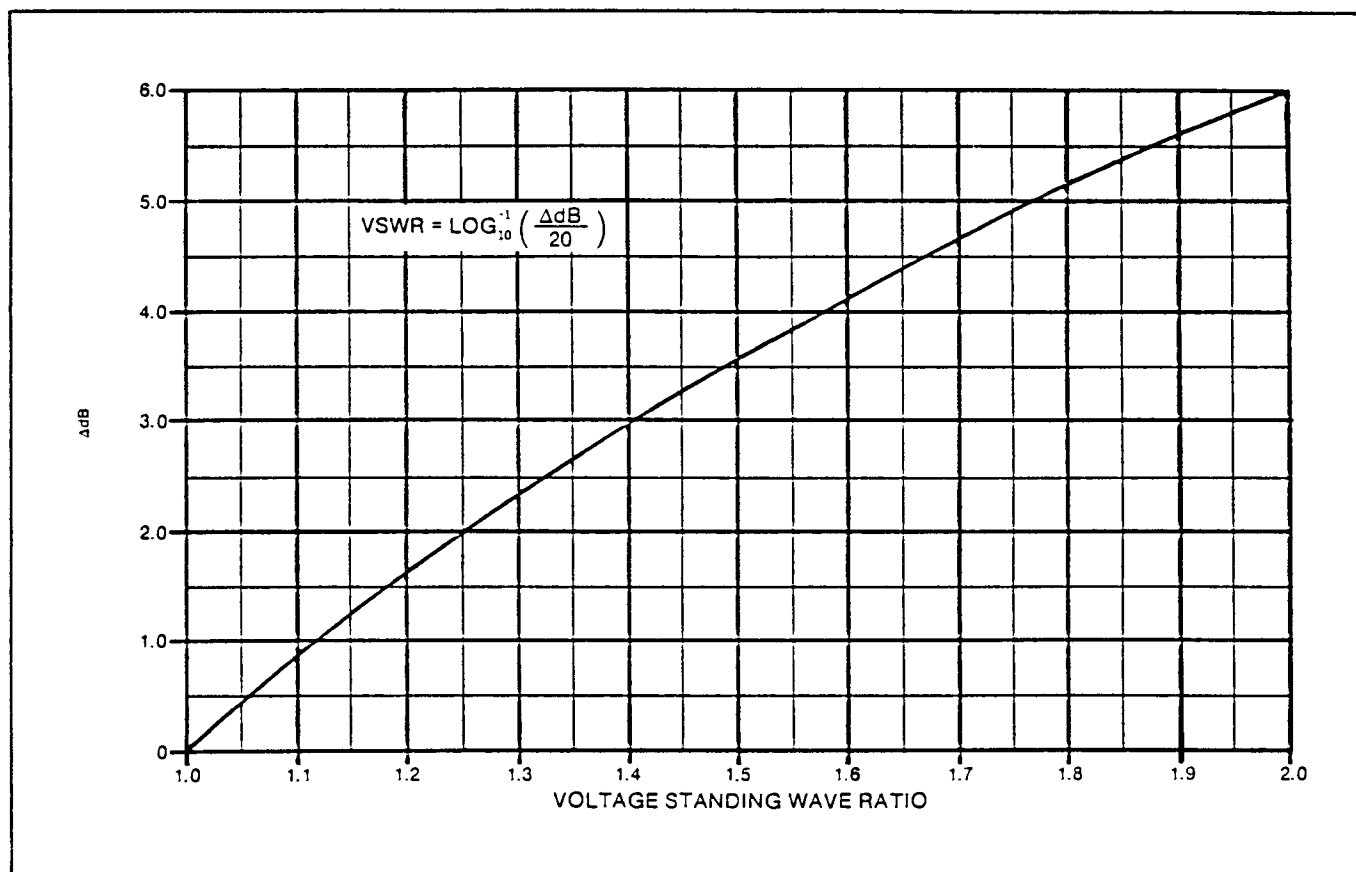

Figure 3-5 dB-SWR Conversion Chart

3-32. Shielding Recommendations. If the instrument is subjected to strong noise fields, accurate zeroing may be difficult unless the sensor is shielded during the zeroing operation. The simplest method of shielding is to connect the sensor to the device whose power level is to be measured, first making sure that the device is turned off; however, in some instances, the device may act as an antenna and introduce additional noise voltage into the sensor. If this happens, disconnect the sensor from the device, stand the sensor, end down, on a copper plate, and hold it down firmly so that the rim of the sensor connector makes good contact with the copper plate at all points. Alternatively, wrap a piece of thin copper foil around the threaded portion of the connector body, and crimp the foil around the open end of the connector, making certain that the center pin of the connector is not shorted. If frequent zeroing in strong noise fields is necessary, construct an adapter, using a Type N connector permanently fitted with a copper foil shield.

3-33. Analog Output. A dc voltage proportional to either power or dBm is available at rear panel recorder connector J20 for recorder or other applications. This output voltage will be affected in both power and dB

modes by calibration factor entries. The source resistance of the recorder output is approximately 9000 ohms, permitting a current of 1 mA into a load of 1000 ohms at full scale power. Output levels for various measurement modes are as follows:

a. In the power mode, the dc output level is proportional to the displayed power, with 10 volts at full scale for each range.

* b. In the dB mode, the dc output level is proportional to dBm according to the formula (Series 4/7/K/KA/Q Sensors)

$$V \text{ OUT} = \left(8 + \frac{\text{dBm}}{10} \right) \text{ volts}$$

Example:

The voltage output at -20 dBm would be:

$$\left(8 + \frac{-20}{10} \right) \text{ volts} = 6 \text{ volts}$$

This output is a function of dBm only, but is affected by CAL FACTOR entries.

Section III
Operation

* c. In the Channel-3 mode of operation (Option -03), the recorder output is proportional to the difference in dB of channel 1 minus Channel 2. This output is affected by both the calibration factors and the dB reference levels entered in each channel. The equation is:

RECORDER OUT (VOLTS)

$$= \left[\frac{(\text{dBch.1} + \text{dB CAL FACT CH1} - \text{dB REF.ch.1})}{10} - \frac{(\text{dBch.2} + \text{dB CAL FACT CH2} + \text{dB REF.ch.2})}{10} + 8 \right]$$

Or. equivalent:

$$\text{RECORDER OUT (VOLTS)} = \frac{\text{dB}_{\text{display}}}{10} + 8$$

Valid recorder outputs will be obtained for display indications of -80 dB (0 volts) to +30 dB (11 volts).

3-34. MINIMUM PERFORMANCE STANDARDS.

3-35. Test Equipment Required. For minimum performance testing of the instrument, an adjustable power source, such as the Boonton Electronics Corporation Model 25A Power Meter Calibrator, and a dc voltmeter or oscilloscope capable of measuring 0 to +10 volts are required.

3-36. Preliminary Setup.

a. Turn on the instrument and the adjustable power source and allow sufficient warmup time. If either unit had been stored at ambient temperatures substantially different from the ambient temperature at the minimum performance test facility, make sure enough time is allowed for each device to reach ambient temperature.

b. Set the adjustable power source output to zero, and connect the sensor between the adjustable power source and the front-panel SENSOR connector of the instrument, using the sensor cable.

c. Key in the following measurement parameter data through the keyboard:

```
I SELECT CHNL
N SELECT SENS (N = number of sensor being used)
MODE dB
RANGE AUTO
dB LIMITS — any
0 CAL FACTOR dB
0 REF LEVEL dB
```

NOTE

Maintain the same measurement parameters

for each of the following tests unless specifically directed otherwise.

3-37. Automatic Zero Function Test. To check the automatic zeroing function of the instrument, proceed as follows:

a. Ascertain that the signal input to the sensor is zero.

NOTE

Do not confuse 0 dB with zero input. For zero input to the sensor, turn off the adjustable power source.

b. Press the ZERO key and ascertain that the logic signal level at pin 3 of rear-panel connector P3 switches from a logic low to a logic high when the ZERO key is pressed, remains high throughout the zeroing period (approximately 26 seconds), and returns to a logic low at the end of the zeroing period. During zeroing, the front-panel LED display should show the following:

Display	Comment
cccc	Zeroing
cc03	Zeroing complete

3-38. Autoranging Mode Test. To check the autoranging function of the instrument, set the output level of the adjustable power source to each of the values listed below and ascertain that the instrument LED display readout agrees with the input power level within ±0.2 dB

- +10 dBm
- 0 dBm
- 10 dBm
- 20 dBm
- 30 dBm
- 40 dBm
- 50 dBm

NOTE

For lowest ranges, rezero if necessary.

3-39. Range Hold Function Test. To check the range hold function of the instrument, proceed as follows:

a. Set the output level of the adjustable power source to 0 dBm.

b. Press the RANGE HOLD key and the MODE PWR key.

c. Ascertain that the LED display readout is 1.000 mW ±1.2%.

d. Set the adjustable power source output to each of the following levels in succession, and ascertain that the

corresponding listed LED indications are obtained on the instrument:

Power Source Level	Instrument Indication
10 mW	cc04 (power level too high)
1 mW	1.000 mW
100 μ W	0.100 mW
10 μ W	0.010 mW
	or
	cc03 (if less than 10 counts; power level too low)

- e. Press the RANGE AUTO key.

NOTE

When the range hold function is selected, input power levels greater than the power decade operative when the selection was made will result in overranging of the instrument and display of an error indication; lower input levels result in a decrease in the number of significant digits in the display. Note that the decimal point and annunciator remain fixed.

3-40. Basic Instrument Accuracy Test. To check the basic accuracy of the instrument, proceed as follows:

- With zero input to the sensor (adjustable power source turned off), zero the instrument by pressing the ZERO key.
- Connect the sensor to the POWER REF connector. Press the CAL key.
- Upon completion of calibration, press the MODE dB key, and connect the sensor to the adjustable power source.
- Set the output level of the adjustable power source to each of the following dBm values in succession, and ascertain that the LED display readout agrees with the output level of the adjustable power source within the specified dB limits:

Power Source Level	LED Display Tolerance
-50 dBm	± 0.1 dB
-40 dBm	± 0.05 dB
-30 dBm	± 0.05 dB
-20 dBm	± 0.05 dB
-10 dBm	± 0.05 dB
0 dBm	± 0.05 dB
+10 dBm	± 0.05 dB
-1 dBm	± 0.055 dB
-2 dBm	± 0.06 dB
-3 dBm	± 0.065 dB
-4 dBm	± 0.07 dB
-5 dBm	± 0.075 dB
-6 dBm	± 0.08 dB

Power Source Level	LED Display Tolerance
-7 dBm	± 0.085 dB
-8 dBm	± 0.09 dB
-9 dBm	± 0.095 dB

NOTE

If the dBm indications are within limits, it may be assumed that power mode indications are also within limits; dBm indications are computed from power measurements within the instrument.

3-41. Power Mode Test. To test operation of the instrument in the power measurement mode, proceed as follows:

- Without disturbing any measurement parameters used in preceding paragraph, adjust the output level of the adjustable power source to 0 dBm and ascertain that the LED display of the instrument indicates 0 dBm ± 0.05 dB.
- Press the MODE PWR key. The LED display should indicate 1.00 mW $\pm 1.3\%$.
- If desired, other power levels may be checked in similar fashion. To determine the proper power indication for a specific dBm input level, use the formula:

$$P = \log^{-1} \text{ dB} / 10 \text{ (mW)}$$

3-42. Calibration Test. To check the automatic calibration capability of the instrument, proceed as follows:

- Set the power source to 1.0 mW.
- Select the power mode and autoranging.
- Enter a 0 dB calibration factor.
- Note the indication of the LED display. If the indication is not 1.000 mW, press the CAL key, and ascertain that the indication is now 1.000 mW ± 2 counts (± 4 counts with ± 200 -5 sensors).
- If an indication of exactly 1.000 mW is obtained originally in step d, enter a calibration factor of 0.03 dB to cause the indication to increase to approximately 1.01 mW. Then, press the CAL key and ascertain that the indication changes to 1.000 mW ± 2 counts. Enter a 0 dB calibration factor and press the CAL key to restore the original indication.
- The automatic CAL function is operative at all 10 dB points if a suitable signal source is available; operation is as in steps a thru e, except for the input signal level and range.

NOTE

For greatest overall accuracy, however, it is strongly recommended that this feature be used with the 50

Section III Operation

MHz power reference which provides an accurate 1 mW level.

3-43. Sensor Selection Test. Entry of the correct number for the sensor in use is absolutely essential for instrument accuracy. Data for each sensor supplied with the instrument has been entered and stored in micro-processor memory at the factory. Stored data consists of functions peculiar to each sensor, such as sensitivity, calibration factors, etc. A direct, absolute check of the sensor data is not possible; however, the basic instrument accuracy test (paragraph 3-40) and the calibration test (paragraph 3-42) provide a good indication of satisfactory operation of the sensor selection function. Entry of an incorrect sensor number will probably result in degradation of basic accuracy. Sensor serial numbers can be recalled from non-volatile memory by keying in a decimal point followed by SELECT SENS.

3-44. dB Reference Level Function Test. To check the dB reference level function of the instrument, proceed as follows:

- a. Set the output power level of the adjustable power source to 0 dBm.
- b. Press the MODE dB key and ascertain that the LED display indicates 0 dBm ± 0.05 dB.
- c. Enter a -10 dB reference level by pressing the following keys:

1
0
CHS
REF LEVEL dB

- d. Ascertain that the LED display now indicates +10 dBr ± 0.05 dB. The dBm annunciator should be off, and the dBr annunciator should be lighted.
- e. Reset the instrument to indicate dBm by pressing the following keys:
0
REF LEVEL dB
- f. Ascertain that the LED display again indicates 0 dBm ± 0.05 dB. The dBm annunciator should be lighted, and the dBr annunciator should be off.

3-45. dB Limit Test. To check operation of the dB limit circuits, proceed as follows:

- a. Set the output level of the adjustable power source to 0 dBm.
- b. Enter a +1 dB high limit by pressing the following keys:
1
dB LIMITS HI
- c. Enter a -1 dB low limit by pressing the following keys:

1
CHS
dB LIMITS LO

- d. Ascertain that the LIM annunciator is off.
- e. Set the output level of the adjustable power source to -2.0 dBm. The LIM annunciator should light. The logic level at pin 5 of rear-panel connector P3 should be high; the logic level at pin 4 of connector P3 should be low.
- f. Set the output level of the adjustable power source to +2.0 dBm. The LIM annunciator should be lighted. The logic level at pin 4 of rear-panel connector P3 should be high; the logic level at pin 5 of the connector P3 should be low.

NOTE

Limits can be entered only in terms of dB, not power; however, the limit function operates in both the dB mode and the PWR mode.

- g. Set the input level to -7 dBm. Press the CLR and the REF LEVEL dB keys: the indication should be approximately -7.00 dB. Press the decimal-point and the REF LEVEL dB keys: the display should now indicate 00.00 dB. Recall the dB reference level by pressing the REF LEVEL dB key: the indication should be -7.00, showing that the original dBm level is now stored as the dB reference level. Press the CLR and the REF LEVEL dB keys: indication now should be -7.00 dBm, showing that the reference level is now 0 dBm. Note that, as discussed paragraph 3-19 (page 3-8), this method of entering current dBm level as the dB reference level is operative only in the local mode—not in IEEE-488 interface mode.

3-46. Calibration Factor Test. To check operation of the calibration factor function, proceed as follows:

- a. Set the output level of the adjustable power source to 0 dBm.
- b. Press the MODE dB key and note the indication on the LED display.
- c. Enter a 0.2 dB calibration factor by pressing the following keys:

0
.
2
CAL FACTOR dB

- d. Ascertain that the indication on the LED display is equal to the value noted in step b plus 0.2 dB.
- e. Enter a 2 GHz calibration factor by pressing the following keys:

2
CAL FACTOR GHz

- f. Determine the calibration correction for 2 GHz from the chart on the barrel of the sensor. Ascertain that the

LED display indicates the value noted on the chart on the sensor barrel.

NOTE

For proper calibration factor correction and instrument accuracy, it is essential that the sensor number entered into the instrument prior to measurement agrees with the number indicated on the barrel of the sensor used for the measurement. Calibration factors that are invoked are operative in both the dB mode and the PWR mode.

NOTE

If the instrument is equipped with the -03 option, repeat the minimum performance standards tests for channel 2.

SECTION IV THEORY OF OPERATION

4-1. INTRODUCTION.

4-2. The instrument is a general purpose RF microwatt-meter capable of measuring power levels from 1 nW (-60 dBm) to 1 W (+30 dBm). It is designed to operate in conjunction with Boonton Electronics Corporation Series 4200 power sensors. The usable frequency range depends upon the sensor used with the instrument. The lowest usable frequency for *calibrated* measurements is 0.2 MHz; the highest frequency is 110 GHz.

4-3. The instrument is a completely solid-state unit that employs a microprocessor for versatility in use. The microprocessor is controlled by a permanently stored, internal program; pertinent operating parameters can be entered by means of a front-panel keyboard. Use of a microprocessor enables automation of numerous functions, such as zeroing, calibration, sensor calibration, range selection, unit conversion, dB limit testing, relative dB measurements, etc. Measured values are displayed directly on a 4 digit LED display in terms of nW, μ W, mW, dBm, or dBr (relative dB). Annunciators associated with the display indicate the unit of measurement. A meter is also provided for relative power measurements; this feature simplifies such operations as nulling and peaking.

4-4. OVERALL BLOCK DIAGRAM. (See Figure 4-1.)

4-5. **Sensor.** Power levels to be measured are applied to an external sensor, which is connected to a front-panel connector through a five-foot sensor cable. Input power appears across a precision resistor (50 or 75 ohms, depending upon the sensor model). Because the resistance value is constant, the voltage developed across the resistor is a function of input power ($E^2 = PR$). The RF voltage developed across the resistor is converted to a DC voltage, and the resulting DC voltage is applied to the input module of the instrument.

4-6. **Input Module.** The input module receives the DC voltage developed by the sensor. Operating under control of the control module, the input module converts the DC signal to an AC signal, amplifies the AC signal, converts the amplified AC signal to an analog DC signal, and converts the analog DC signal to a digital signal. If the autoranging function of the instrument is being used, the gain of the amplifiers in the input module is adjusted automatically by the control module to accommodate any power level within the range of the instrument. The digital output signal of the input module is supplied to the

control module for further processing; an analog DC output signal is developed from the digital signal and applied to the analog meter on the display module for relative power measurements, and to a rear-panel connector for application to a peripheral recorder.

4-7. **Control Module.** The control module consists primarily of a pre-programmed microprocessor. The microprocessor accepts and stores measurement parameter commands entered through the front-panel keyboard, and controls operation of the internal circuits of the instrument in accordance with its program and keyed-in commands. The microprocessor performs measurement value corrections based on stored zero corrections and stored or keyed-in sensor calibration factors, unit conversions based on selected measurement modes, and dB limit determination. The microprocessor also performs automatic instrument zeroing and calibration. The processed digital signal, which defines the final measurement value, is applied to a data bus and to the display module.

4-8. **Display Module.** The display module contains the keyboard and LED display circuits. Parameters to be used for power measurements can be entered at any time through the keyboard. Keyed-in values are read and stored by the microprocessor, and selected numerical values are shown on the LED display during parameter selection. Computed power levels are processed by the microprocessor in accordance with the keyed-in parameters; the digital values representing the final computed measurement values are decoded by the display module circuits to produce a direct LED readout of measured values and to activate the appropriate annunciators.

4-9. **Power Reference.** The power reference module generates a precision, 1.00 mW, 50 MHz signal that is used for calibration of the instrument. When this signal is applied to the sensor and the front-panel CAL key is pressed, fine sensitivity adjustments of the instrument are performed automatically under microprocessor control.

4-10. **Power Supply Module.** The power supply module provides all DC voltages required for operation of the internal circuits. It also provides a reset signal to the control module when it is powered up, and an interrupt signal if an undervoltage condition is detected. The standard power supply module can be powered from a 100, 120, 220, or 240 volt, 50 to 400 Hz, AC power source.

4-11. **Optional Modules.** Standard options are available to further increase the versatility of the instrument. Two of these optional modules are shown in Figure 4-1.

Section IV
Theory of Operation

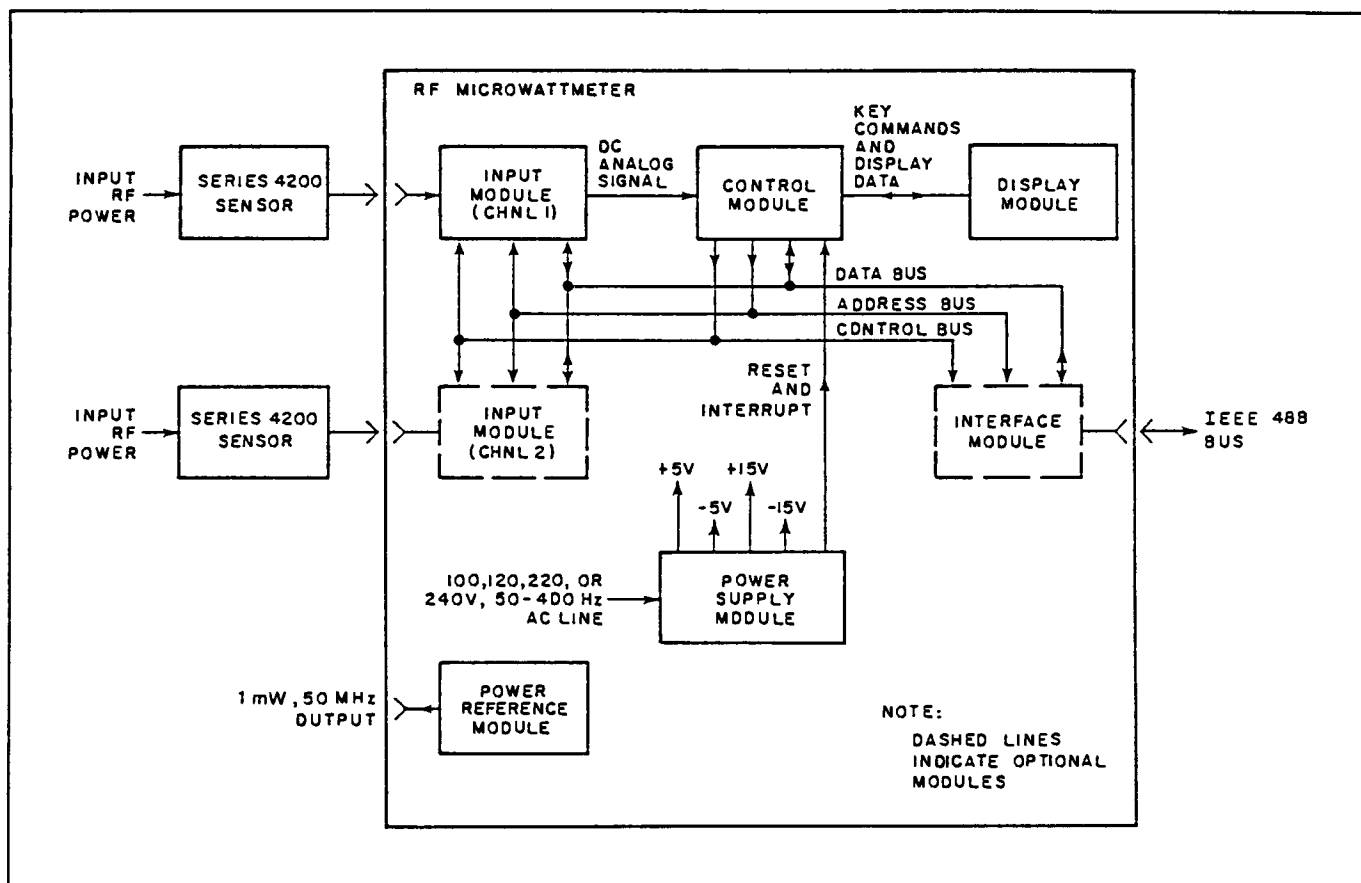

Figure 4-1 Overall Block Diagram

a. A second input module can be added to the instrument to permit measurement of output power levels of two devices without the need for repeated switching of sensor connections. The input connector for this optional module is located on the rear panel of the instrument. The second input module also permits LED display of the difference between the power levels of the two devices, expressed in dB.

b. The interface module provides an IEEE 488 bus interface for remote control of instrument operation and for remote display of measured values.

4-12. DETAILED THEORY OF OPERATION, SENSOR CIRCUITS.

(See Figure 4-2.)

4-13. The sensor contains two paralleled precision resistors (50-ohm effective total resistance for Models 4200-4A, 4200-4B, 4200-4E, 4200-5B, 4200-5E, and 4200-6E, and 75-ohm effective total resistance for Model 4200-4C) across which the input power is applied. With a constant load resistance, the RF voltage developed across the load resistance is a function of the RF power ($E^2=PR$). The RF voltage is rectified by a full-wave rectifier that permits measurement of highly asymmetrical waveforms without sub-

stantial error. When the applied power level is within the square-law region of the diodes (up to approximately 20 μ W), the sensor has a true RMS response. Above this power level, the sensor response approaches peak-to-peak, calibrated in the instrument in terms of true average power.

NOTE

Series 4200-5 and 4200-6 sensors have input attenuators; this permits measurements to 100 mW (+20 dB) and 1000 mW (+30 dB) respectively.

4-14. The body of the sensor has been designed and fabricated very carefully to eliminate any cavity resonance effects within the calibrated frequency range and to minimize noise. The sensor diodes are specially selected for this application. The DC output voltage of the sensor is applied to the input connector of the instrument through a low-noise sensor cable.

4-15. DETAILED THEORY OF OPERATION, INPUT P.C. BOARD CIRCUITS.

(See Figure 4-3).

4-16. The input printed circuit board receives from the sensor a DC voltage that is a function of the power level being measured. Under control of the control board

circuits, it provides amplification and signal processing required to develop an analog DC voltage and a digital signal that are proportional to the input RF power level. The input DC signal from the sensor is balanced in form and may vary from microvolts to volts, depending upon the input power level. The input printed circuit board must provide amplification with a wide range of gain, low offset voltage, and low noise; therefore, the input DC signal is converted to an AC signal which is amplified, and the amplified AC signal is converted to a DC analog signal and to a digital signal.

4-17. The input DC signal is converted to an AC signal by a chopper module, which plugs into the input printed circuit board. The chopper is composed of solid-state switches IC1a, IC1b, IC1c, and IC1d in a balanced arrangement, operating at a frequency of approximately 94 Hz to minimize AC line and line-related component interaction. The chopper drive signal is derived from the output of an astable multivibrator, which is completely independent of line frequency. The use of a solid-state chopper eliminates many of the problems, such as contact wear and contamination, associated with electromechanical choppers. The chopper supplies a balanced AC signal of approximately 94 Hz to the input amplifier.

4-18. The 94 Hz drive signal for the chopper is derived from the output signal of astable multivibrator IC5. Multivibrator IC5 drives flip-flops IC7a and IC7b, and these flip-flops supply the drive signal to the chopper circuits. Flip-flop IC7a also drives flip-flops IC8a and IC8b, which provide a 94 Hz, synchronized drive signal to the demodulator circuits that convert the amplified AC signal back to a DC signal.

4-19. Amplification of the balanced AC signal from the chopper is accomplished in an input amplifier composed of low-noise, operational amplifiers A5, A6, and A7. A balanced arrangement with degenerative feedback for stabilization and gain control is employed. The input AC signal is amplified by 500, 50, 5, or 0.5, depending upon the instrument range. Demultiplexer IC6, under control of the control printed circuit board, adjusts the degenerative feedback in accordance with the range selected by the microprocessor to provide the required gain switching. An attenuator at the output of the input amplifier provides attenuation of 2 for the highest range only; on all other ranges its attenuator is zero. This attenuator is switched into the circuit on the highest range through solid-state switches IC10a, IC9b, and IC9c. Demultiplexer IC13 decodes digital signals that define the range from the microprocessor and activates the solid-state switches on the highest instrument range.

4-20. The amplified 94 Hz signal is converted to a DC analog signal by means of a demodulator circuit that operates in synchronism with the chopper. The demodulator consists essentially of a sample and hold switch, composed of solid-state switches IC10b and IC10c and associated circuitry. Switches IC10b and IC10c are controlled by the 94 Hz drive signals from flip-flops IC8a and IC8b. The sampling point and period of the sample and hold circuit has been chosen to minimize switching products and noise, and to vary signal averaging in accordance with the signal level. Switch IC9a adjusts operating parameters automatically in accordance with instrument range; the switch is activated through gates IC11b and IC11c and demultiplexer IC13 on the four highest ranges.

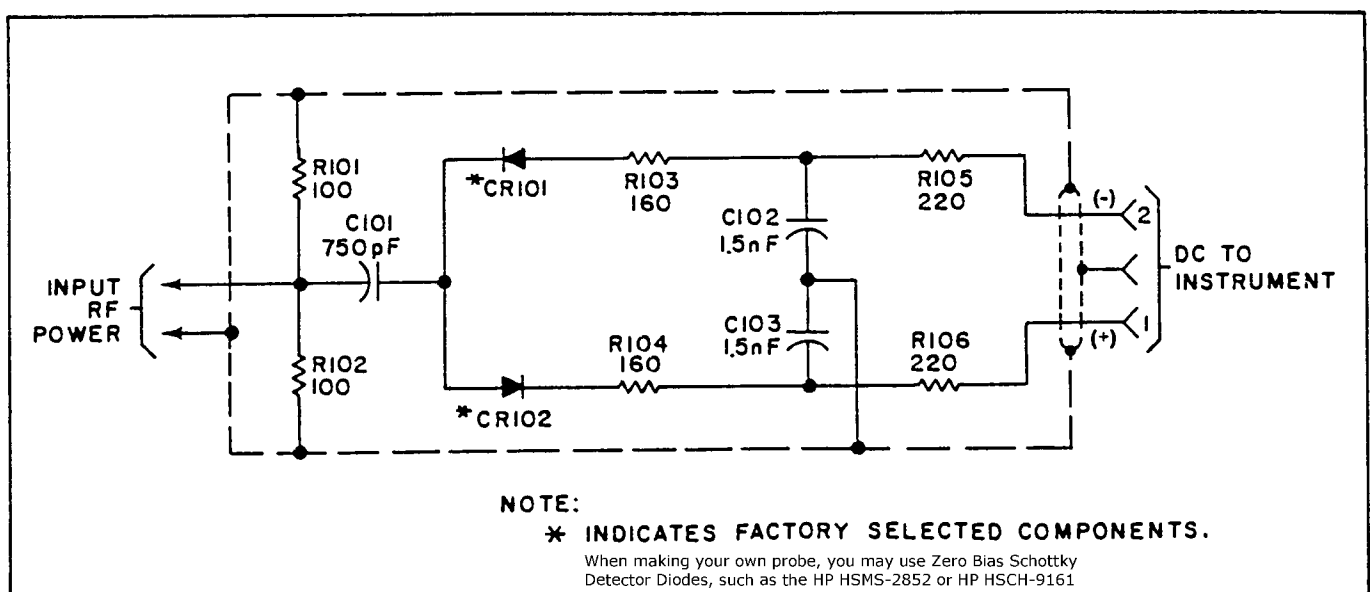

Figure 4-2 Typical Series 4200 Sensor, Schematic Diagram

Section IV Theory of Operation

4-21. The DC output voltage of the sample and hold circuit is amplified by an amplifier circuit composed of integrated circuits A8, A9, and IC14, and associated circuitry. Integrated circuit IC14 is a demultiplexer which decodes microprocessor-supplied digital signals that define the selected range and adjusts an attenuator circuit accordingly; the gain of the amplifier is 125, 12.5, or 1.25, depending upon the selected range. The full-scale output voltage of the amplifier is 2.25 volts nominal on each range.

4-22. The DC output voltage of integrated circuit A9 is usually unipolar and positive; however, during the automatic zeroing process of the instrument, the DC output voltage may be positive or negative, depending upon small DC offsets. Because some of the following circuits operate only with unipolar signals, a polarity switch is required. This polarity switch, which consists of solid-state switches IC3b and IC3c, operates under control of the microprocessor on the control printed circuit board, which tests for polarity. The DC voltage is routed through the polarity switch to the appropriate input of operational amplifier A3 so that the output DC from this amplifier is always negative. This output voltage is applied to a comparator circuit.

4-23. Comparator A2 operates in conjunction with the microprocessor on the control printed circuit board and D/A converter IC2 to convert the DC output signal of amplifier A3, which is proportional to the input power, to a digital signal that can be processed by the microprocessor circuits. D/A converter IC2 is supplied with successive half-level digital signals (full scale/2, full scale/4, etc.) by the microprocessor. D/A converter IC2 converts these digital signals to a DC analog voltage, and this analog DC voltage is applied through amplifier A1 to comparator A2, where it is compared with the DC signal from amplifier A3. The difference signal from comparator A2 is supplied to the microprocessor through interface IC1 so that the microprocessor can monitor the results of the comparison and adjust the digital signal accordingly. The digital signal is adjusted by the microprocessor until the two input signals to comparator A2 are equal. The resulting digital signal then defines the input DC level being measured. This digital signal is then processed (zero correction, calibration correction, unit conversion, etc.) by the microprocessor before application to the LED display circuits of the instrument.

4-24. After the digital signal has been fully processed by the microprocessor, the processed digital signal is again supplied by the microprocessor to D/A converter IC2, which converts the processed digital signal to a corresponding DC analog voltage that is used to drive the front-panel meter and the recorder output of the instrument. This DC analog voltage from D/A converter

IC2 is supplied through amplifier A1 to sample and hold switch IC3a, which is closed at this time by a control signal from the microprocessor. The DC analog voltage at the output of the sample and hold circuit is applied through amplifier A4 and the control printed circuit board to the display printed circuit board.

4-25. All interfacing between the input printed circuit board and the microprocessor is accomplished through interface IC1. Interface IC1 is an input/output device that operates under control of the microprocessor. When signal \overline{RD} is activated by the microprocessor, data are transferred from the input printed circuit board to the microprocessor, provided that signal \overline{CS} to interface IC1 is also active; when signals \overline{WR} and \overline{CS} are both activated by the microprocessor, data are transferred from the microprocessor to the input printed circuit board. Data flow between the input printed circuit board and the microprocessor over the eight-line bi-directional data bus. Routing of data through the interface is controlled by the address signals supplied to the interface by the microprocessor.

4-26. DETAILED THEORY OF OPERATION, CONTROL P.C. BOARD. (See Figure 4-4.)

4-27. The operation of the instrument is controlled by a microprocessor contained on the control printed circuit board. The control printed circuit board is organized around a central processing unit (CPU), associated memories, input/output ports, and a 40-line bus. A stored program, in conjunction with key-entered commands, enables the microprocessor to perform a variety of functions, including the following:

- a. Analog to digital conversion
- b. Zero determination
- c. Zero correction
- d. Ranging
- e. Calibration
- f. Signal processing
- g. Binary to BCD conversion
- h. dB conversion
- i. dB reference conversion
- j. dB limit testing
- k. Diagnostics.

4-28. Integrated circuit IC3 is the microprocessor CPU. It is an 8-bit unit that operates at a clock frequency of 2 MHz, generated by integrated circuits IC1a through IC1c and associated circuitry. The operating program for the microprocessor is stored in integrated circuits IC6 and IC7, which are programmable read-only memories (PROMs). RAM IC8 provides temporary storage of data during operation of the instrument. It also stores certain measurement parameters such as, sensor data, calibration fac-

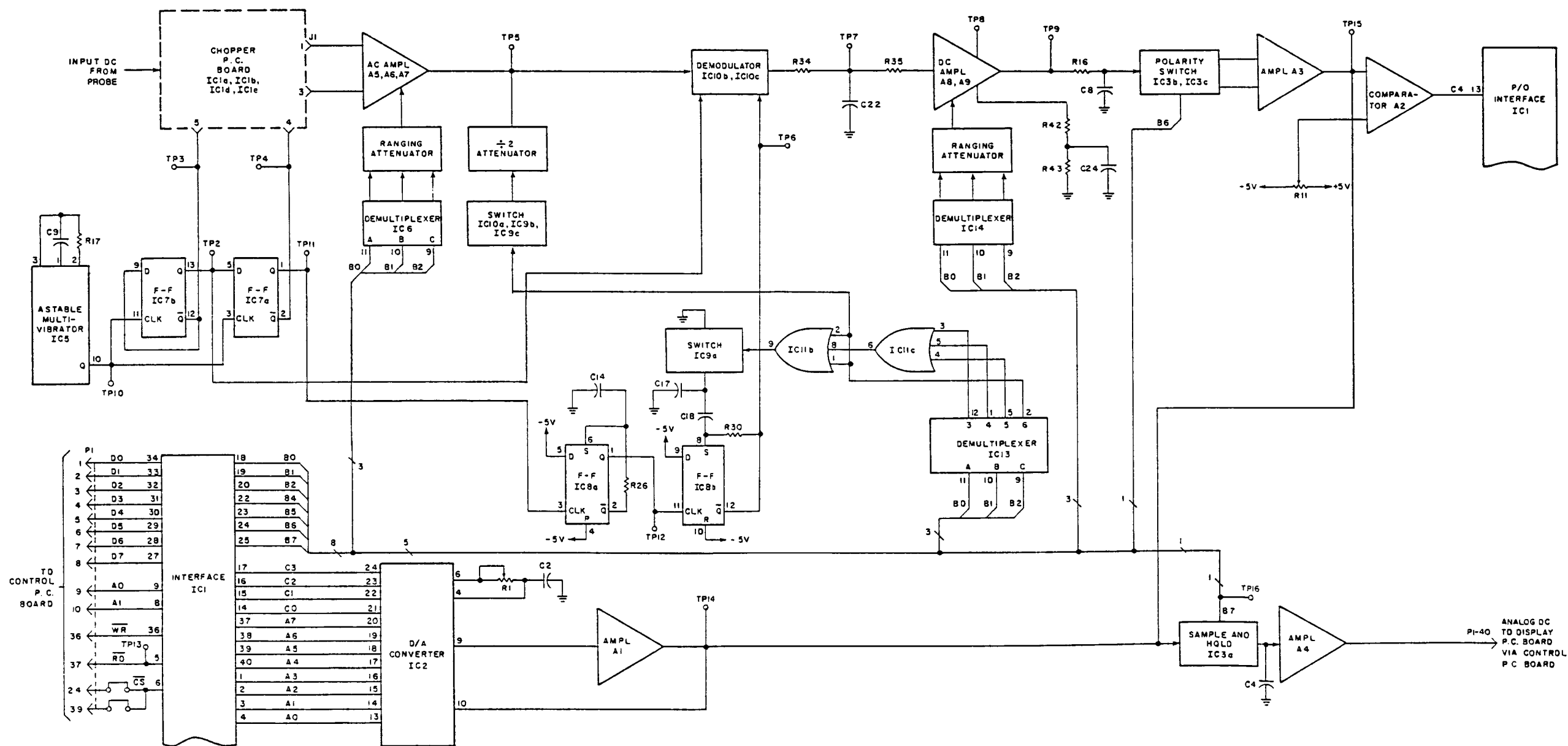

C831450A

Figure 4-3 Input P.C. Board, Detailed Block Diagram

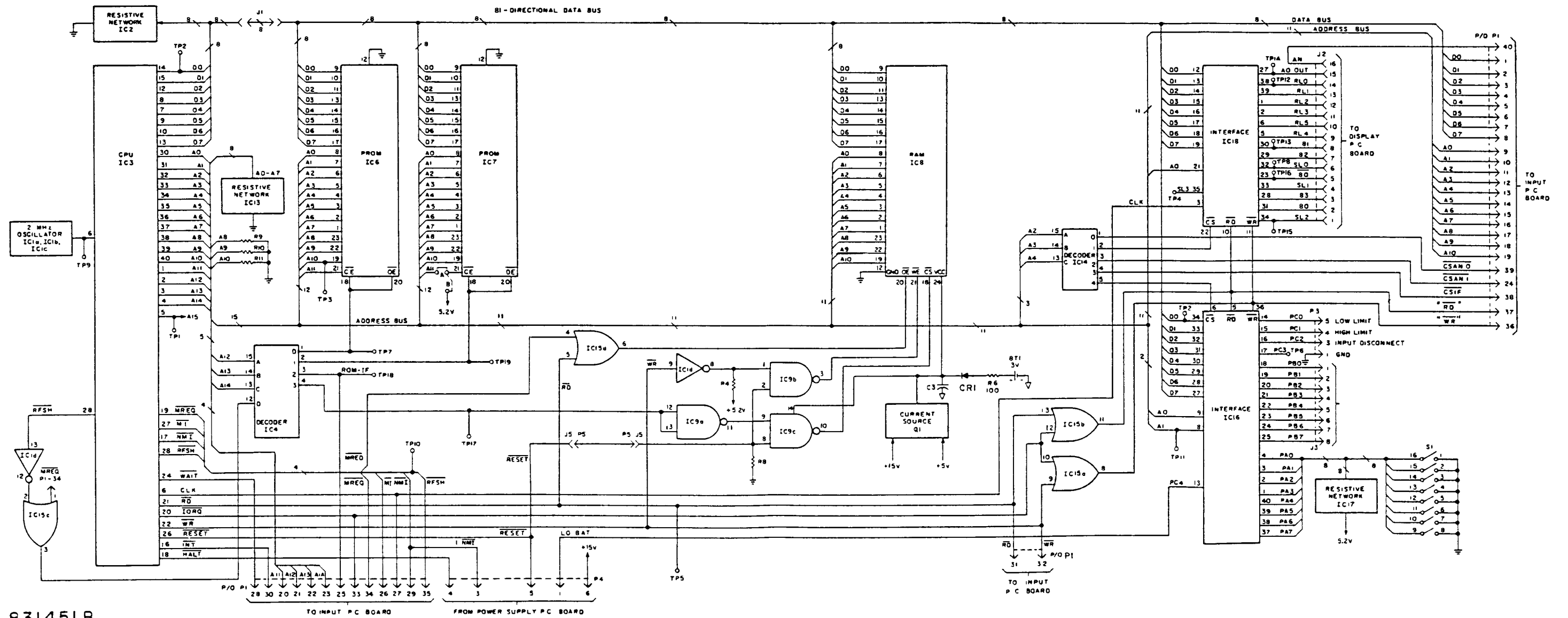

831451B

Figure 4-4 Control P.C. Board, Detailed Block Diagram

tors, some key-entered parameters, etc. Lithium-type battery BT1, which has an anticipated life of 10 years, supplies power to RAM IC8 during power-down of the instrument to enable retention of data in memory. During normal operation, RAM IC8 is powered by transistor Q1. Integrated circuit IC16 is an I/O port which interfaces with the following:

- a. An 8-bit switch used to set the mode of operation, number of channels, and number of sensors.
- b. A test socket (J3) used in signature analysis.
- c. A plug (P3) for output of status information.

4-29. The CPU receives and transmits data over an eight-line data bus. A 15-line address bus is used for addressing, and a control bus is used for various control functions. When the instrument is turned off, signal $\overline{\text{RESET}}$ is activated by the power supply circuits and the microprocessor is reset to the start of the operating program; when the instrument is next turned on and DC voltages have reached the correct operating levels, the $\overline{\text{RESET}}$ signal is deactivated by the power supply circuits and the microprocessor begins to execute the stored program. Instructions are retrieved from storage by the CPU in accordance with the address code developed at its output. Decoder IC4 enables the appropriate PROM (IC6 or IC7), and the instruction contained in the memory location defined by the address on address lines A0 through A11 is read and transmitted by the CPU over the data bus. The CPU then executes this instruction.

4-30. During the measurement process, the CPU must retrieve data from storage and from the input and display printed circuit boards, it must store temporary calculation values, and it must output data to the input and display printed circuit boards. To retrieve data from memory, the storage device and data location are defined by the address supplied by the CPU, and signals $\overline{\text{MREQ}}$ and $\overline{\text{RD}}$ are activated. Integrated circuit IC4 decodes three of the address bits to activate signal $\overline{\text{CS}}$ at RAM IC8 through gates IC9a and IC9c. Signal $\overline{\text{OE}}$ at RAM IC8 is activated through gate IC15d, and data stored at the location specified by the remaining address bits are transmitted over the data bus to the CPU or to other circuits connected to the data bus. To access data developed by circuits outside the control printed circuit board, the CPU activates signals $\overline{\text{IORQ}}$ and $\overline{\text{RD}}$ along with the appropriate address lines. Decoder IC14 decodes three address bits to develop enabling signal $\overline{\text{CS}}$ for interface IC16, integrated circuit IC18, or interface IC1 on the input printed circuit board, as specified by the three address bits, and gate IC15b activates signal $\overline{\text{RD}}$ for the read function. If integrated circuit IC18 is

enabled, keyed-in commands from the display printed circuit board, which had been stored in integrated circuit IC18, are transmitted over the data bus. If integrated circuit IC16 is enabled, input data from bit switch S1 or power supply connector P4, as determined by address bits A0 and A1, are supplied through interface IC16 to the data bus. If interface IC1 on the input printed circuit board is enabled, data generated on the input printed circuit board are transmitted over the data bus through interface IC1.

4-31. To store data, the CPU activates signal $\overline{\text{WR}}$ and the address lines that define the storage device and storage location. Decoder IC4 decodes three address bits to enable signal $\overline{\text{CS}}$ at RAM IC8, signal $\overline{\text{WR}}$ enables the write function of RAM IC8 through inverter IC1d and gate IC9b, and data on the data bus are written into memory at the location defined by the remaining address lines. To output data to circuits outside the control printed circuit board, signal $\overline{\text{IORQ}}$ is activated by the CPU in addition to the previously mentioned signals. Signals $\overline{\text{IORQ}}$ and $\overline{\text{WR}}$ activate the write enable signal to the device defined by the address bits. Decoder IC14 decodes three address bits to select the appropriate device (interface IC16, interface IC18, or interface IC1 on the input printed circuit board). Data on the data bus are then transferred to the selected device. If interface IC16 is selected, these data are transferred through interface IC16 to connector P3 or J3, as determined by address bits A0 and A1. The output to connector P3 consists of dB out-of-limit signals and an input disconnect signal which is active when the automatic zeroing function is selected. The output data at connector J3 are used in signature analysis checks. If interface IC18 is selected, the data on the data bus are written into storage in interface IC18 for application to the display printed circuit board. These data are then clocked out of storage to activate the LED display and annunciators on the display printed circuit board. If interface IC1 on the input printed circuit board is selected, data on the data bus are transferred through the interface to control various functions on the input printed circuit board.

4-32. Connector J1 is included in the data bus on the control printed circuit board to facilitate signature analysis maintenance of the microprocessor circuits. When connector J1 is pulled out, the data bus is disconnected from the CPU, and the CPU executes successive NOPs for free-running signature analysis checks.

4-33. The CPU receives two control signals directly from the power supply printed circuit board. If the power supply voltage should drop during operation, or on equipment turn-off, signal $\overline{\text{NMI}}$ is activated by the power supply circuits; the CPU, upon receipt of this signal

Section IV Theory of Operation

activates signal $\overline{\text{HALT}}$, and halts further execution of the program. Signal $\overline{\text{HALT}}$ is applied to the power supply printed circuit board, where it latches signal $\overline{\text{RESET}}$ to the active state. Signal $\overline{\text{RESET}}$, in turn, causes the microprocessor to return to the starting point of the program. When the power supply rises to a level approximately 150 millivolts below its nominal value, either as a result of correction of the undervoltage condition or of power turn-on, signal $\overline{\text{RESET}}$ is deactivated to permit execution of the stored program by the microprocessor.

4-34. DETAILED THEORY OF OPERATION, DISPLAY P.C. BOARD. (See Figure 4-5.)

4-35. The display printed circuit board contains the instrument LED display, meter, annunciators, keyboard, and control circuits for these items. It interfaces directly with the control printed circuit board. When any keyboard key is pressed, the microprocessor on the control printed circuit board interrupts the normal measurement process and accepts and stores the key-entered commands; the microprocessor also supplies digital data to the display printed circuit board to cause keyed-in numerical values to appear on the LED display; the microprocessor resumes the normal measurement process when any of the terminator keys (dB LIMITS, CAL FACTOR, SELECT, REF LEVEL dB) is pressed. Upon completion of the measurement by the microprocessor, measurement values are supplied to the display printed circuit board.

4-36. Operation of the display printed circuit board is controlled by the microprocessor through integrated circuit IC18 on the control printed circuit board, which provides the following functions:

- a. It provides a RAM for storage of microprocessor output data to the display printed circuit board.
- b. It provides a first-in, first-out RAM which accepts and stores input information (up to 8 key commands) from the display printed circuit board.
- c. It provides scan signals for both the LED display and the keyboard.

4-37. The LED display consists of four 7-segment displays, which provide a display capacity of four digits with decimal points, and a fifth display which is capable of displaying a minus sign. Each display consists of individual anodes for each segment that makes up the display and the decimal point, and a common cathode. The character that appears on the display is determined by the activated anodes at the time that the common cathode is scanned. The individual displays and the associated annunciators are scanned in sequence. The

display duty cycle is 12.5%; that is, each digit or annunciator of the instrument is on 12.5% of the time.

4-38. Digital information for the LED display and annunciators is developed by the microprocessor, and is stored in the output RAM contained in integrated circuit IC18 on the control printed circuit board. Digital information that defines display and annunciator row selection is supplied to 8-channel demultiplexer IC2. The output lines of demultiplexer IC2 are activated in sequence, based on the input digital codes. The signal on the active output line of demultiplexer IC2 is applied through resistive network IC5 to display driver IC7, and the display driver supplies driving power for the corresponding display and the corresponding row of annunciators. At the same time, digital data that define the display segments and the annunciators that are to be activated are supplied to decoder IC1. The binary-coded input is decoded by decoder IC1, and the output lines of the decoder are activated in accordance with this decode. The outputs of the decoder activate the individual anodes of the selected display and the individual annunciators in the active annunciator row, thereby providing the appropriate instrument display. A decimal point signal is applied through transistor Q1, when appropriate, to cause a decimal point to be displayed to the right of the character on the active display.

4-39. Demultiplexer IC2 also provides scanning signals to the keyboard. As each of its first five output lines is activated in sequence, a scan signal is applied to an individual row of the keyboard through an inverter. If any key in the row being scanned is pressed, a signal is supplied to one of the column output lines to the RAM in integrated circuit IC19 on the control printed circuit board, and the key command is stored by the RAM. Key selection is defined by a combination of the row scan signal and the column output line. The RAM can store up to a maximum of eight key commands, and it delivers this stored information to the microprocessor when it is read. Actuation of more than eight key commands without a read causes the RAM to be cleared.

4-40. Analog DC voltage, which is proportional to the measured power level, is supplied from the control printed circuit board to drive the front panel meter to provide a relative indication of measured power for peaking and nulling applications. This also supplies a DC analog voltage to rear-panel connector P1. This signal can be used to drive an external recorder.

4-41. DETAILED THEORY OF OPERATION, POWER REFERENCE P.C. BOARD. (See Figure 4-6.)

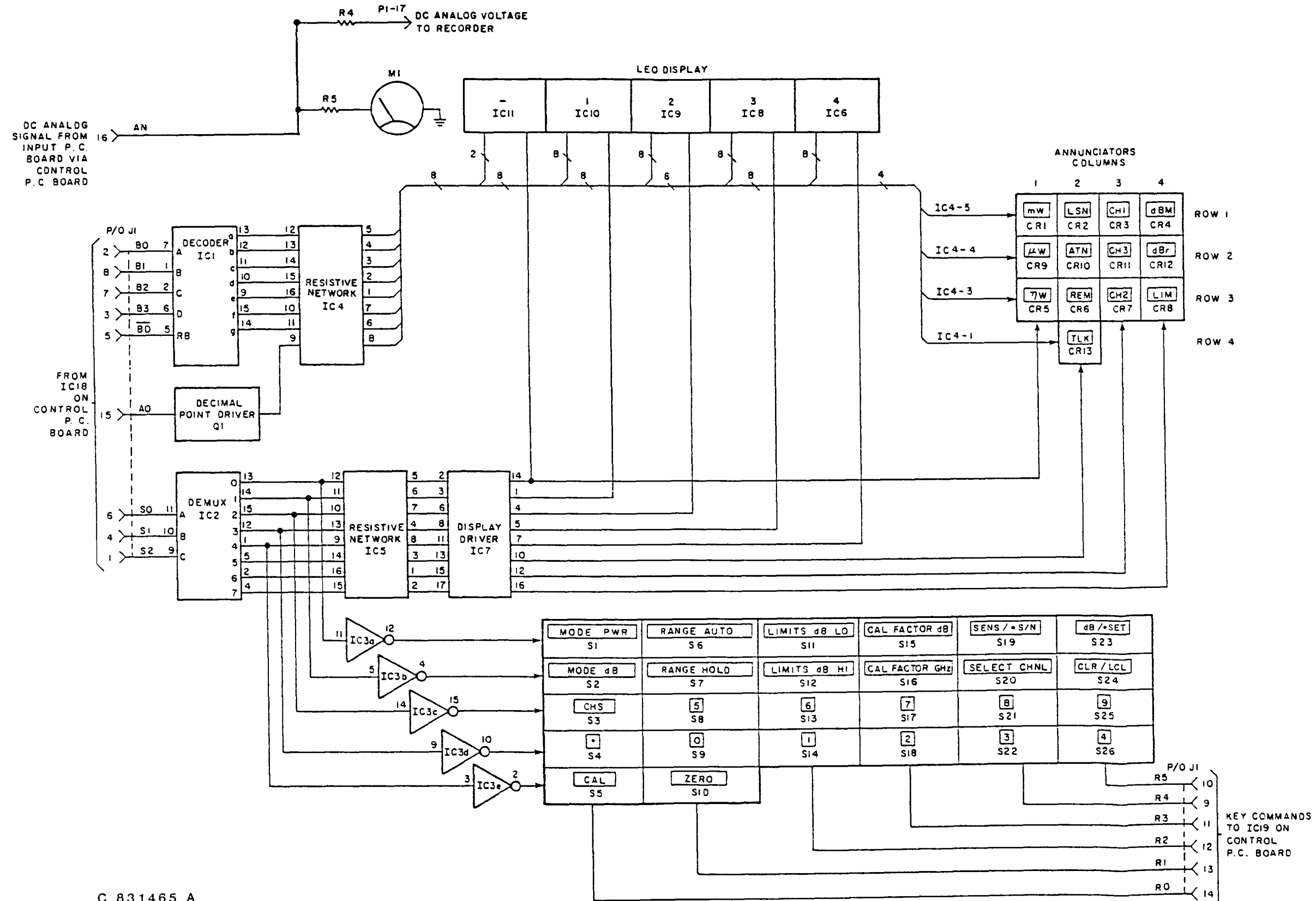

C 831465 A

Figure 4-5 Display P.C. Board, Detailed Block Diagram

4-42. The circuits on the calibrator printed circuit board are used to develop a 1 mW reference power level with a 50-ohm source resistance. This reference level can be used for automatic calibration of the instrument.

4-43. The reference signal is generated by transistor oscillator Q1, which operates at a frequency of approximately 50 MHz. An automatic leveling circuit is used to maintain a constant reference power level. Leveling is achieved by rectifying the oscillator output signal in the signal level detector circuit, and comparing the resulting DC voltage with a stable DC voltage developed by voltage reference IC1. The difference voltage is amplified by operational amplifier A1, and the output level from the operational amplifier controls a varactor in a capacitive divider that determines the drive to the oscillator. The output of the operational amplifier adjusts the varactor effective capacitance as required to adjust the drive to the oscillator in the direction and amount required to maintain a constant output level. A second capacitive divider at the output of the oscillator divides the oscillator output signal and tends to provide some isolation from the load. Because the source impedance of this divider is low, a 50-ohm series resistor is used to establish the desired 50-ohm source resistance. The output reference power level signal is available at the front-panel POWER REF connector.

4-44. DETAILED THEORY OF OPERATION, POWER SUPPLY P.C. BOARD.

(See Figure 4-7.)

4-45. The power supply printed circuit board performs the following functions:

a. Converts 100, 120, 220, or 240 volt 50 to 400 Hz, ac line power to -5, +5, +5.2, +15, and -15 volts dc for system operation.

b. Generates a power-up signal for the microprocessor when supply voltages reach the proper values for system operation.

c. Activates an interrupt signal to the microprocessor when supply voltages drop to levels too low for reliable operation.

4-46. Input ac line power is supplied to the primary of power transformer T1 on the main chassis through fuse F1, line switch S1, and a line voltage selector switch.

4-47. Power transformer T1 steps down the ac line voltage to two secondary windings. These voltages are rectified by bridge rectifiers CR1 and CR2. The dc voltage supplied by CR1 is filtered by C1 and C2 and drives regulators IC2 and IC3 which develop +15 and -15 volts, respectively. The regulated -15 volt supply also drives regulator IC5 to develop the -5 volt supply.

4-48. The dc voltage developed from CR2 is filtered by C3 and drives regulator IC4 to produce +5.2 volts. R5 provides adjustment for the +5.2 volt supply.

4-49. The unregulated +15 volt supply also drives regulator IC1 to produce +5 volts to power A1, IC6, and generate a voltage reference at the junction of R7 and R8.

4-50. The output voltage of the +5.2-volt regulated DC supply is monitored by comparator A1a to develop a power-up signal on turn-on and an interrupt signal under undervoltage or power-down conditions. When the instrument is turned on, comparator A1a develops a positive output pulse when the output of the +5.2-volt regulated supply rises to a value approximately 150 mV below the nominal output voltage; the exact power-up signal point is adjustable by means of potentiometer R11. The positive output pulse of comparator A1a clocks flip-flop IC6 to deactivate signal RESET to the microprocessor on the control printed circuit board. If the output voltage of the +5.2-volt regulated supply should drop below the reliable usable level during operation of the instrument and during instrument shut-down comparator A1a switches its output level to a logic low, thereby activating signal NMI to the microprocessor. The microprocessor activates signal HALT, which resets flip-flop IC6, thereby latching signal RESET low to ensure resetting of the microprocessor to the start of the program.

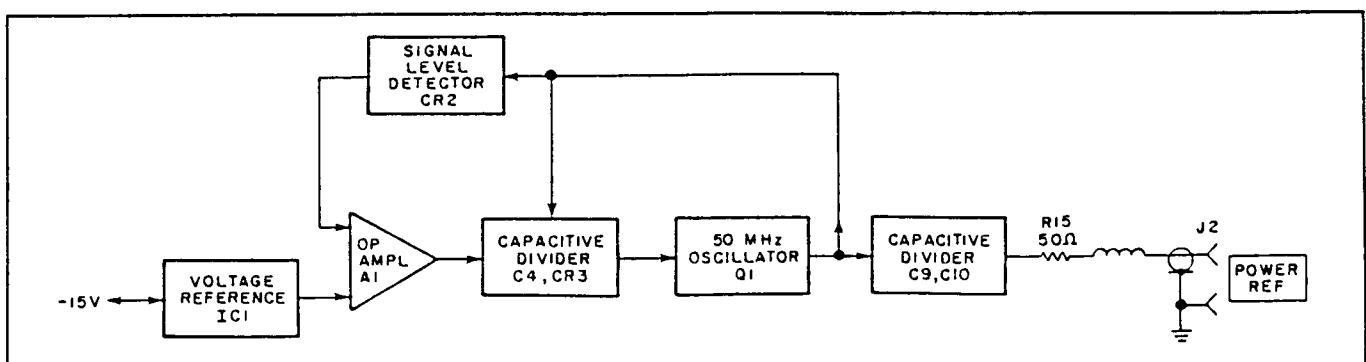
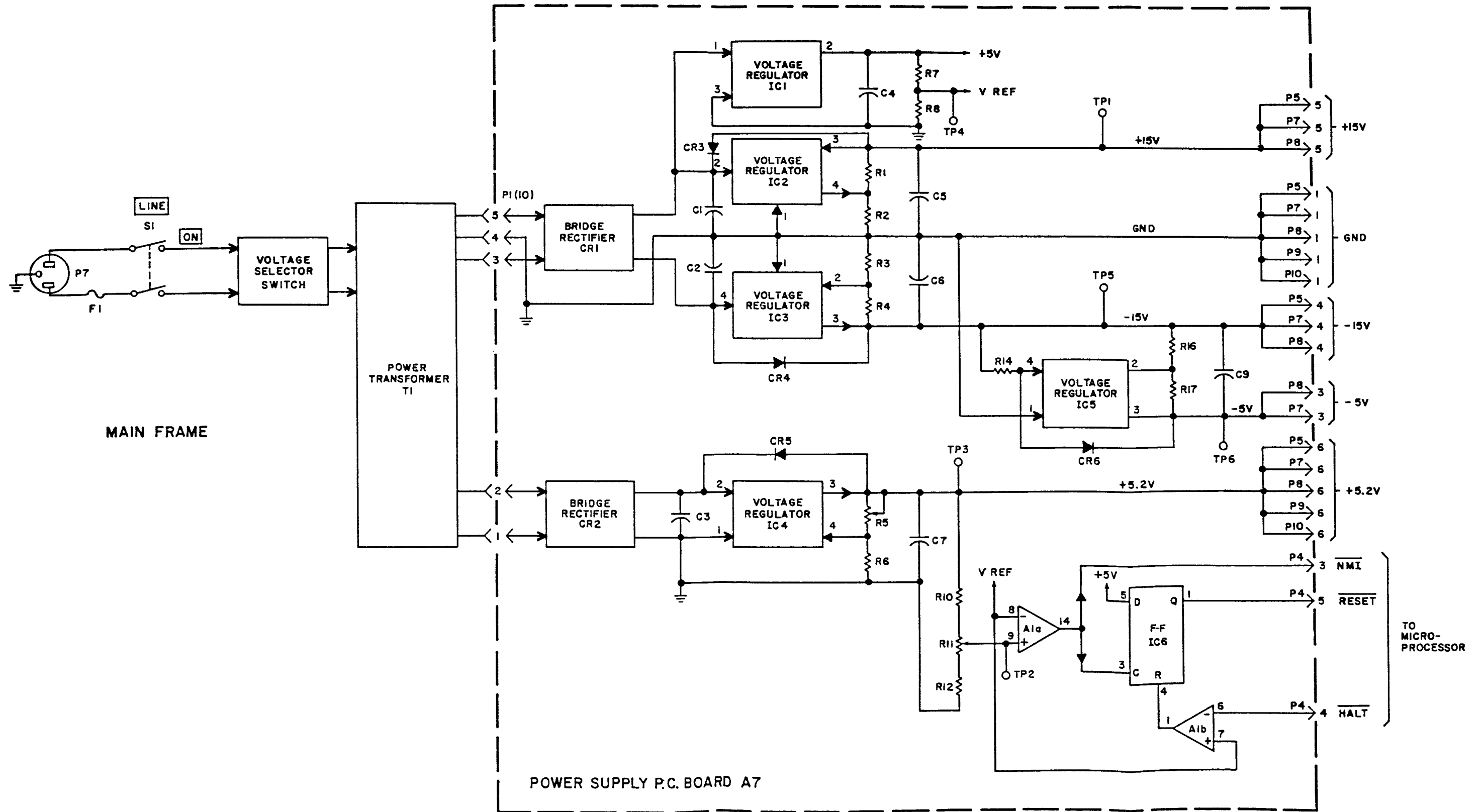

Figure 4-6 Power Reference P.C. Board. Detailed Block Diagram



C831453A

Figure 4-7 Power Supply P.C. Board,
Detailed Block Diagram

SECTION V MAINTENANCE

5-1. INTRODUCTION

5-2. This section contains maintenance instructions for the instrument. Included are a list of required test equipment, trouble localization procedures, instrument adjustment and sensor calibration procedures. Minimum performance checks are included in Section III; these checks should be performed whenever there is any doubt about instrument performance.

5-3. SAFETY REQUIREMENTS.

5-4. Although this instrument has been designed in accordance with international safety standards, general safety precautions must be observed during all phases of operation, service and repair of the instrument. Failure to comply with the precautions listed in the Safety Summary at the front of this manual or with specific warnings given throughout this manual could result in serious injury or death. Service and adjustments should be performed only by qualified service personnel.

5-5. TEST EQUIPMENT REQUIRED

5-6. Table 5-1 lists test equipment required for maintenance of the instrument. Test equipment of equal capability may be substituted for any listed item except the model 5004A signature analyzer (unless it is known that the substitute signature analyzer agrees completely with the model 5004A) and the model 2500 range calibrator.

NOTE

A Diagnostic ROM Kit, P/N 961003 is available for use in troubleshooting the Instrument. The following Two Calibration Data Cartridges are available for use with the Instrument: P/N 961008-1 (for use with the HP 9825A) and P/N 961008-2 (for use with the HP 85B). The Calibration Data Cartridge can be used for testing the GPIB, printing out the contents of non-volatile memory, and DC and AC calibration. Instructions are included with the kit and Data Cartridges.

5-7. TROUBLESHOOTING CONCEPT.

5-8. The instrument employs both analog and digital circuitry. The digital portion uses a microprocessor in a bus-oriented system. DC and AC measuring instrument such as voltmeters and oscilloscopes have been the traditional test instruments for electronic instrument maintenance; however, in a microprocessor-based bus-oriented system, such test equipment, while still useful

and necessary, leaves much to be desired. With such test equipment alone, troubleshooting in a bus-oriented system is extremely tedious and time-consuming, if not impossible. A new technique called signature analysis has been devised to deal with microprocessor-based systems, and the troubleshooting procedures in this manual are based on signature analysis techniques.

5-9. SIGNATURE ANALYSIS.

5-10. A complete discussion of signature analysis is beyond the scope of this manual; however, a brief discussion will aid in maintenance of the instrument. Long, complex data streams are present in microprocessor bus-oriented systems. In signature analysis, with the system operating at normal speed, these data streams are compressed into concise, easy to interpret readouts (signatures) measured at pertinent nodes. By choosing or generating appropriate measuring periods or windows, these signatures become unique; one and only one signature occurs at each node if operation is normal. Using signature analysis, it is possible to proceed through the instrument in an orderly fashion until a faulty signature is obtained. Generally, at this point, it is possible to identify one component as the most probable cause of the malfunction.

TABLE 5-1. TEST EQUIPMENT LIST

Nomenclature	Model No.
Digital Multimeter	Data Precision 1450
Oscilloscope	Hewlett-Packard 1740A
Power Meter Calibrator	Boonton Electronics 25A
Signature Analyzer	Hewlett-Packard 5004A
Calibration Data Cartridges	Boonton Electronics
For use with:	
HP 9825A	P/N 961008-1
HP 85B	P/N 961008-2
Diagnostic ROM Kit	P/N 961003
Range Calibrator	Boonton Electronics 2500
Milliwatt Test Set	W & G EMP-1
VOM	Simpson 260 or equivalent
General Purpose Amplifier 10 dB*	Mini-Circuits ZHL-3A (N Connectors)
*Requires 24 VDC @ .6 A Pwr Supply	
50 ohm Attenuator	Midwest Microwave #389 or Weinschel Mod 2
Attenuator	HP Model 355C or equivalent

Section V Maintenance

5-11. Signature analysis checks are of two basic types: "free-running" and "stimulated" or programmed. In free-running checks, the data bus between the microprocessor and the system is opened, and an instruction that will cause the microprocessor to free-run is forced. The microprocessor then runs through its address field repeatedly. Free-running checks may be used to check the following:

- a. Microprocessor address output
- b. Memory select decoding
- c. I/O select decoding
- d. ROM program

5-12. In the stimulated mode, the data bus between the microprocessor and system bus is left intact, and programs provided in a special ROM are invoked to conduct the desired tests. In this instrument, the stimulated mode is used to check the following:

- a. RAM operation
- b. Display functions and scanning
- c. Keyboard
- d. I/O ports

5-13. In this instrument, programmed signature analysis tests are activated by setting a bit switch, located at the rear of the control board, to the number associated with the particular test. In using signature analysis, the free-running tests should be performed first to ascertain that the microprocessor is putting out a normal address field, that the memory and I/O decoding is correct, and that the ROM contents are normal.

5-14. The signature analysis technique is applicable only to the digital section of the instrument. Some sections of the instrument employ both analog and digital circuits. The input module, for example, receives a DC analog signal and amplifies the analog signal before converting it to a digital signal. The power supply uses both digital and analog circuitry to develop the voltages necessary for instrument operation. The discussion of these hybrid sections in Section IV of this manual will be helpful in maintenance and servicing.

5-15. TROUBLE LOCALIZATION.

5-16. Gaining Access To Internal Components. To gain access to internal components of the instrument, remove the top and bottom covers by removing the securing screws at the rear of each cover and then sliding the cover to the rear. Figure 5-1 shows the location of all major assemblies. To gain access to these assemblies, proceed as follows:

a. **Input Module.** To gain access to the input module, remove four screws (one in each corner) and lift off the cover.

b. **Display Module.** To gain access to the display module, remove the top and bottom covers, remove the four

screws that secure the front top and bottom trim strips, and remove the top and bottom trim strips and front panels.

c. **Power Reference.** The power reference is secured to the front subpanel with two screws entering from the rear. To gain access to the power reference, follow the same procedure as for the display module.

5-17. Visual Inspection. With the instrument covers removed, inspect all assemblies for foreign material, unseated integrated circuits, transistors or connectors, for broken leads, scorched components, loose screws, and other evidence of electrical or mechanical malfunction.

5-18. Use of Block Diagrams. By studying the detailed theory of operation in Section IV together with the associated block diagrams, it may be possible to isolate the cause of an instrument malfunction to a particular block.

5-19. Systematic Troubleshooting. If visual inspection and block diagram analysis do not localize the source of a malfunction, proceed with module troubleshooting as follows:

a. **Power Supply.** With normal input power applied to the instrument, check the power supply output voltages at each module power connector. Correct power supply voltages are shown on the applicable schematic diagrams. If an abnormal voltage is encountered, disconnect the module connector from the module and note whether the power supply output voltage becomes normal; if it does, the problem probably is not in the power supply. If, on the other hand, the abnormal voltage condition remains, work backward through the power supply circuits, comparing voltages with those shown in Figure 7-7. By analyzing abnormal indications, it should be possible to localize the problem to one component in the power supply.

b. **Input Module.** With a 2.51 mW signal applied to the power sensor, compare waveforms and voltages with those shown in Figure 5-2. Correct indications will essentially eliminate the input module as the source of an instrument malfunction; however, incorrect indications will not necessarily localize the problem to the input module because the input module depends on proper operation of the control module for such functions as ranging, analog-to-digital conversion, and recorder and meter output. If incorrect indications are obtained, localization of the problem using the oscilloscope and digital multimeter may be a long and tedious process; a simpler approach may be to proceed with signature analysis.

c. **Display Module.** Proper operation of the display module is generally self-evident. Incorrect operation does not necessarily mean that the problem is in the display module; the control module may be malfunctioning. The simplest and quickest way to check the display module is

to perform the visual and signature analysis checks specified in paragraph 5-22.

d. **Control Module.** If normal indications are obtained in checking the power supply, input, and display modules, the problem must be in the control module; however, it is very unlikely that this situation will occur because it is virtually impossible for the input and display modules to operate properly if the control module is malfunctioning. Signature analysis is the best way to localize a problem in the control module.

5-20. SIGNATURE ANALYSIS FREE-RUNNING TEST PROCEDURES.

5-21. To make free-running signature analysis tests, proceed as follows:

CAUTION

Make sure that power is off before attempting to perform steps a, b, and f of the following procedure. Failure to observe this caution may result in the loss or destruction of data stored in the non-volatile RAM.

NOTE

Prior to any signature analysis checks, note and record bit switch (Figures 5-1 and 5-3) settings. Restore these switch settings upon completion of the signature analysis tests.

a. **With power off**, remove the data bus connector P1 on the control board from socket J1 adjacent to J2, and remove the data bus connector P1 on the control board from socket J1 adjacent to IC2 and disconnect jumper from connector J5. (See Figure 7-5.) Do not remove any of the control board PROMs.

b. Detailed information for each of the free-running tests is provided in Tables 5-2 through 5-7. For each check, set the signature analyzer controls and make signature analyzer connections as specified in the applicable table.

NOTE

For instruments containing PROMs with codes differing from those referred to in the various signature analysis tables contact the Boonton Service Department for correct signatures.

c. After setting and connecting the signature analyzer, apply power to the instrument, touch the signature analyzer probe to the specified measurement points, and compare the signature obtained on the signature analyzer with that specified in the table. An incorrect signature is evidence of malfunction.

d. If an incorrect signature is noted, try replacing the integrated circuit(s) most intimately associated with the point at which the incorrect signature was obtained. For example: an incorrect signature in the address field would point to integrated circuit IC3 on the control board, but the problem could be caused by any other integrated circuit or component tied to that address line.

e. A signature of 0000 is obtained with the signature analyzer probe connected to common (ground). Some other items which will produce this signature are:

1. A node stuck at zero
2. A node at the signature analyzer clock frequency.

f. A signature of 755U is obtained with the signature analyzer probe connected to +5 volts. Some other items that will produce this signature are:

1. A node stuck at logic 1
2. Any signal with a specific relationship to the clock signal; if the clock signal is signal RD from the microprocessor, signals IORQ, WR, and RFSH are examples of signals that will produce this signature.

g. Upon completion of the free-running checks, *turn power off*. Then, reinstall data bus connector P1 in socket J1 on the control board and reinstall jumper at connector J5.

NOTE

If programmed tests are to be performed, leave jumper disconnected from connector J5.

5-22. SIGNATURE ANALYSIS PROGRAMMED TEST PROCEDURES.

NOTE

Perform the free-running signature analysis tests before proceeding with programmed tests.

5-23. Use the following general procedure for each of the specified programmed signature analysis tests:

NOTE

A Boonton Electronics diagnostic PROM is required for the programmed signature analysis tests. The diagnostic PROM is part of the 961004 Test Kit.

- a. Turn off input power to the instrument.
- b. Remove ROM IC6 and IC7 from its socket on the control board, and remove ROMs IC6 and IC7 from its socket on the interface board (if option -01 is installed), (See Figure 7-5 and A-2).
- c. Install the diagnostic PROM in place of ROM IC6 observing pin 1 orientation.

Section V
Maintenance

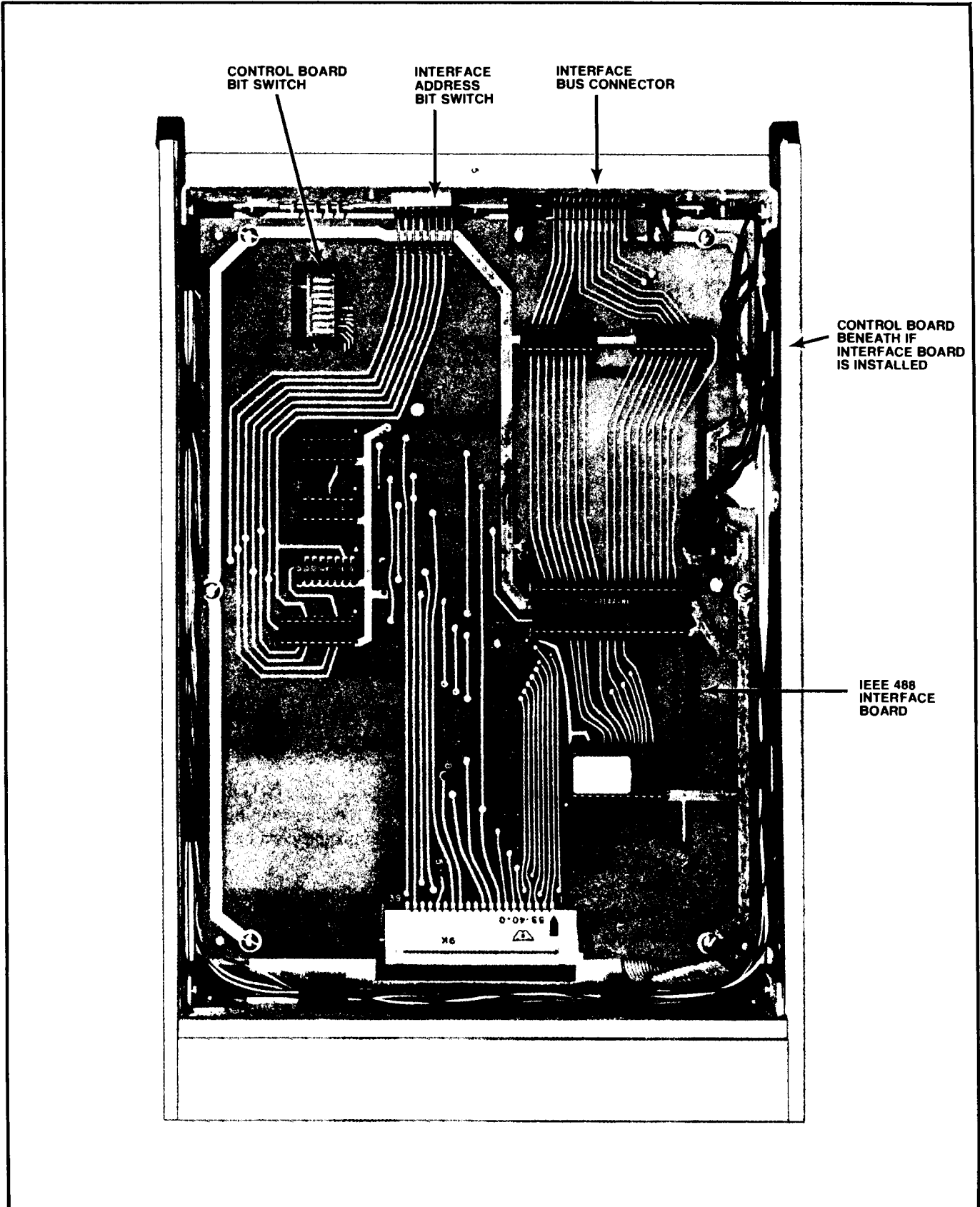

Figure 5-1 Location of Major Assemblies (Sheet 1 of 2)

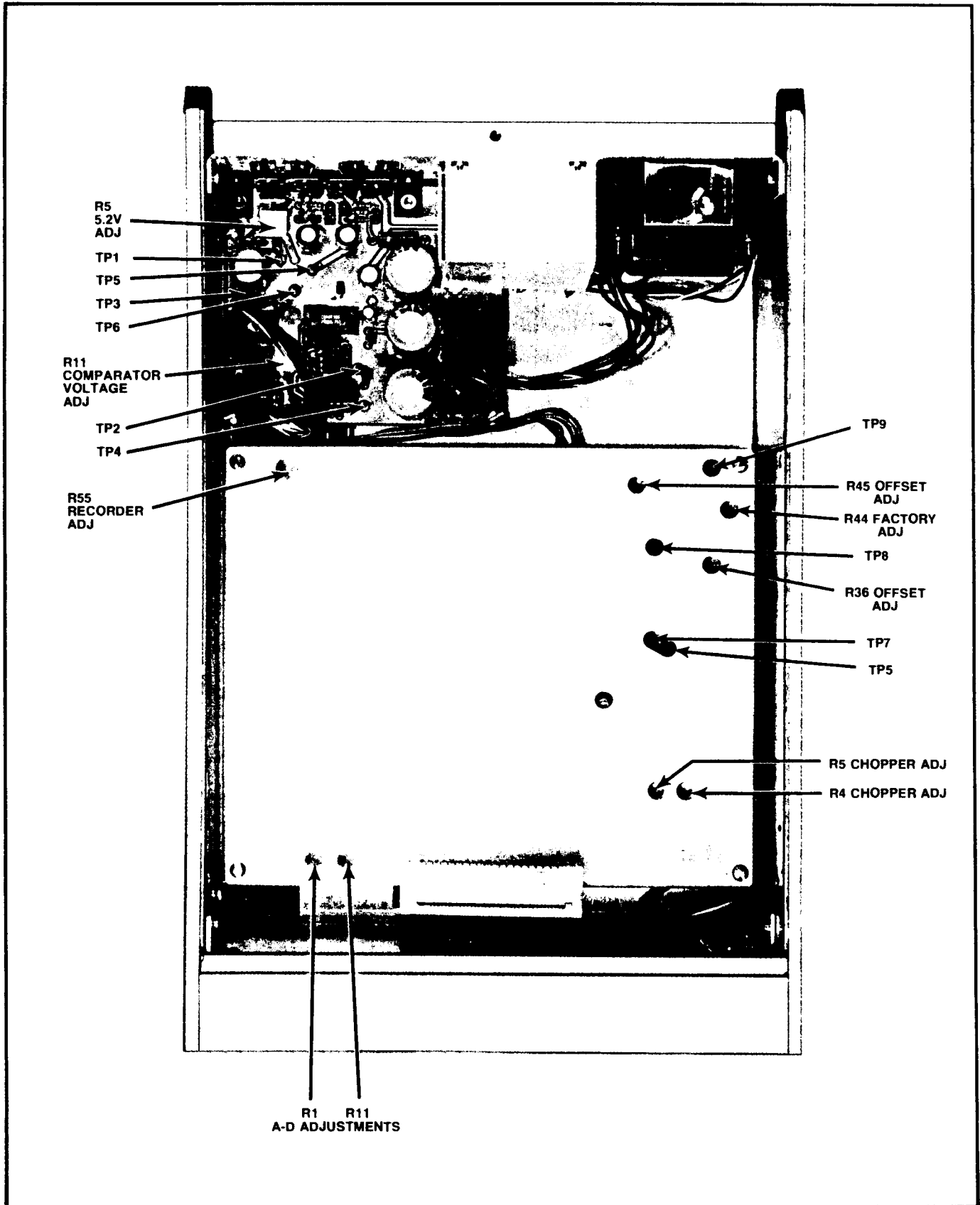
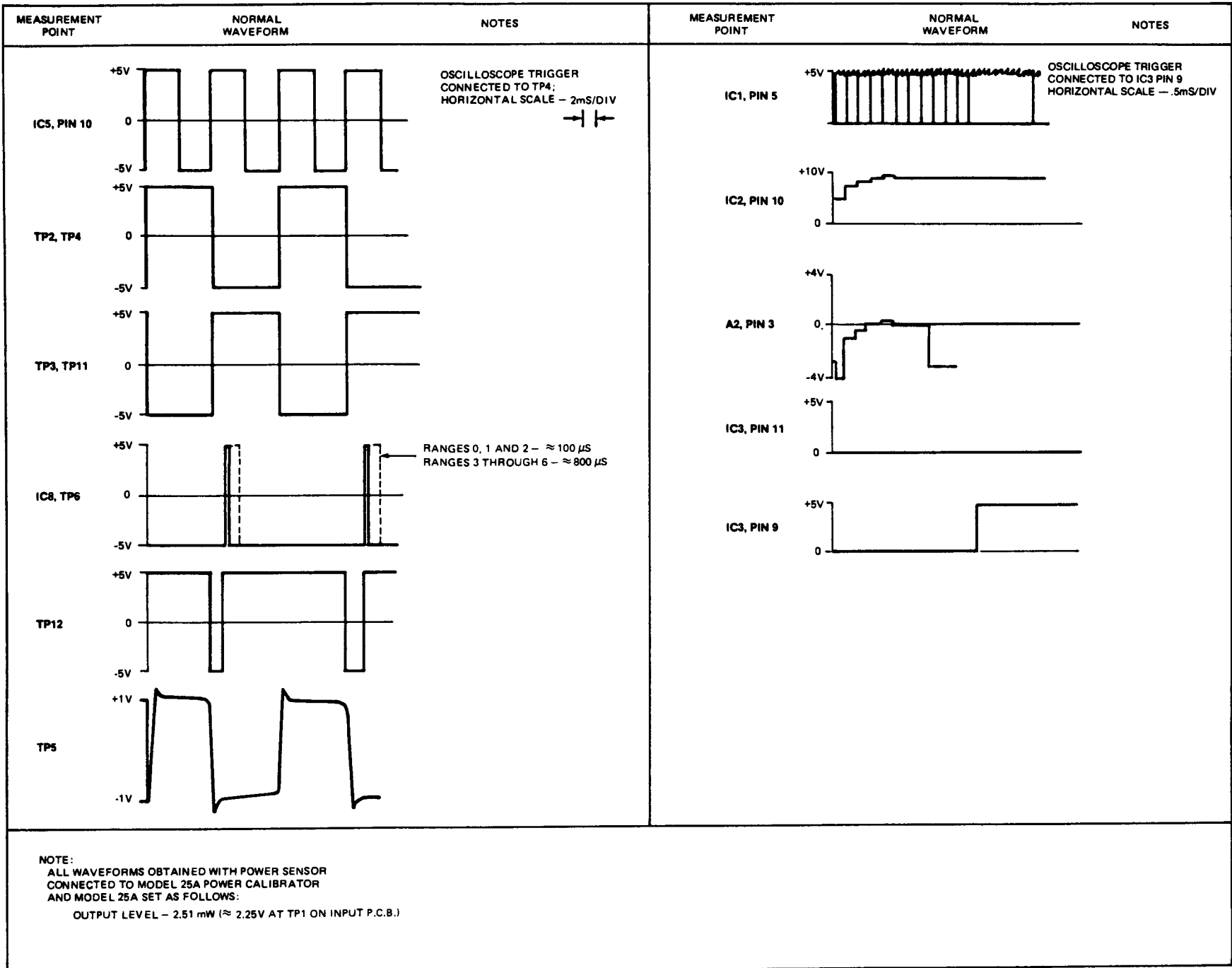
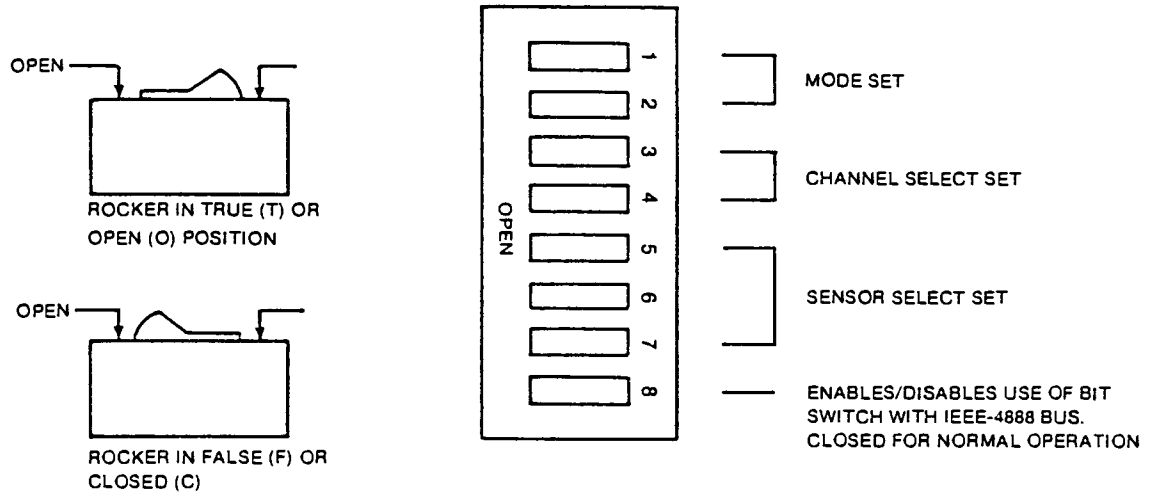

Figure 5-1 Location of Major Assemblies (Sheet 2 of 2)

Figure 5-2 Input P.C. Board: Voltage and Waveform Data





Switch Setting								Comment
8	7	6	5	4	3	2	1	
ALWAYS CLOSED	NOT USED							
						C	C	Operate Mode
						C	O	Calibrate Mode 1 (DC Cal.)
						O	C	Calibrate Mode 2 (AC Cal.)
					C			One Channel Operation
					O			Two Channel Operation
		C	C	C				One Sensor Capability
		C	C	O				Two Sensor Capability
		C	O	C				Three Sensor Capability
		C	O	O				Four Sensor Capability
		O	C	C				Five Sensor Capability
		O	C	O				Six Sensor Capability
		O	O	C				Seven Sensor Capability
		O	O	O				Eight Sensor Capability
O								
O	O	O	O	AS REQ	O	O	Sealed System Operation	

Figure 5-3 Control Board Bit Switch Settings

TABLE 5-2. CONTROL BOARD ADDRESS FIELD TEST*

Signature Analyzer			Bit Switch**								Item	Measurement Point	Signature
Function	Switch Setting	Connection Point	1	2	3	4	5	6	7	8			
START	┌ └ └	TP1	Any setting									Common	0000
STOP		TP1										+5V	755U
CLK		TP5									A0	IC3, pin 30	H335
		A1									IC3, pin 31	C113	
		A2									IC3, pin 32	7050	
		A3									IC3, pin 33	0772	
		A4									IC3, pin 34	C4C3	
		A5									IC3, pin 35	AA08	
		A6									IC3, pin 36	7211	
		A7									IC3, pin 37	A3C1	
		A8									IC3, pin 38	7707	
		A9									IC3, pin 39	577A	
		A10									IC3, pin 40	HH86	
		A11									IC3, pin 1	89F1	
		A12									IC3, pin 2	AC99	
		A13									IC3, pin 3	PCF3	
		A14									IC3, pin 4	1180	
		A15	IC3, pin 5	755U									

*This test checks the output of the proper address field by CPU IC3; however, any item connected to an address line could be responsible for an incorrect signature on that line.

**O = open

TABLE 5-3. CONTROL BOARD MEMORY DECODING TEST*

Signature Analyzer			Bit Switch**								Item	Measurement Point	Signature
Function	Switch Setting	Connection Point	1	2	3	4	5	6	7	8			
START	┌ └ └	TP1	Any setting									Common	0000
STOP		TP1										+5V	755U
CLK		TP5									$\overline{CS0}$	IC4, pin 1	FU4U
		$\overline{CS1}$									IC4, pin 2	A207	
		$\overline{CS2}$									IC4, pin 3	H6A3	
		$\overline{CS3}$	IC4, pin 4	HU34									

*This test checks decoding for selection of memory integrated circuits.

**O = open

TABLE 5-4. CONTROL BOARD I/O DECODING TEST*

Signature Analyzer			Bit Switch**								Measurement		
Function	Switch Setting	Connection Point	1	2	3	4	5	6	7	8	Item	Point	Signature
START	┌ └	TP1	Any setting									Common	0000
STOP		TP1										+5V	755U
CLK		TP5										$\overline{CS0}$	IC14, pin 1
											$\overline{CS1}$	IC14, pin 2	7375
											$\overline{CS2}$	IC14, pin 3	253H
											$\overline{CS3}$	IC14, pin 4	8059
											$\overline{CS4}$	IC14, pin 5	PAOU

*This test checks decoding for selection of I/O integrated circuits.

**O = open

TABLE 5-5. CONTROL BOARD ROM 0 TEST*

Signature Analyzer			Bit Switch								Measurement		
Function	Switch Setting	Connection Point	1	2	3	4	5	6	7	8	Item	Point	Signature
START	┌ └	TP7	Any setting									Common	0000
STOP		TP7										+5V	826P
CLK		TP5										D0	IC6, pin 9
											D1	IC6, pin 10	2265
											D2	IC6, pin 11	AH7A
											D3	IC6, pin 13	6341
											D4	IC6, pin 14	C0F3
											D5	IC6, pin 15	7C35
											D6	IC6, pin 16	F152
											D7	IC6, pin 17	U120

*This test checks the program content of ROM 0, for software code 314BC.

TABLE 5-6. CONTROL BOARD ROM 1 TEST*

Signature Analyzer			Bit Switch								Measurement		
Function	Switch Setting	Connection Point	1	2	3	4	5	6	7	8	Item	Point	Signature
START	┌ └	TP19	Any Setting									Common	0000
STOP		TP19										+5V	826P
CLK		TP5										D0	IC7, pin 9
											D1	IC7, pin 10	SU29
											D2	IC7, pin 11	112P
											D3	IC7, pin 13	FUU2
											D4	IC7, pin 14	9A15
											D5	IC7, pin 15	AP12
											D6	IC7, pin 16	916P
											D7	IC7, pin 17	1967

*This test checks the program content of ROM 1, for software code 365BC.

TABLE 5-7. INTERFACE BOARD ROM 2 TEST*

Function	Signature Analyzer		Bit Switch								Item	Measurement Point**	Signature	
	Switch Setting	Connection Point	1	2	3	4	5	6	7	8				
START		TP18	Any setting									Common +5V	0000 826P	
STOP		TP18												
CLK		TP5												
												D0	IC1, pin 9	504F
												D1	IC1, pin 10	A820
												D2	IC1, pin 11	P036
												D3	IC1, pin 13	90H3
												D4	IC1, pin 14	PC1A
												D5	IC1, pin 15	20AC
												D6	IC1, pin 16	PF5C
												D7	IC1, pin 17	721H

*This test checks the program content of ROM 2, for software code 322BC.

**Signature analyzer connection points are on control board; measurement points are on interface board.

d. Check to see that data bus connector P1 on the control board is installed in socket J1, and that jumper P5 on the control board is connected to connector J5.

e. Turn on input power to the instrument.

f. Perform the specific test procedures provided in Tables 5-7 through 5-22. For each of the programmed signature analysis tests, make signature analyzer connections and switch settings as listed in the appropriate table. Then, set the bit switch on the control board as specified.

Connect the signature analyzer probe to the specified measurement points, and compare the signatures obtained on the signature analyzer with those listed in the table.

g. Note that in each signature analysis test the signature analyzer probe is first checked on common (ground) and then on +5 volts. If the specified signatures are not obtained for these checks, do not proceed further; subsequent signatures cannot possibly be correct. Recheck all signature analyzer connections and switch settings.

h. Both visual and signature analysis tests are provided for the display and keyboard of the instrument. The visual check should be made first because it is fast and simple; if the visual check is satisfactory, the signature analysis test may be omitted.

i. If an incorrect signature is obtained at any point, replace the integrated circuit (or other active device) most intimately associated with the node at which the incorrect signature is obtained. All integrated circuits and transistors in the instrument are socket-mounted for easy removal and replacement. If the signature is still incorrect after all active devices have been checked, all passive devices connected to that node should be suspect.

j. Upon completion of all tests, disconnect all power to the instrument. Replace ROM U1 on the interface board the -01A option is installed, or replace the -01B board, if installed. Remove the diagnostic PROM from the control board and replace ROM IC6 and IC7.

k. Restore the bit switch (Figure 5-4) to the settings recorded at the start of signature analysis tests.

5-24. NON-VOLATILE RAM CIRCUIT TESTS.

5-25. Non-Volatile RAM Test. To test non-volatile RAM IC8, proceed as follows:

CAUTION

This test will destroy and overwrite instrument data stored in the non-volatile RAM, necessitating reloading of data. This test should be made as a last resort only, or if it has been determined that stored instrument data has already been lost or is faulty.

NOTE

Leave the Boonton Electronics diagnostic ROM installed on the control board as for the programmed signature analysis tests. Make sure that jumper P5 on the control board is connected to connector J5.

a. With power applied to the instrument, set all eight segments of the bit switch on the control board to the open position.

b. Observe the instrument LED display. The LED display should provide an error indication eccc initially.

TABLE 5-8 CONTROL BOARD 4ABIO TEST*

Function	Signature Analyzer		Bit Switch**								Item	Measurement Point	Signature
	Switch Setting	Connection Point	1	2	3	4	5	6	7	8			
START	┌ └	TP6											
STOP		TP6											
CLK		TP5											
			C	C	C	C	C	C	C	C		Common	0000
												+5V	0000
											PB0	J3, pin 1	0000
											PB1	J3, pin 2	0000
											PB2	J3, pin 3	0000
											PB3	J3, pin 4	0000
											PB4	J3, pin 5	0000
											PB5	J3, pin 6	0000
											PB6	J3, pin 7	0000
											PB7	J3, pin 8	0000
			O	C	C	C	C	C	C	C	PB0	J3, pin 1	4F7C
			C	O	C	C	C	C	C	C	PB1	J3, pin 2	4F7C
			C	C	O	C	C	C	C	C	PB2	J3, pin 3	4F7C
			C	C	C	O	C	C	C	C	PB3	J3, pin 4	4F7C
			C	C	C	C	O	C	C	C	PB4	J3, pin 5	4F7C
			C	C	C	C	C	O	C	C	PB5	J3, pin 6	4F7C
			C	C	C	C	C	C	O	C	PB6	J3, pin 7	4F7C
			C	C	C	C	C	C	C	O	PB7	J3, pin 8	4F7C

*This test checks operation of ports A and B of the control module I/O port; the function of the bit switch is checked collaterally.

**O = open; C = closed

TABLE 5-9 CONTROL BOARD 4CIO TEST*

Function	Signature Analyzer		Bit Switch**								Item	Measurement Point	Signature
	Switch Setting	Connection Point	1	2	3	4	5	6	7	8			
START	┌ └	TP6											
STOP		TP6											
CLK		TP5											
												Common	0000
												+5V	7C88
			O	C	C	C	C	C	C	O	PC0	IC16, pin 14	5437
											PC1	IC16, pin 15	CCA9
											PC2	IC16, pin 16	1788
											PC3	IC16, pin 17	7C88

*This test checks the operation of part of port C of the control board I/O port.

**O = open; C = closed

TABLE 5-10 CONTROL BOARD 4DIO TEST*

Function	Signature Analyzer		Bit Switch**								Item	Measurement Point	Signature
	Switch Setting	Connection Point	1	2	3	4	5	6	7	8			
START	┌ └	TP6											
STOP		TP6											
CLK		TP5											
												Common	0000
												+5V	58UA
			C	O	C	C	C	C	C	O	PC4	IC16, pin 13	0000 ^①
											PC4	IC16, pin 13	C35P ^②

*This test checks the operation of part of port C on the control board I/O port.

**O = open; C = closed

① Line voltage = 120 volts

② Line voltage = 90 volts

Section V
Maintenance

TABLE 5-11 DISPLAY VISUAL TEST

Bit Switch*								Instrument Display
1	2	3	4	5	6	7	8	
O	O	C	O	O	C	C	O	In succession: All zeros All ones through all nines All decimal points All left-most annunciators All left-most-1 annunciators All left-most-2 annunciators All right-most annunciators and - sign Repeat of the above

NOTE: If this visual check produces satisfactory results, there is no need to perform the associated signature analysis check.

* O = open; C = closed

TABLE 5-12 CONTROL BOARD DISPLAY TEST*

Signature Analyzer			Bit Switch**					Measurement	Signature				
Function	Switch Setting	Connection Point	1	2	3	4	5	6	7	8	Item	Point	Signature
START		TP6										Common	0000
STOP		TP6										+5V	F72F
CLK		TP5											
			O	O	C	O	O	C	C	O	D0	IC3, pin 14	94F8
											D1	IC3, pin 15	PH9U
											D2	IC3, pin 12	83FF
											D3	IC3, pin 8	4A1H
											D4	IC3, pin 7	H1P5
											D5	IC3, pin 9	F3A7
											D6	IC3, pin 10	P85F
											D7	IC3, pin 13	5536

*This test checks output of digital information to the display. The signature analysis gate in this test is quite lengthy (approximately 8 seconds); hold the signature analyzer probe on each test point for at least one complete window, approximately 20 seconds.

**O = open; C = closed

TABLE 5-13 CONTROL BOARD DISPLAY SCAN TEST*

Signature Analyzer			Bit Switch**					Measurement	Signature				
Function	Switch Setting	Connection Point	1	2	3	4	5	6	7	8	Item	Point	Signature
START		TP4										Common	0000
STOP		TP4										+5V	000U
CLK		TP8											
			O	O	C	O	O	C	C	O	S0	IC18, pin 32	0000
											S1	IC18, pin 33	0005
											S2	IC18, pin 34	0003
											S3	IC18, pin 35	000U

*This test checks the control board display I/O chip for output of encoded scan data.

**O = open; C = closed



TABLE 5-14 KEYBOARD VISUAL TEST*

Bit Switch**								Press Keyboard	Instrument Display
1	2	3	4	5	6	7	8	Key	
C	C	O	C	C	C	C	O	MODE PWR	0
								RANGE AUTO	1
								LIMITS LO	2
								CAL FACTOR dB	3
								SELECT SENS	4
								dB REF LEVEL dB	5
								MODE dB	8
								RANGE HOLD	9
								LIMITS HI	10
								CAL FACTOR GH-	11
								SELECT CHNL	12
								CLR	13
								CHS	16
								5	17
								6	18
								7	19
								8	20
								9	21
									24
								0	25
								1	26
								2	27
								3	28
								4	29
								CAL	32
								ZERO	33

*This test is partly keyboard and partly control board because the I/O chip (IC18) for the display board resides on the control board.

**O = open; C = closed

TABLE 5-15 CONTROL BOARD RAM TEST*

Function	Signature Analyzer		Bit Switch**								Item	Measurement	
	Switch Setting	Connection Point	1	2	3	4	5	6	7	8		Point	Signature
START		TP6											
STOP		TP6											
CLK		TP5											
			O	C	O	C	C	C	C	O	PB0	Common	0000
												+5V	2915
											PB1	J3, pin 1	5PPA
											PB2	J3, pin 2	77UU
											PB3	J3, pin 3	5PPA
											PB4	J3, pin 4	77UU
											PB5	J3, pin 5	5PPA
											PB6	J3, pin 6	77UU
											PB7	J3, pin 7	5PPA
												J3, pin 8	77UU

*This test writes bit patterns into each byte of the RAM, reads each byte and outputs it to the test socket at the rear of the control board where it is checked with the signature analyzer probe. While not completely exhaustive, this test will disclose most RAM failures

**O = open; C = closed

Section V
Maintenance

TABLE 5-16 INPUT MODULE, CHANNEL 1 0AIO TEST*

Function	Signature Analyzer		Bit Switch**								Item	Measurement Point	Signature
	Switch Setting	Connection Point***	1	2	3	4	5	6	7	8			
START	┌ └	TP6										Common	0000
STOP		TP6										+5V	876P
CLK		TP5											
			C	O	O	C	C	C	C	O	PA0	IC1, pin 4	485P
											PA1	IC1, pin 3	1A33
											PA2	IC1, pin 2	F85P
											PA3	IC1, pin 1	5H7U
											PA4	IC1, pin 40	OFF1
											PA5	IC1, pin 39	F10C
											PA6	IC1, pin 38	909I
											PA7	IC1, pin 37	4P8I

*This test checks the operation of I/O port A of the input module; correct signatures depend on proper functioning of both the control board and the input module.

**O = open; C = closed

***Signature analyzer connection points are on the control board; measurement points are on input module board.

TABLE 5-17 INPUT MODULE, CHANNEL 1 0BIO TEST*

Function	Signature Analyzer		Bit Switch**								Item	Measurement Point	Signature
	Switch Setting	Connection Point***	1	2	3	4	5	6	7	8			
START	┌ └	TP6										Common	0000
STOP		TP6										+5V	876P
CLK		TP5											
			O	O	O	C	C	C	C	O	PB0	IC1, pin 18	485P
											PB1	IC1, pin 19	1A33
											PB2	IC1, pin 20	F85P
											PB3	IC1, pin 21	5H7U
											PB4	IC1, pin 22	OFF1
											PB5	IC1, pin 23	F10C
											PB6	IC1, pin 24	909I
											PB7	IC1, pin 25	4P8I

*This test checks the operation of I/O port B of the input module; correct signatures depend on proper functioning of both the control board and the input module.

**O = open; C = closed

***Signature analyzer connection points are on the control board; measurement points are on input module board.

TABLE 5-18 INPUT MODULE, CHANNEL 1 0CIO TEST*

Signature Analyzer			Bit Switch**								Measurement		
Function	Switch Setting	Connection Point***	1	2	3	4	5	6	7	8	Item	Point	Signature
START		TP6										Common	0000
STOP		TP6										+5V	5064
CLK		TP5											
			C	C	C	O	C	C	C	O	PC0	IC1, pin 14	6U01
											PC1	IC1, pin 15	671U
											PC2	IC1, pin 16	CFH2
											PC3	IC1, pin 17	121H

*This test checks the operation of part of I/O port C on the input module; correct signatures depend on proper operation of both the input module and the control board.

**O = open; C = closed

***Signature analyzer connection points are on the control board; measurement points are on input module board.

TABLE 5-19 INPUT MODULE, CHANNEL 1 0DIO TEST*

Signature Analyzer			Bit Switch**								Measurement		
Function	Switch Setting	Connection Point***	1	2	3	4	5	6	7	8	Item	Point	Signature
START		TP6										Common	0000
STOP		TP6										+5V	23HC or 5C43
CLK		TP5											
			O	C	C	O	C	C	C	O	PB0	A5J3, pin 1	0000①
											PB0	A5J3, pin 1	7H97②

*This test checks part of I/O port C of the input module for channel 1.

**O = open; C = closed

***Signature analyzer connection points and measurement points are on the control board.

① Signature obtained with range calibrator connected to channel 1 input, and range calibrator set to zero and $R_S = 500k$, or with instrument sensor connected to power REF connector and POWER REF ON switch set to off.

② Signature obtained with range calibrator connected to channel 1 input, and range calibrator set to range 5 and $R_S = 500k$, or with instrument sensor connected to POWER REF connector and POWER REF ON switch set to on.

TABLE 5-20 INPUT MODULE, CHANNEL 2 1AIO TEST*

Signature Analyzer			Bit Switch**								Measurement		
Function	Switch Setting	Connection Point***	1	2	3	4	5	6	7	8	Item	Point	Signature
START		TP6										Common	0000
STOP		TP6										+5V	876P
CLK		TP5											
			O	O	C	O	C	C	C	O	PA0	IC1, pin 4	485P
											PA1	IC1, pin 3	1A33
											PA2	IC1, pin 2	F85P
											PA3	IC1, pin 1	5H7U
											PA4	IC1, pin 40	OFF1
											PA5	IC1, pin 39	FIOC
											PA6	IC1, pin 38	9091
											PA7	IC1, pin 37	4P81

*This test checks the operation of I/O port A on input module 2. Correct signatures depend on the proper operation of both the control board and input module 2.

**O = open; C = closed

***Signature analyzer connection points are on the control board; measurement points are on input module board.

Section V
Maintenance

TABLE 5-21 INPUT MODULE, CHANNEL 2 IBIO TEST*

Function	Signature Analyzer		Bit Switch**								Item	Measurement	
	Switch Setting	Connection Point***	1	2	3	4	5	6	7	8		Point	Signature
START		TP6										Common	0000
STOP		TP6										+5V	876P
CLK		TP5											
			C	C	O	O	C	C	C	O	PB0	IC1, pin 18	485P
											PB1	IC1, pin 19	1A33
											PB2	IC1, pin 20	F85P
											PB3	IC1, pin 21	5H7U
											PB4	IC1, pin 22	OFF1
											PB5	IC1, pin 23	F1OC
											PB6	IC1, pin 24	909I
											PB7	IC1, pin 25	4P8I

*This test checks the operation of I/O port B of input module 2. Correct signatures depend on proper operation of both the control board and input module 2.

**O = open; C = closed

***Signature analyzer connection points are on the control board; measurement points are on input module board.

TABLE 5-22 INPUT MODULE, CHANNEL 2 ICIO TEST*

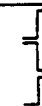
Function	Signature Analyzer		Bit Switch**								Item	Measurement	
	Switch Setting	Connection Point***	1	2	3	4	5	6	7	8		Point	Signature
START		TP6										Common	0000
STOP		TP6										+5V	5064
CLK		TP5											
			O	C	O	O	C	C	C	O	PC0	IC1, pin 14	6UO1
											PC1	IC1, pin 15	671U
											PC2	IC1, pin 16	CFH2
											PC3	IC1, pin 17	121H

*This test checks the operation of part of I/O port C of input module 2. Correct signatures depend upon proper operation of both the control board and input module 2.

**O = open; C = closed

***Signature analyzer connection points are on the control board; measurement points are on input module board.

TABLE 5-23 INPUT MODULE, CHANNEL 2 IDIO TEST*

Function	Signature Analyzer		Bit Switch**								Item	Measurement Point	Signature
	Switch Setting	Connection Point***	1	2	3	4	5	6	7	8			
START	}	TP6										Common +5V A5J3, pin 1 A5J3, pin 1	0000 P951① or 1088 0000① 7H97②
STOP		TP6											
CLK		TP5											
			C	O	O	O	C	C	C	O	PB0 PB0		

*This test checks part of I/O port C of the channel 2 input module.

**O = open; C = closed

***Signature analyzer connection points and measurement points are on the control board.

- ① Signature obtained with range calibrator connected to the channel 2 input, and range calibrator set to zero and $R_s = 500k\Omega$, or with instrument channel 2 sensor connected to POWER REF connector and POWER REF ON switch set to off.
- ② Signature obtained with range calibrator connected to the channel 2 input, and range calibrator set to range 5 and $R_s = 500k\Omega$, or with instrument channel 2 sensor connected to POWER REF connector and POWER REF ON switch set to on.

c. Turn the input power off, then back on. If the non-volatile RAM is operating properly, the instrument LED display will show 1111.

d. Repeat step c several times. The LED display should always show 1111, not the error indication.

e. Upon completion of this test, turn off input power to the instrument, remove the diagnostic ROM from the control board, and install integrated circuits IC5 and IC6 in their sockets on the control board, making certain that the correct pin 1 orientation is observed.

5-26. Non-Volatile RAM Cell Test. To test the non-volatile RAM cell, proceed as follows:

CAUTION

The following test procedure must be adhered to strictly; otherwise, instrument data stored in the non-volatile RAM will be lost. Do not attempt to take measurements other than those specified. Take all necessary precautions to ensure that no terminals are shorted to another terminal or to common (ground).

NOTE

The load imposed on the cell by the non-volatile RAM is 5.25 microamperes or less. With this load, the cell has a rated life of at least 100,000 hours, which is greater than 10 years.

a. Remove the non-volatile RAM cover to gain access to the cell terminals.

b. Connect a digital multimeter between the cell positive terminal and ground, ensuring that the cell is not shorted to ground at any time.

c. Observe the digital multimeter indication: it should be approximately 3 volts with input power to the instrument turned off. If the indication is much lower than 3 volts, replace the cell in accordance with the procedures in paragraph 4-25.

5-27. Non-Volatile RAM Cell Replacement. (See Figure 5-4). The replacement time for the cell is expected to be 10 years from the time of manufacture. This is the shelf life of the cell. If cell replacement is needed, restoration of all instrument calibration data will be required. To replace a defective cell, proceed as follows:

CAUTION

Use care to avoid shorting the leads of the replacement cell. This will cause discharge of the cell and result in reduced cell lifetime.

a. Remove the control printed circuit board from the instrument.

b. Remove the insulating shields from the non-volatile RAM section.

c. Disconnect the positive lead of the defective cell by cutting the lead.

d. Unsolder the defective cell using a low-wattage soldering iron, and remove excess solder from the mounting holes.

Section V
Maintenance

- e. Install the replacement cell, observing cell polarity.
- f. Solder the negative terminal of the cell first. Then, as quickly as possible, solder the positive terminal.
- g. Check the non-volatile RAM current by measuring the voltage across resistor R6. This voltage should be less than 525 microvolts.
- h. Measure the voltage at pin 12 of integrated circuit IC8. This voltage should be approximately 3 volts.
- i. Reassemble the shields on the control printed circuit board, and install the control printed circuit board in the instrument.

5-28. INSTRUMENT ADJUSTMENTS.

5-29. General. Adjustment procedures are provided for the chopper, input, display, power supply and power reference boards. The control board requires no adjustments. For the locations of test points and adjustment controls, refer to the applicable diagrams in Section VII.

5-30. Power Supply Adjustments. With all power connectors in place, the instrument controls set for proper line operation, and with line voltage applied, make power supply adjustments as follows:

- a. Connect the digital voltmeter between TP3 and common. Note the voltage indication; it should be 5.20 ± 0.002 Vdc. Adjust R5 as required to obtain the specified voltage.

- b. Connect the digital voltmeter between HI lead to TP2 and LO lead to TP4. Note the voltage indication; it should be $150 \text{ mV} \pm 10 \text{ mV}$. Adjust R11 for an indication of 150 mV. (The polarity of the reading will depend on how the test probes are connected to the circuit.)

- c. Connect the digital voltmeter between TP1 and common. The voltage should be $+15\text{Vdc.} \pm 0.6 \text{ Vdc}$.

- d. Connect the digital voltmeter between TP5 and common. The voltage should be $-15\text{Vdc.} \pm 0.6\text{Vdc}$.

- e. Connect the digital voltmeter between TP6 and common. The voltage should be $-5\text{Vdc.} \pm 0.2 \text{ Vdc}$.

5-31. Input Module Adjustments. To adjust the input module, proceed as follows:

a. Gaining Access to Adjustment Controls. To gain access to input module adjustment controls, remove the four screws that attach the input module cover, and remove the cover. If the instrument is equipped with two input modules (option -03), the channel 2 input module will have to be removed temporarily to provide access to the channel 1 input module. The removal procedure for the channel 2 input module is as follows:

1. Remove the four channel 2 input module cover attaching screws, and remove the cover.
2. Remove the channel 2 chopper by unplugging it and positioning it out of the way.
3. Disconnect the voltage supply cable.
4. Disconnect the the 40-pin bus connector.

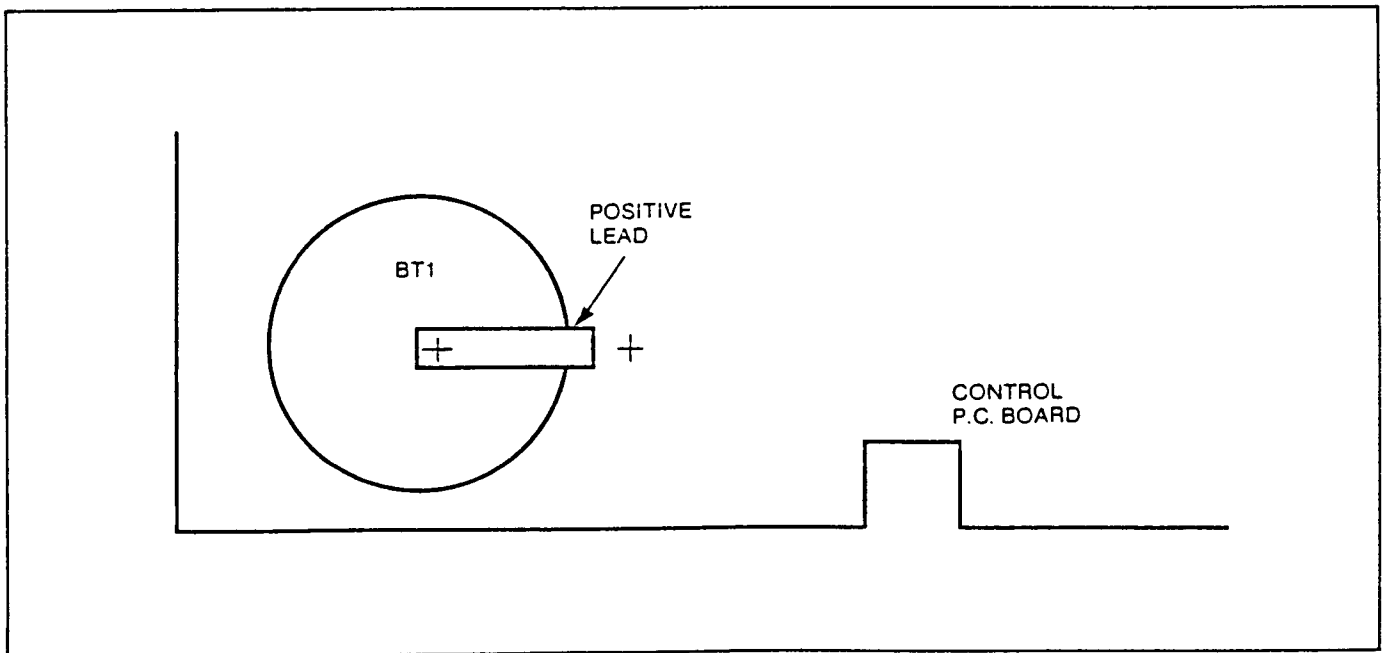

Figure 5-4 Non-Volatile RAM Cell Test and Connection Points

5. Remove the four screws that attach the channel 2 input module to the side frames of the instrument, and remove the channel 2 input module. Take care to ensure that no adjustments are disturbed.

6. Reverse steps 1 through 5 to install the channel 2 input module in the instrument.

b. **Offset Adjustments.** To perform input module offset adjustments, proceed as follows:

1. Turn on the instrument and the Model 2500 range calibrator, and allow the equipment to warm up for at least 30 minutes.

2. Connect the equipment as shown in Figure 5-5.

3. Set the instrument controls as follows:

(a) Set the control board bit switch for calibrate mode 1. (See Figure 5-3.)

(b) Press 1 and SELECT CHNL keys on the keyboard if the channel 1 input module is to be adjusted; press the 2 and SELECT CHNL keys if the channel 2 input module is to be adjusted.

(c) Press the 0 and RANGE HOLD keys on the keyboard.

4. Set the range calibrator and controls to range 0 and 500k Ω source resistance, and press the ZERO button.

5. Connect a digital multimeter between test point TP9 on the input module and common.

6. Connect a clip lead from test point TP8 to chassis or common.

7. Connect a clip lead from test point TP7 to chassis or common.

8. Observe the digital multimeter indication; it should be less than ± 15 millivolts. If the digital multimeter indication is incorrect, adjust potentiometer R45 as required to provide a digital multimeter indication of less than ± 5 millivolts.

9. Remove the clip lead from test point TP8. The digital multimeter indication should be less than ± 15 millivolts. If the digital multimeter indication is incorrect, adjust potentiometer R36 as required to provide a digital multimeter indication of less than ± 5 millivolts.

10. Remove the clip lead from test point TP7.

11. Using the digital multimeter, measure the voltage at test point TP5. The voltage should be less than ± 100 millivolts. If the voltage is incorrect, adjust potentiometer R24 as required to provide a voltage indication of less than ± 100 millivolts.

NOTE

Potentiometer R24 is omitted in later instruments.

12. If no further adjustments are to be performed, set the control board bit switch back to operate mode. (See Figure 5-3.)

c. **Chopper Adjustment.** The preceding offset adjustments must have been completed before chopper adjustment is attempted. To perform the chopper adjustment, proceed as follows:

1. Allow the instrument to warm up for at least 30 minutes.

2. Connect the instrument and test equipment as shown in Figure 5-5.)

3. Set the instrument controls as follows:

(a) Set the control board bit switch for calibrate mode 1. (See Figure 5-3.)

(b) Press the 1 and SELECT CHNL keys on the keyboard if the channel 1 chopper is to be adjusted; press the 2 and SELECT CHNL keys if the channel 2 chopper is to be adjusted.

(c) Press the 0 and RANGE HOLD keys on the keyboard.

4. Set the range calibrator controls to range 0 and 500k Ω source resistance, and press the ZERO button.

5. Using the digital multimeter, measure the voltage at test point TP9 on the input module. Adjust potentiometer R4 and potentiometer R5 on the chopper board equally to obtain a reading from zero to -100 millivolts, but as close to zero as possible.

NOTE

Considerable fluctuation in the digital multimeter indications will be observed during the voltage measurements in the preceding step. The fluctuation is caused by noise, thermals, etc. Mental averaging of the indications will be required.

6. If no further adjustments are to be performed, set the control board bit switch back to operate mode. (See Figure 5-3.)

d. **A/D Converter Adjustment.** Conversion of voltage levels from analog to digital format is performed by the input module A/D converter, which operates in conjunction with the instrument microprocessor and appropriate software. There are two adjustments associated with the A/D converter: an upscale adjustment and a downscale adjustment. These adjustments have been made precisely during the instrument calibration process, and should seldom, if ever, require readjustment; however, if it is desired to check and readjust the A/D converter, the procedure is as follows:

NOTE

The input module offset and chopper adjustments should be completed before proceeding with the A/D converter adjustment.

Section V Maintenance

1. Connect the instrument and test equipment as shown in Figure 5-5. Turn on the instrument and test equipment and allow a warmup period of at least 30 minutes.

2. Set the instrument controls as follows:

(a) Set the control board bit switch to calibrate mode 1. (See Figure 5-3.)

(b) Press the 1 and SELECT CHNL keys on the keyboard if the channel 1 input module is to be adjusted; press the 2 and SELECT CHNL keys on the keyboard if the channel 2 input module is to be adjusted.

(c) Press the 0 and RANGE HOLD keys on the keyboard.

3. Set the range calibrator controls to range 0 and 500k source resistance, and press the ZERO button.

4. Zero the instrument by pressing the ZERO key on the keyboard.

5. Upon completion of the zeroing operation, press the 5 and RANGE HOLD keys on the keyboard.

6. Set the range calibrator to range 5 and release the ZERO button. The indication on the instrument LED display should be 3685. If the indication is incorrect, adjust potentiometer R1 on the input module as required to obtain the 3685 indication on the LED display.

7. Set the range calibrator to range 2. Press 2 and RANGE HOLD keys on the instrument and record the displayed reading.

8. Set the range calibrator to range 1 and adjust R11 for one tenth of the reading recorded on range 2. For example, if the range 2 display was 3680, set range 1 to display 368.

NOTE

If there is not enough range of R1 or R11, center R1 and R11 under the conditions of

paragraph 6 above and adjust R44 to obtain a display of 3.685 on range 5. Then repeat paragraphs 7 and 8 above. There is some interaction between R1 and R11, so recheck adjustments.

9. Set the control board bit switch back to OPERATE MODE. (See Figure 5-3.)

NOTE

Data has been entered into the non-volatile memory of the instrument at the factory for the instrument and for the sensor(s) ordered with the instrument. A copy of the factory-entered data is provided under the right side cover of the instrument. Field entry of data is not required unless stored data is destroyed or its accuracy becomes suspect, or if another sensor is to be used with the instrument.

5-32. DC Calibration. The front end of the instrument input module is a balanced-input DC amplifier with seven decade ranges for nominal inputs of 10 microvolts to 10 volts. The output is an unbalanced DC with a 2.5 volt full scale value for each range; this DC is converted into a proportional digital value. One manual gain adjustment, potentiometer R44, adjusts the gain of all ranges by the same amount; this adjustment is factory set during instrument calibration. Individual range adjustments are accomplished through software correction or adjustment, which is also determined during instrument calibration. The software corrections are stored in the instrument non-volatile memory. A gain factor associated with the recorder DC output is also stored in the memory. To calibrate the DC gain of the instrument, proceed as follows:

a. Connect the instrument and test equipment as shown in Figure 5-5.

b. Set the instrument controls as follows:

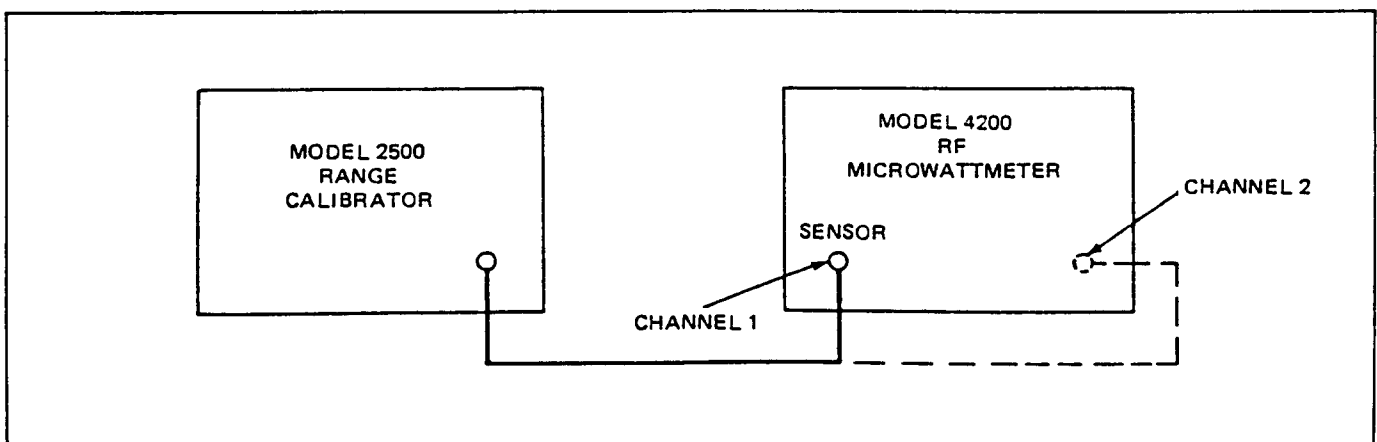

Figure 5-5 Test Setup for Input Module Offset, Chopper, and A/D Converter Adjustments

1. Set the control board bit switch to OPERATE MODE (see Figure 5-3.)
2. Set the range calibrator to range 0 and depress ZERO.
3. Press the 1 and SELECT CHNL keys if channel 1 is to be adjusted; press the 2 and SELECT CHNL keys if channel 2 is to be adjusted.
4. Press the MODE PWR key.
5. Press the 0 and CAL FACTOR dB keys.
6. Press the 0 and REF LEVEL dB keys.
7. Press the ZERO key.
8. After zeroing is completed, set the control board bit switch to CALIBRATE MODE 1 and press, in order, the 1, 0, 0, 0, and RANGE AUTO keys.
9. Release the range calibrator ZERO.
10. Line-by-line set the range calibrator and press the instrument keys as listed in Table 5-24.
11. Disconnect the range calibrator and set the control board bit switch to OPERATE MODE.

5-33. AC Calibration. Two types of data are stored in the instrument non-volatile memory for each sensor that is calibrated with the instrument: low-frequency gain corrections, and high-frequency gain corrections or calibration factors, (The calibration factors are marked on the sensor housing). The low-frequency gain corrections are of two types: a gain factor for each range, and a gain correction for each range. Any sensor procured independently of the instrument must have its low-frequency gain data entered and stored in the non-volatile memory. Entry of high-frequency gain corrections is not absolutely necessary because calibration factors can be read from the sensor housing and entered through the instrument keyboard while using the instrument; however, if the capability of making automatic high-frequency gain corrections as a function of frequency is desired, high-frequency gain corrections must also be entered and stored in the instrument non-volatile memory. To calibrate the low-frequency gain of the instrument, proceed as follows:

NOTE

For 4200-5B and 4200-5E series sensors, increase all the levels indicated below by +10 dBm. For 4200-6 series sensors, increase all levels by +20 dBm. Refer to paragraph 5-41 for procedure to obtain levels sufficient to calibrate the highest range when using a 4200-6 sensor. Refer to paragraph 5-40 for calibrating a 4200-4C sensor.

- a. Connect the instrument and test equipment as shown in Figure 5-6.

NOTE

To calibrate with 4200-5G, 4200-7E or 4200-8E sensors, the Model 25A must be replaced with an equivalent 50 MHz source.

- b. Depress the Model 25A ZERO or 50 MHz source.
 - c. Set the control board bit switch to OPERATE MODE.
 - d. Press in order, the 1, SELECT CHNL, sensor number of 1 through 8, as appropriate (See Section 5-39 for additional sensors), SELECT SENS, 0, CAL FACTOR dB, 0, and REF LEVEL dB keys.
 - e. Set the control board bit switch to CALIBRATE MODE 1.
 - f. If calibrating a 4200-4A, B, C, E series sensor, press, in order, the 0, CAL FACTOR GHz, 1, 0, 0, 0, and CAL FACTOR dB keys.
- If calibrating a 4200-6E series sensor, press, in order, the 2, CAL FACTOR GHz, 1, 0, 0, 0, and CAL FACTOR dB keys.
- If calibrating a 4200-7E sensor, press, in order, the 1, 3, 1, CAL FACTOR GHz, 3, 8, 5, 0, and CAL FACTOR dB keys.
- If calibrating a 4200-8E sensor, press, in order, the 1, 3, 2, CAL FACTOR GHz, 3, 8, 5, 0, and CAL FACTOR dB keys.

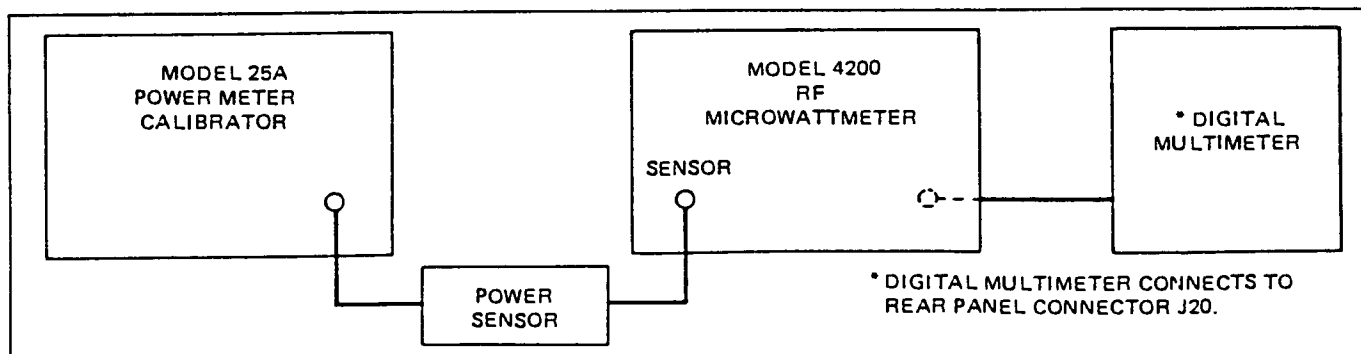

Figure 5-6 Test Setup for Recorder Output Adjustment

TABLE 5-24. DC CALIBRATION TEST

Range Calibrator	Press	Allow settling	Press	Record Display
Range 0	0, RANGE HOLD, 3,6,.,8,5,MODE dB	—	CAL, REF LEVEL dB	≈ 1000
Range 1	1, RANGE HOLD	—	CAL, REF LEVEL dB	≈ 1000
Range 2	2, RANGE HOLD	—	CAL, REF LEVEL dB	≈ 1000
Range 3	3, RANGE HOLD	—	CAL, REF LEVEL dB	≈ 1000
Range 4	4, RANGE HOLD	—	CAL, REF LEVEL dB	≈ 1000
Range 5	5, RANGE HOLD	—	CAL, REF LEVEL dB	≈ 1000
Range 6A*	6, RANGE HOLD	—	CAL, REF LEVEL dB	≈ 1000

*S/N 975 and above if B() series software is used, set Range to 6B. SN 1186 and above set to range 6B.

If calibrating a 4200-5B, E series sensor, press, in order, the 1, CAL FACTOR GHz, 1, 0, 0, 0, and CAL FACTOR dB keys.

If calibrating a 4200-5G series sensor, press, in order, 6, 5, CAL FACTOR GHz, 1, 0, 0, 0, and CAL FACTOR dB keys.

g. Enter the last four digits of the sensor serial number by pressing the appropriate keys followed by the dB LIMITS HI, 1, 0, 0, 0, and RANGE AUTO keys.

NOTE

Pressing N and then HOLD selects range N.

h. Set the control board bit switch to CALIBRATE MODE 2 for subsequent operations.

i. Zero the 4200 by pressing 0, HOLD, ZERO. Wait for the completion of the zeroing process (digit display indicates cccc then returns to numeric display).

j. To adjust the full scale gain, set the Model 25A or 50 MHz source and 4200 as listed in Table 5-25.

k. Set 25A or 50 MHz source for no output. Set the control board bit switch to OPERATE MODE and press RANGE AUTO, ZERO.

l. To calculate the down scale corrections, set the Model 25A or 50 MHz source and 4200 as listed in Table 5-26.

NOTE

There is a one-to-one relationship between the counts entered for the downscale correction (X) and the correction which results.

Example True reading = 1.000 μW
Display reading = 1.006 μW
Downscale correction = -6

Always use whole numbers: the idea is for display reading to equal true reading.

True reading = 10.00 μW
Display reading = 9.95 μW
Downscale correction = 5

m. To enter the downscale correction, refer to Table 5-27 and set the bit switch to CALIBRATE MODE 2.

n. Set the bit switch to OPERATE MODE and check accuracy.

o. If after checking accuracy there are out-of-tolerance conditions, the quality of each range may be changed as follows:

Example

OPERATE MODE input = -44 dBm

Display reads -44.30 dBm

The difference is 30 counts low. In dBm mode, there is a twenty-to-one relationship between the counts entered for full scale correction and the correction which results: $20 \times 30 = 600$

Set the bit switch to CALIBRATE MODE 2 and recall gain factor by pressing HOLD, REF LEVEL dB. A gain factor of 5000 is displayed. Increase gain factor by 600 by pressing: 5,6,0,0, REF LEVEL dB. Recheck in OPERATE MODE. If the example display was 30 counts high, a correction would have been made 600 counts lower or 4400.

5-34. Display Board Recorder Output Adjustment. To check and adjust the recorder output, proceed as follows:

**TABLE 5-25. FULL SCALE SENSOR CALIBRATION DATA
FOR 4A, 4B, 4C, 5B*, 5E* AND 6E* SERIES SENSORS**

25A 50MHz	Press	Allow settling	Press	Record Display
- 54dBm(.398nW)	0,HOLD,3,9,..,8 0,MODE dB	—	CAL,0,HI, REF LVL dB	≈ 5000
- 44dBm(3.98nW)	1,HOLD,3,9,..,8 0,MODE dB	—	CAL,0,HI, REF LVL dB	≈ 5000
- 34dBm(39.8nW)	2,HOLD,3,9,..,8 0,MODE dB	—	CAL,0,HI, REF LVL dB	≈ 5000
- 24dBm(3.98μW)	3,HOLD,3,9,..,8 0,MODE dB	—	CAL,0,HI, REF LVL dB	≈ 5000
- 14dBm(39.8μW)	4,HOLD,3,9,..,8 0,MODE dB	—	CAL,0,HI, REF LVL dB	≈ 5000
0dBm(1.00mW)	5,HOLD,9,9,..,9 9,MODE dB	—	CAL,0,HI, REF LVL dB	≈ 5000
+ 10dBm(10.0mW)	6,HOLD,9,9,..,9 9,MODE dB	—	CAL,0,HI, REF LVL dB	≈ 5000

*All levels should be increased by 10 dB for 5B and 5E sensors and 20 dB for 6E sensor.

FOR 5G SERIES SENSOR

50MHz source	Press	Allow settling	Press	Record Display
- 29dBm(1.26μW)	2,HOLD,1,2,..,6 0,MODE dB	—	CAL,0,HI, REF LVL dB	≈ 5000
- 19dBm(12.6μW)	3,HOLD,1,2,..,6 0,MODE dB	—	CAL,0,HI, REF LVL dB	≈ 5000
- 6dBm(.251mW)	4,HOLD,2,5,..,1 0,MODE dB	—	CAL,0,HI, REF LVL dB	≈ 5000
+ 7dBm(5.01mW)	5,HOLD,5,0,..,1 0,MODE dB	—	CAL,0,HI, REF LVL dB	≈ 5000
+ 19dBm(79.4mW)	6,HOLD,7,9,..,4 0,MODE dB	—	CAL,0,HI, REF LVL dB	≈ 5000
	0,HOLD,0,REF LVL dB,0,HI			
	0,HOLD,0,REF LVL dB,0,HI			

FOR 7E AND 8E* SERIES SENSORS

50MHz source	Press	Allow settling	Press	Record Display
- 20dBm(10.0μW)	0,HOLD,9,9,..,9 9,MODE dB	—	CAL,0,HI, REF LVL dB	≈ 5000
- 10dBm(100μW)	1,HOLD,9,9,..,9 9,MODE dB	—	CAL,0,HI, REF LVL dB	≈ 5000
0dBm(1.00mW)	2,HOLD,9,9,..,9 9,MODE dB	—	CAL,0,HI, REF LVL dB	≈ 5000
+ 10dBm(10.0mW)	3,HOLD,9,9,..,9 9,MODE dB	—	CAL,0,HI, REF LVL dB	≈ 5000
	4,HOLD,0,REF LVL dB,0,HI			
	5,HOLD,0,REF LVL dB,0,HI			
	6,HOLD,0,REF LVL dB,0,HI			

*Increase level by 10 dB for 8E sensor.

**Section V
Maintenance**

**TABLE 5-26. DOWN SCALE SENSOR CALIBRATION DATA
FOR 4A, 4B, 4C, 4E, 5B*, 5E* AND 6E* SERIES SENSORS**

25A or 50MHz	Record Display Reading	True Reading	Downscale Correction
- 60dBm(1.00nW)		1.00nW	Range 0 =
- 50dBm(10.00nW)		10.00nW	Range 1 =
- 40dBm(100.0nW)		100.0nW	Range 2 =
- 30dBm(1.000µW)		1.000µW	Range 3 =
- 20dBm(10.00µW)		10.00µW	Range 4 =
- 10dBm(100.0µW)		100.0µW	Range 5 =
+ 3dBm(2.00mW)		2.00mW	Range 6 =

*All levels should be increased by 10 dB for 5B and 5E sensors and 20 dB for 6E sensor.

FOR 5G SERIES SENSOR

50MHz source	Record Display Reading	True Reading	Downscale Correction
- 37dBm(.200µW)		.200µW	Range 2 =
- 26dBm(2.51µW)		2.51µW	Range 3 =
- 16dBm(25.1µW)		25.1µW	Range 4 =
- 3dBm(.501mW)		.501mW	Range 5 =
+ 10dBm(10.0mW)		10.0mW	Range 6 =

FOR 7E AND 8E SERIES SENSORS

50MHz source	Record Display Reading	True Reading	Downscale Correction
- 26dBm(2.51µW)		2.51µW	Range 0 =
- 16dBm(25.1µW)		25.1µW	Range 1 =
- 6dBm(.251mW)		.251mW	Range 2 =
+ 4dBm(2.51mW)		2.51mW	Range 3 =

TABLE 5-27. DOWNSCALE CORRECTION DATA

PRESS							
0,	HOLD,	X,	X,	X,	X,	HI	
1,	HOLD,	X,	X,	X,	X,	HI	
2,	HOLD,	X,	X,	X,	X,	HI	
3,	HOLD,	X,	X,	X,	X,	HI	
4,	HOLD,	X,	X,	X,	X,	HI	
5,	HOLD,	X,	X,	X,	X,	HI	
6,	HOLD,	X,	X,	X,	X,	HI	

X Denotes downscale correction

a. Connect the instrument and test equipment as shown in Figure 5-6.

b. Set the instrument controls as follows:

1. Press the MODE PWR key on the keyboard.
2. Press the RANGE AUTO key on the keyboard.
3. Press the 0 and CAL FACTOR dB keys on the keyboard.
4. Press the 0 and REF LEVEL dB keys on the keyboard.

c. Set the power meter calibrator output to 1 mW.

d. Check the indication on the LED display of the instrument. If the indication is not 1.000 mW, press the CAL key.

* e. With 1.000 mW indicated on the LED display, check the indication on the digital multimeter; it should be 9.98 to 10.00 volts. If the indication is correct, proceed directly to step h; if the indication is incorrect, proceed to step f.

* f. If the digital multimeter indication in preceding step e was incorrect, set the control board bit switch to CALIBRATE MODE 1 (see Figure 5-3) and press the dB LIMITS LO key on the keyboard. The LED display will show a gain modifier of approximately 3600. Calculate a revised gain modifier value to obtain the required correction. For example: if the digital multimeter indication were 9.96 volts (0.4% low) and the dB LIMITS LO key recalled a gain modifier of 3500, the revised gain modifier value would be:
 $1.004 \times 3500 = 3514$

Enter this revised gain modifier value by pressing the following keys on the keyboard:

3, 5, 1, 4,
 dB LIMITS LO,
 dB LIMITS LO (revised value should appear on the LED display)

* g. Reset the control board bit switch to OPERATE MODE 0. (See Figure 5-3.) Note the indication on the digital multimeter; it should be 9.98 to 10.00 volts. Repeat steps f and g, if necessary, until the correct indication is obtained.

* h. Set the power meter calibrator output to 0.125 mW, and observe the indications on the instrument LED display and on the digital multimeter. The millivolt indication on the digital multimeter should equal ten times the value shown on the LED display ± 1 count. If the digital multimeter indication is incorrect, adjust potentiometer R55 on the input module board as required to provide the proper digital multimeter indication.

i. Repeat steps e through h until no further adjustments are necessary.

* See instruction-manual supplement

NOTE

Make sure that control board bit switch is set back to OPERATE MODE upon completion of adjustments.

5-35. Power Reference Adjustment. To check and adjust the power reference output, proceed as follows:

a. Connect a 50-ohm test probe to a Model EPM-1 milliwatt test set.

b. Turn on the milliwatt test set and the instrument. Allow the milliwatt test set and the instrument to warm up for at least 30 minutes.

c. Standardize the milliwatt test set in accordance with the manufacturer's instructions.

d. Connect the probe of the milliwatt test set to the POWER REF connector of the instrument and note the indication on the milliwatt test set. The indication should be within ± 0.005 dB.

NOTE

If the indication in step d is within the specified limits, no adjustment of the power reference is required. Proceed with the following steps only if the indication is outside the specified limits.

e. Remove the bottom cover.

f. Remove the bottom front trim strip from the instrument by removing the two screws (one on each side) that secure the trim strip.

g. Locate the power reference adjustment. (See Figure 5-1.)

h. Adjust the power reference adjustment R4 as required to obtain an indication of 0 dBm ± 0.005 dB on the milliwatt test set.

i. Restandardize the milliwatt test set and recheck the power reference. Readjust the power reference adjustment as necessary.

j. Turn off the instrument and the milliwatt test set. Install the trim strips and cover.

5-36. Entry of Sensor Calibration Factors Versus Frequency. Proceed as follows:

NOTE

The 4200 is capable of storing twenty calibration factors (0 through 19) for each sensor (from 1 to 8) programmed into the instrument. Frequencies must be in ascending order, starting with the lowest and

Section V Maintenance

advancing in sequence to the highest. If less than twenty calibration factors are to be entered, enter the calibration factors available then fill the remaining positions with the highest frequency and associated calibration factor.

a. Using the keyboard keys, select the sensor for which calibration factors are to be entered. For example, if the calibration factors to be entered are for sensor 4, press the 4 and SELECT SENS keys.

b. To confirm correct sensor selection press the SELECT SENS key. The number of the selected sensor will appear on the instrument LED display.

c. Set the control board bit switch, to CALIBRATE MODE 2. Refer to Figure 5-3.

d. Using the keyboard keys, enter the calibration factor position number (0 through 19) followed by the RANGE AUTO key.

For example: to enter a frequency and calibration factor into position 0, press the 0 key followed by the RANGE AUTO key.

e. Using the keyboard keys, enter the frequency to which the sensor calibration factor to be entered applies.

For example: if the sensor calibration factor to be entered applies to a frequency of 0.1 GHz, press the 0, ., and 1 numeric key, then press the CAL FACTOR GHz key. (Frequencies of 0.1 GHz through 110 GHz are valid).

f. Using the numerical keys, enter the sensor calibration factor for the frequency selected in step e. (For negative values, press the CHS key after entering the sensor calibration factor value.) After entering the correct sensor calibration factor value, press the CAL FACTOR dB key. (Values of -3.00 to +3.00 are valid.)

g. Repeat steps d through f until all twenty positions are filled.

h. Press the 0 and RANGE AUTO keys.

i. Set the control board bit switch, to the OPERATE MODE. Refer to Figure 5-3.

5-37. SENSOR CALIBRATION

5-38. General. In order to use a sensor for which calibration data is unknown, the following requirements must be met:

a. The control board bit switch must be set to accept another sensor number without returning an error indication. Data is stored in the instrument non-volatile memory for the number of sensors procured with the instrument; if a sensor number other than any of those for which data is stored is selected, an error message is displayed on the instrument LED display, thereby indicating an empty storage

location. The control board bit switch is set to accept this number as the number of the sensor for which new data is to be entered, and the error indication is erased automatically. The maximum number of sensors for which data may be stored is eight. If data for eight sensors is already in storage and it is desired to use another sensor, the data already in storage for one of the sensors must be over written.

b. Serial number, type, and attenuation data for the new sensor must be entered into non-volatile memory. (See Section 5-33)

c. Gain factors and gain corrections for the new sensor must be developed, entered, and checked. A calibration source is required for this function. (See Section 5-33)

d. Calibration factors versus frequency, which are shown on the barrel of the sensor, must be entered into non-volatile memory. (See Section 5-36)

5-39. Bit Switch Setting For Additional Sensor. To determine the correct bit switch setting for the new sensor, proceed as follows:

a. If the number of sensors for which data is already stored is unknown, select sensors in sequence through the keyboard until an error indication (CC02) appears on the instrument LED display. For example, press the 1 and SELECT SENS keys, the 2 and SELECT SENS keys, the 3 and SELECT SENS keys, and the 4 and SELECT SENS keys.

b. When an error indication is returned, press the SELECT SENS key a second time; if the LED display does not indicate the last selected sensor number, it can be assumed that no data has been entered in non-volatile memory for this sensor number.

c. Set the control board bit switch (Figure 5-3) to accept the sensor number that produced the error indication and mark this sensor number on the sensor barrel.

5-40. Calibration of Model 4200-4C Sensor. The calibration procedures for this sensor are the same as those for other sensors, except that a 50-ohm to 75-ohm transformer is required between the power meter calibrator and the sensor. Any loss or gain introduced by the transformer must be taken into account during the calibration procedure. For example, if a transformer with a loss of 0.05 dB at 1 MHz is used, the LED display indications must be reduced by 0.05 dB while the input levels remain the same.

NOTE

When making final calibration checks of the sensor, the transformer loss in the example

above can be compensated for by entering a calibration factor of +0.05 dB into the instrument.

5-41. Calibration Notes, Model 4200-6 Sensor +30 dBm Range.

5-42. The maximum output level of the Model 25A calibrator, which is recommended for instrument calibration, is +20 dBm. Because levels of +20 to +30 dBm are required for checking or calibrating the highest range of the 4200-6 sensor, an amplifier with an exact gain of 10 in power and a capability of delivering 1 watt into 50 ohms at 1 MHz is required. The procedure which follows outlines an alternate method for checking this range.

a. Calibrate and/or check the instrument with the 4200-6 sensor on all ranges except the highest (+30 dBm) range as outlined in paragraph 5-33.

b. Connect the instrument and test equipment as shown in Figure 5-7. A small fan directed at the Model ZHL-3A will minimize drift. The exact attenuation of the 10 dB, 50 ohm attenuator must be known. If the exact attenuation is unknown, it can be determined with a reasonable degree of accuracy as follows:

1. With the Model 25A, the instrument, and the 4200-6 sensor calibrated or checked as in paragraph a above, set the output of the Model 25A to 10 dBm and connect the equipment as shown in Figure 5-8.

2. Note the reading on the instrument display. The attenuation value of the 10 dBm attenuator is 10 dBm minus the dBm indication on the instrument display. Higher resolution may be obtained by operating the instrument in the PWR mode and calculating the attenuation value from:

Attenuation (dB) =

$$\log \frac{10.00 \text{ mW}}{\text{Instrument indication (mW) with 10 dB attenuator}}$$

c. Using the test setup shown in Figure 5-7, note and record the indication on the instrument display as the Model 25A output level is varied over the range of +10 dBm to +1 dBm. A tabular form as shown in Table 5-28 is recommended. In Table 5-28, the first column is the Model 25A output setting, and the second column lists indications typical of what might be expected. These two columns amount to a calibration of the Model 25A – Model ZHL-3A combination.

d. Remove the 10 dB attenuator from the test setup shown in Figure 5-7, and connect the 4200-6 sensor directly to the Model ZHL-3A. Set the Model 25A output to the levels listed in the first column of Table 5-28, and record the indications on the instrument display in the third column of the table. Ideally, the values listed in the third column will equal those listed in the second column plus the exact

attenuation value of the 10 dB attenuator. If the values listed in the third column are within ± 0.02 of the values listed in the second column plus the exact value of the 10 dB attenuator, no adjustment on this range is needed. If readjustment is desired, proceed to paragraph 5-44.

NOTE

At the higher output level, the output will be distorted; however, this does not matter since the same distortion exists in both determinations (second and third columns).

5-43. In the +30 dBm range adjustment procedure that follows, it is assumed that the 4200-6 sensor has been previously calibrated with the instrument. The adjustment value is stored in REF LEVEL dB: this value will be in the vicinity of 5000. If the 4200-6 sensor has not been calibrated with the instrument, 5000 should be stored initially and adjusted as necessary. Use the following procedure:

a. Set the Model 25A output to +7 dBm.

b. Set the control board bit switch (Figure 5-3) to CALIBRATE MODE 2 (switch No. 2 open).

c. Press the instrument REF LEVEL dB key. The display will indicate a number in the vicinity of 5000.

d. If the 4200-6 sensor has not been calibrated previously, enter 5000 as the initial value by pressing the 5, 0, 0, 0, and REF LEVEL dB keys. Repeat the procedures of paragraphs 5-42c, 5-42d, and 5-43a through 5-43c.

e. Adjust the value obtained in paragraph c above in the desired direction by increasing or decreasing this value. A change of 12 counts in this value corresponds to a change of approximately 0.01 dB. For example: if the recorded indication in Table 5-28 were 25.34 dBm rather than 25.32 dBm as required, a correction of -0.02 dB is necessary; therefore, 24 counts should be subtracted from the value obtained in paragraph c above. To enter this new value, press the N, N, N, N, and REF LEVEL dB keys.

f. After entering the adjusted value, set the control board bit switch (Figure 5-3) to the OPERATE MODE (switch No. 2 closed), and recheck the performance by returning to paragraph 5-43c.

5-44. If the difference in the last column of Table 5-23 exceeds ± 0.02 dB for the 3, 4, or 5 dBm setting of the Model 25A, this difference may be reduced as follows:

a. Set the Model 25A output to +4 dBm.

b. Set the control board bit switch (Figure 5-3) to

Section V
Maintenance

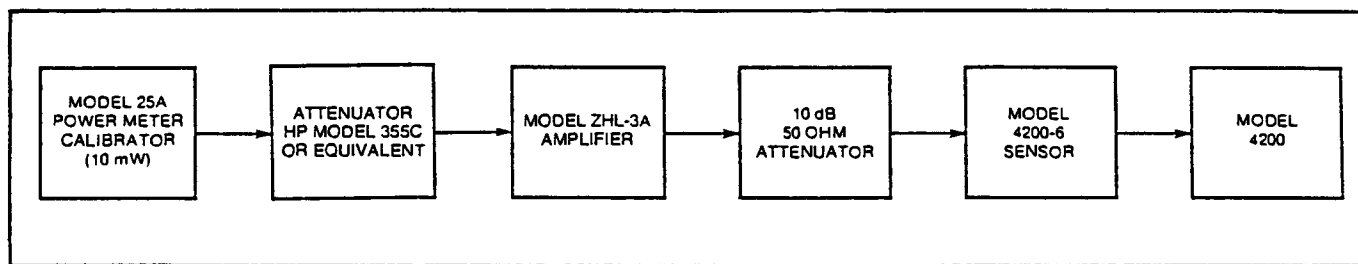

Figure 5-7. Test Setup for Determination of Attenuation Value

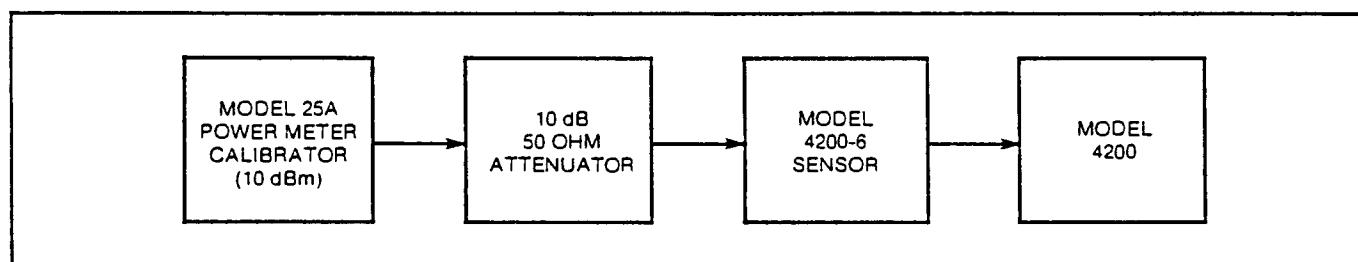

Figure 5-8. Calibration Test Setup, Model 4200-6 Sensor, +30 dBm Range

TABLE 5-28. TYPICAL CALIBRATION DATA FOR MODEL 4200-6 SENSOR WITH MODEL 4200

Model 25A Level	Model 4200 Indication with 10 dB Atten.	Model 4200 Indication Without 10 dB Atten.	Difference
10 dBm	20.02 dBm	30.03 dBm	+0.01 dB
9 dBm	19.02 dBm	29.04 dBm	+0.02 dB
8 dBm	18.06 dBm	28.07 dBm	+0.01 dB
7 dBm	17.09 dBm	27.09 dBm	0.00 dB
6 dBm	16.12 dBm	26.11 dBm	-0.01 dB
5 dBm	15.13 dBm	25.12 dBm	-0.01 dB
4 dBm	14.15 dBm	24.13 dBm	-0.02 dB
3 dBm	13.16 dBm	23.16 dBm	0.00 dB
2 dBm	12.18 dBm	22.18 dBm	0.00 dB
1 dBm	11.17 dBm	21.18 dBm	+0.01 dB

CALIBRATE MODE 2 (switch No. 2 open).

c. Press the dB LIMITS HI key on the instrument front panel and note the value shown on the instrument display.

d. Increase or decrease this value as required in steps of 5 or 10 counts, returning the control board bit switch to the OPERATE MODE (switch No. 2 closed), and noting the

result. Repeat the adjustment as necessary to obtain the desired indication.

e. Recheck the entire range, starting with paragraph 5-43c.

f. At the conclusion of the procedure, be sure to return the control board bit switch to the OPERATE MODE (switch No. 2 closed).

SECTION VI PARTS LIST

6-1. INTRODUCTION

Table 6-2. Replaceable Parts, list all the replaceable parts and includes: the reference symbol, description, Mfr., Mfr's Part No, and the BEC Part No, Table 6-1. Manu-

facturer's Federal Supply Code Numbers, list the manufacturer's federal supply numbers.

TABLE 6-1. MANUFACTURER'S FEDERAL SUPPLY CODE NUMBERS

NUMBER	NAME	NUMBER	NAME	NUMBER	NAME
00241	Fenwal Electronics	20307	Arco - Micronics	54420	Dage - MTI
01121	Allen Bradley	24266	Gowanda Electronics	54426	Buss Fuses
01247	Sprague Electric Company	27014	National Semiconductor	54473	Panasonic
01295	Texas Instruments	27264	Molex, Inc.	56289	Sprague Electric Company
02660	Amphenol	27735	F-Dyne Electronics	56708	Zilog, Inc.
02735	RCA Solid State Division	27777	Varo Semiconductor	57582	Kahgan Electronics Corp.
03888	Pyrofilm (KDI)	28480	Hewlett-Packard Corp.	61637	Kemet-Union Carbide
04713	Motorola Semiconductor	31313	Components Corp.	71450	CTS Corp.
04901	Boonton Electronics	31918	ITT Schadow, Inc.	73138	Beckman Instru., Helipot Div.
06383	Panduit Corp.	32575	AMP	81073	Grayhill
06776	Robinson Nugent, Inc.	32897	Eric	91293	Johanson
07263	Fairchild Semiconductor	32997	Boums, Inc., Trimpot Div.	91506	Augat
07326	Fairchild Semiconductor	33297	NEC	98291	Sealectro Corp.
13812	Dialco Div. of Amperex	33883	RMC	99942	Centralab
14655	Cornell-Dubilier	34335	Advanced Micro Devices	S4217	United Chemicon, Inc.
17801	Panel Corp. (Schurter)	51640	Analog Devices, Inc.		
19701	Mepeo Electra	52464	OKI		

TABLE 6-2. REPLACEABLE PARTS

94004302A OPCODE: 0 REV: 8* COMMON CHASSIS 4200
MODEL: 4200

REFERENCE DESIGNATOR	DESCRIPTION	FED. CODE	MANUFACTURER PART NUMBER	QTY	BEC PART NUMBER
A5	(G) PWA CONTROL	04901	04223400E	1	04223400E
A2(2)	(G) PWA DISPLAY	04901	04235800C	1	04235800C
A7(5)	(G) PWA POWER SUPPLY	04901	04223100C	1	04223100C
A5(15)	(G) PWA INPUT	04901	04223001B	1	04223001B
J26	(G) CONNECTOR ASSY FEMALE	04901	09214101C	1	09214101C
J1-03	(G) CONNECTOR ASSY FEMALE	04901	09214101C	1	09214101C
J36-04	(G) CONNECTOR ASSY FEMALE	04901	09214101C	1	09214101C
W17	(G) CABLE UNIT 16 PIN	04901	92004600B	1	92004600B
W20	CABLE FLAT UNIT	04901	920052000	1	920052000
W12	(G) CABLE ASSY PS TO DISPLAY	04901	57114200D	1	57114200D
W13	(G) CABLE ASSY PS TO CONTROL	04901	57114400C	1	57114400C
W14	(G) CABLE ASSY PS -CONTROL #2	04901	57114500C	1	57114500C
W16	(G) CABLE ASSY PS TO INPUT	04901	57114300C	1	57114300C
W21	(G) CABLE ASSY PS TO INTERFACE	04901	57114700C	1	57114700C

Section VI
Parts List

6-2. Replaceable Parts (Continued)

04223400E OPCODE: 0 REV: G* (G) PWA CONTROL
MODEL: 4200

REFERENCE DESIGNATOR	DESCRIPTION	FED. CODE	MANUFACTURER PART NUMBER	QTY	BEC PART NUMBER
BT1	CELL LITHIUM 3V	54473	BR2325-1HB	1	556007000
C1	CAP MICA 430pF 1% 500V	14655	CD15FD431F03	1	200037000
C2	CAP MICA 100pF 5% 500V	14655	CM05FD101J03	1	200001000
C3	CAP TANT 15uF 10% 20V	56289	196D156X9020KA1	1	283227000
C4-7	CAP EL 10uF 20% 25V	54217	SM-25-V8-10-M	4	283336000
CR1-2	DIODE SIG 1N914	01295	1N914	2	530058000
IC1	IC 7404 HEX INVERTER	01295	SN7404N	1	534042000
IC2	RES NETWORK 4.7K 2% 1.8W	01121	316B472	1	345020000
IC3	IC Z80-CPU-PS	56708	Z80-CPU-PS	1	534159000
IC4	IC 74LS42 4-10 DECODER	01295	SN74LS42N	1	534210000
IC8	IC MSM5128-20-RS RAM 2K X 8	52464	MSM5128-20-RS	1	534304000
IC9	IC 4011 QUAD 2 INPUT NAND	02735	CD4011AE	1	534022000
IC13	RES NETWORK 4.7K 2% 1.8W	01121	316B472	1	345020000
IC14	IC 74LS42 4-10 DECODER	01295	SN74LS42N	1	534210000
IC15	IC 74LS32 QUAD 2 INPUT OR	01295	SN74LS32N	1	534168000
IC16	IC 8255APC PERIPH INTERFACE	34335	AM8255APC	1	534171000
IC17	RES NETWORK 4.7K 2% 1.8W	01121	316B472	1	345020000
IC18	IC 8279-2 KEYBD/DISP INTERFACE	33297	UPD8279C-2	1	534211000
JB	CONNECTOR 2 PIN STRAIGHT	27264	22-03-2021	1	477361000
JA	CONNECTOR 2 PIN STRAIGHT	27264	22-03-2021	1	477361000
J1-2	SOCKET IC 16 PIN	06776	ICN-163-S3-G	2	473042000
J5	CONNECTOR 2 PIN STRAIGHT	27264	22-03-2021	1	477361000
L1	INDUCTOR 15uH 10%	24226	10M152K	1	400373000
PB	SHUNT 2 CIRCUIT	27264	15-38-1024	1	483253000
PA	SHUNT 2 CIRCUIT	27264	15-38-1024	1	483253000
P1	SHUNT 8 CIRCUIT	32575	435704-8	1	483226000
P2	(G) CONNECTOR 5 PIN RT ANG MOD	04901	47733300A	1	47733300A
P3	(G) CONNECTOR 5 PIN RT ANG MOD	04901	47733200B	1	47733200B
P4	(G) CONNECTOR 6 PIN RT ANG MOD	04901	47733100A	1	47733100A
P5	SHUNT 2 CIRCUIT	27264	15-38-1024	1	483253000
Q1	TRANS NPN 2N3904	04713	2N3904	1	528071000
R1	RES MF 332 OHM 1% 1/4W	19701	5043ED332R0F	1	341250000
R2-3	RES MF 10.0K 1% 1/4W	19701	5043ED10K00F	2	341400000
R4-5	RES MF 5.11K 1% 1/4W	19701	5043ED5K110F	2	341368000
R6	RES MF 100 OHM 1% 1/4W	19701	5043ED100R0F	1	341200000
R7	RES MF 10.0K 1% 1/4W	19701	5043ED10K00F	1	341400000
R8	RES MF 5.11K 1% 1/4W	19701	5043ED5K110F	1	341368000
R9-11	RES MF 4.75K 1% 1/4W	19701	5043ED4K750F	3	341365000
S1	SWITCH ROCKER SPST DIP	81073	76SB08	1	465225000
XIC3	SOCKET IC 40 PIN	06776	ICN-406-S4-TG	1	473052000
XIC6-8	SOCKET IC 24 PIN	06776	ICN-246-S4-G	3	473043000
XIC16	SOCKET IC 40 PIN	06776	ICN-406-S4-TG	1	473052000
XIC18	SOCKET IC 40 PIN	06776	ICN-406-S4-TG	1	473052000
XS1	SOCKET IC 16 PIN	06776	ICN-163-S3-G	1	473042000

04236201B OPCODE: 0 REV: D- UNIQUE CONFIG PARTS 4200
MODEL: 4200

REFERENCE DESIGNATOR	DESCRIPTION	FED. CODE	MANUFACTURER PART NUMBER	QTY	BEC PART NUMBER
IC6A5	IC EPROM PROG. 3658G 4200	04901	53436500H	1	53436500H
IC7A5	IC EPROM PROG. 3148G 4200	04901	53431400H	1	53431400H

6-2. Replaceable Parts (Continued)

Section VI
Parts List04235800C OPCODE: 0 REV: C* (G) PWA DISPLAY
MODEL: 4200

REFERENCE DESIGNATOR	DESCRIPTION	FED. CODE	MANUFACTURER PART NUMBER	QTY	BEC PART NUMBER
C3-4	CAP EL 10uF 20% 25V	54217	SM-25-VB-10-M	2	283336000
CR1-13	LED RED DIFF 5092-4684	28480	HLMP-1301	13	536024000
IC1	IC 74C48 BCD 7 SEG DECODER	27014	MM74C48N	1	534214000
IC2	IC 4051B 8 CHAN MULT/DEMULPL	02735	CD4051BE	1	534139000
IC3	IC 4049A HEX BUFF	02735	CD4049AE	1	534172000
IC4	RES NETWORK 100 OHM 2% 1.8W	01121	316B101	1	345021000
IC5	RES NETWORK 4.7K 2% 1.8W	01121	316B472	1	345020000
IC6	DISPLAY NUMERIC 5082-7653	28480	5082-7653	1	536809000
IC7	IC 8863 DRIVER	27014	DS8863N	1	534215000
IC8-11	DISPLAY NUMERIC 5082-7653	28480	5082-7653	4	536809000
J1	SOCKET IC 16 PIN	06776	ICN-163-S3-G	1	473042000
M1	METER MARKED	MODTEC	00-700-098	1	55433500A
P1	CONNECTOR 6 PIN STRAIGHT POLAR	27264	22-04-2061	1	477327000
P2	HEADER 2 PIN RT ANGLE	06383	HFA5100-2-C	1	477367000
Q1	TRANS NPN 2N5088 BLUE	04713	2N5088	1	528047000
R4	RES MF 9.09K 1% 1/4W	19701	5043ED9K090F	1	341392000
R5	RES MF 8.87K 1% 1/4W	19701	5043ED8K870F	1	341391000
R6	RES MF 15.0K 1% 1/4W	19701	5043ED15K00F	1	341417000
R7	RES MF 4.75K 1% 1/4W	19701	5043ED4K750F	1	341365000
S1-26	SWITCH PUSHBUTTON SPST	31918	210272	26	465230000
XIC6	SOCKET IC 14 PIN	06776	ICN-143-S3-G	1	473019000
XIC8-11	SOCKET IC 14 PIN	06776	ICN-143-S3-G	4	473019000

04223001B OPCODE: 0 REV: C* (G) PWA INPUT AND PWA INPUT -03 OPT
04223002B
MODEL: 4200

REFERENCE DESIGNATOR	DESCRIPTION	FED. CODE	MANUFACTURER PART NUMBER	QTY	BEC PART NUMBER
AR1	IC 301A OP AMP	27014	LM301AN	1	535012000
AR2	IC 311N OP AMP COMPARATOR	27014	LM311N	1	535034000
AR3	IC 301A OP AMP	27014	LM301AN	1	535012000
AR4	IC 3140 OP AMP	02735	CA3140AE	1	535050000
AR5-6	(G) IC 356B OP AMP SELECTED	04901	535062000	2	535062000
AR7	(G) IC SELECTED LF356 OPAMP	04901	535079000	1	535079000
AR8-9	IC 3140 OP AMP	02735	CA3140AE	2	535050000
C1	CAP CER 33pF 5% 1000V	56289	10TCC-Q33	1	224139000
C2	CAP EL 10uF 20% 25V	54217	SM-25-VB-10-M	1	283336000
C3	CAP CER 33pF 5% 1000V	56289	10TCC-Q33	1	224139000
C4	CAP PE 0.01uF 10% 80V	56289	192P1039R8	1	234092000
C5	CAP CER 150pF 10% 600V	16546	CE-151	1	224314000
C6-7	CAP CER 33pF 5% 1000V	56289	10TCC-Q33	2	224139000
C8	CAP CER 1000pF 10% 600V	16546	CE-102	1	224310000
C9	CAP MICA 1500pF 1% 500V	14655	CD19FD152F	1	200531000
C12	CAP CER 0.01uF 100V	33883	BT Z5U	1	224119000
C13	CAP CER 68pF 10% 600V	16546	DTZ-68	1	224312000
C14	CAP PE 0.01uF 10% 80V	56289	192P1039R8	1	234092000
C15	CAP CER 0.01uF 100V	33883	BT Z5U	1	224119000
C16	CAP CER 68pF 10% 600V	16546	DTZ-68	1	224312000
C17	CAP CER 2200pF 10% 250V	16546	CF-222	1	224309000
C18	CAP PE 0.01uF 10% 80V	56289	192P1039R8	1	234092000
C19	CAP CER 330pF 10% 600V	16546	CE-331	1	224313000
C20	CAP PP 0.1uF 10% 100V	27735	PP11-.1-10-100	1	234148000
C22	CAP PP 0.1uF 10% 100V	27735	PP11-.1-10-100	1	234148000
C23	CAP CER 33pF 5% 1000V	56289	10TCC-Q33	1	224139000
C25	CAP CER 33pF 5% 1000V	56289	10TCC-Q33	1	224139000
C26	CAP CER 1000pF 10% 600V	16546	CE-102	1	224310000

Section VI
Parts List

6-2. Replaceable Parts (Continued)

04223001B
04223002B
MODEL: 4200

OPCODE: 0 REV: C* (G) PWA INPUT AND PWA INPUT -03 OPT

REFERENCE DESIGNATOR	DESCRIPTION	FED. CODE	MANUFACTURER PART NUMBER	QTY	BEC PART NUMBER
C27-34	CAP EL 10uF 20% 25V	S4217	SM-25-VB-10-M	8	283336000
C35	CAP CER 150pF 10% 600V	16546	CE-151	1	224314000
C36	CAP EL 100uF 20% 25V	S4217	SM-25-VB-100-M	1	283334000
C37	CAP CER 1000pF 10% 600V	16546	CE-102	1	224310000
IC1	IC 8255APC PERIPH INTERFACE	34335	AM8255APC	1	534171000
IC2	IC 565 D/A CONVERTER 12 BIT	51640	AD565AJD	1	421034000
IC3	IC 4053B TRPL DECDR/DEMULTPXR	04713	MC14053BCP	1	534207000
IC5	IC 4047A MULTIVIB (RCA ONLY)	02735	CD4047AE	1	534229000
IC6	IC 4051B MULTIPLEXER RCA ONLY	02735	CD4051BE	1	534209000
IC7-8	IC 4013B DUAL FLIP FLOP	02735	CD4013BE	2	534205000
IC9-10	(G) IC 4016B QUAD SWITCH	02735	CD4016BE	2	534218000
IC11	IC 4075B TRPL 2 INPUT OR	02735	CD4075BE	1	534206000
IC13-14	IC 4051B MULTIPLEXER RCA ONLY	02735	CD4051BE	2	534209000
P2	(G) CONNECTOR 6 PIN RT ANG MOD	04901	47733100A	1	47733100A
R1	RES VAR 100 OHM 10% 0.5W	73138	72PR100	1	311408000
R2	RES MF 2.67K 1% 1/4W	19701	5043ED2K670F	1	341341000
R3	RES MF 1.00K 1% 1/4W	19701	5043ED1K000F	1	341300000
R4	RES MF 100 OHM 1% 1/4W	19701	5043ED100R0F	1	341200000
R5	RES MF 10.0K 1% 1/4W	19701	5043ED10K00F	1	341400000
R6	RES MF 5.11K 1% 1/4W	19701	5043ED5K110F	1	341368000
R7	RES MF 10.0K 1% 1/4W	19701	5043ED10K00F	1	341400000
R8	RES MF 8.25K 1% 1/4W	19701	5043ED8K250F	1	341388000
R9	RES MF 10.0K 1% 1/4W	19701	5043ED10K00F	1	341400000
R10	RES COMP 3.0M 5% 1/4W	01121	CB3055	1	343646000
R11	RES VAR 50K 10% 0.5W	73138	72PR50K	1	311393000
R12-13	RES MF 1.00M 1% 1/4W	14674	5043ED1M000F	2	341600000
R14	RES MF 237K 1% 1/4W	19701	5043ED237K0F	1	341536000
R15	RES MF 249K 1% 1/4W	19701	5043ED249K0F	1	341538000
R16	RES MF 12.1K 1% 1/4W	19701	5043ED12K10F	1	341408000
R17	RES MF 806K 1% 1/4W	19701	5043ED806K0F	1	341587000
R18-19	RES COMP 12M 5% 1/4W	01121	CB1265	2	343708000
R20	RES MF 1.82K 1% 1/4W	19701	5043ED1K820F	1	341325000
R21	RES MF 20.0K 1% 1/4W	19701	5043ED20K00F	1	341429000
R22	RES MF 221K 1% 1/4W	19701	5043ED221K0F	1	341533000
R23	RES MF 1.00M 1% 1/4W	14674	5043ED1M000F	1	341600000
R25	RES MF 1.00M 1% 1/4W	14674	5043ED1M000F	1	341600000
R26-28	RES MF 100K 1% 1/4W	19701	5043ED100K0F	3	341500000
R30	RES MF 100K 1% 1/4W	19701	5043ED100K0F	1	341500000
R32	RES MF 9.09K 1% 1/4W	19701	5043ED9K090F	1	341392000
R34	RES MF 10.0K 1% 1/4W	19701	5043ED10K00F	1	341400000
R35	RES MF 5.11K 1% 1/4W	19701	5043ED5K110F	1	341368000
R36	RES VAR 10K 10% 0.5W	73138	72PR10K	1	311328000
R37	RES MF 3.92K 1% 1/4W	19701	5043ED3K920F	1	341357000
R38	RES MF 7.87K 1% 1/4W	19701	5043ED7K870F	1	341386000
R39	RES MF 80.6K 1% 1/4W	19701	5043ED80K60F	1	341487000
R40	RES MF 806K 1% 1/4W	19701	5043ED806K0F	1	341587000
R42	RES MF 7.50K 1% 1/4W	19701	5043ED7K500F	1	341384000
R44	RES VAR 200K 10% 0.5W	73138	72PR200K	1	311401000
R45	RES VAR 10K 10% 0.5W	73138	72PR10K	1	311328000
R47	RES MF 3.92K 1% 1/4W	19701	5043ED3K920F	1	341357000
R48	RES MF 909K 1% 1/4W	19701	5043ED909K0F	1	341592000
R49-52	RES MF 47.5K 1% 1/4W	19701	5043ED47K50F	4	341465000
R53	RES MF 100K 1% 1/4W	19701	5043ED100K0F	1	341500000
R54	RES MF 200K 1% 1/4W	19701	5043ED200K0F	1	341529000
R55	RES VAR 10K 10% 0.5W	73138	72PR10K	1	311328000
RT1	THERMISTOR 50 OHM 10%	00241	LB15J1-M	1	325007000
X14	SOCKET IC 6 PIN	06776	ICN-063-S3TG	1	473054000
XAR4-7	SOCKET IC 8 PIN	06776	ICN-083-S3-G	4	473041000
XIC1	SOCKET IC 40 PIN	06776	ICN-406-S4-TG	1	473052000
XIC2	SOCKET IC 24 PIN	06776	ICN-246-S4-G	1	473043000
XIC6	SOCKET IC 16 PIN	06776	ICN-163-S3-G	1	473042000
XIC9-10	SOCKET IC 14 PIN	06776	ICN-143-S3-G	2	473019000

6-2. Replaceable Parts (Continued)

Section VI
Parts List042361000 OPCODE: 0 REV: AA (G) INPUT REST. NETWORK ASSY
MODEL: 4200

REFERENCE DESIGNATOR	DESCRIPTION	FED. CODE	MANUFACTURER PART NUMBER	QTY	BEC PART NUMBER
R29	RES MF 110K 1% 1/3W	19701	5063JD110K0F	1	338504000
R31	RES MF 110K 1% 1/3W	19701	5063JD110K0F	1	338504000
R33	RES MF 2.10K 1% 1/3W	19701	5063JD2K100F	1	338331000

04222502A OPCODE: 0 REV: A* CHOPPER MODULE
MODEL: 4200

REFERENCE DESIGNATOR	DESCRIPTION	FED. CODE	MANUFACTURER PART NUMBER	QTY	BEC PART NUMBER
A4	PWA CHOPPER DUROID	04901	04216102A	1	04216102A

04216102A OPCODE: 0 REV: A* PWA CHOPPER DUROID
MODEL: COMMON

REFERENCE DESIGNATOR	DESCRIPTION	FED. CODE	MANUFACTURER PART NUMBER	QTY	BEC PART NUMBER
C1-2	CAP PP 0.1uF 10% 100V	27735	PP11-.1-10-100	2	234148000
IC1	(G) IC SELECTED QUAD SWITCH	04901	534223000	1	534223000
P1	TERMINAL .040 OD .270 LG .062M	98291	229-1071-230	1	510038000
P2/1-2/2	CONNECTOR PIN	71279	460-1521-02-03-00	2	477400000
R3	RES MF 51.1K 1% 1/4W	19701	5043ED51K10F	1	341468000
R4-5	RES VAR 25K 10% 0.5W	73138	72PR25K	2	311400000
R6	RES MF 51.1K 1% 1/4W	19701	5043ED51K10F	1	341468000
XIC1	SOCKET IC 14 PIN	91506	714AG10	1	473056000

042360000 OPCODE: 0 REV: A* (G) CALIBRATOR ASSY 4200
MODEL: 4200

REFERENCE DESIGNATOR	DESCRIPTION	FED. CODE	MANUFACTURER PART NUMBER	QTY	BEC PART NUMBER
A3(4)	(G) PWA CALIBRATOR	04901		1	04222700B
C6	CAP FT 1000pF 20% 500V	TUSONX	2499-003-X5S0102M	1	227105000
J1	CONNECTOR HOUSING	27264	22-01-2021	1	479415000
J2	CONNECTOR TYPE "N"	24931	25JR109-3	1	479219000

Section VI
Parts List

6-2. Replaceable Parts (Continued)

04222700B
MODEL: 4200

OPCODE: 0 REV: CC (G) PWA CALIBRATOR

REFERENCE DESIGNATOR	DESCRIPTION	FED. CODE	MANUFACTURER PART NUMBER	QTY	BEC PART NUMBER
AR1	IC 301A OP AMP	27014	LM301AN	1	535012000
C1	CAP CER 470pF 10% 500V	33883	TYPE JF	1	224219000
C2	CAP MICA 100pF 5% 300V	20307	DM5-FC101J	1	205006000
C3	CAP EL 10uF 20% 25V	S4217	SM-25-VB-10-M	1	283336000
C4	CAP VAR CER 3.5-18pF 250V	91293	9373	1	281011000
C5	CAP CER 1000pF 10% 600V	16546	CE-102	1	224310000
C7	CAP EL 10uF 20% 25V	S4217	SM-25-VB-10-M	1	283336000
C8	CAP CER 0.01uF 100V	33883	BT 25U	1	224119000
C9	CAP MICA 36pF 5% 300V	14655	CD5EC360J	1	205003000
C10	CAP MICA 200pF 5% 100V	14655	CD5FA201J	1	205024000
C11	CAP MICA 10pF 5% 300V	14655	CD5WCC100J	1	205002000
C12	CAP VAR CER 3.5-18pF 250V	91293	9373	1	281011000
CR1-2	DIODE HSCH1001 (1N6263)	28480	HSCH-1001	2	530174000
CR3	DIODE MV-1650	04713	MV1650	1	530762000
IC1	IC AD581JH VOLT REF	51640	AD581JH	1	535053000
L1	INDUCTOR 4.7uH 10%	24226	10/471	1	400384000
L2	INDUCTOR 0.56uH 10%	24226	10/560	1	400382000
L3	INDUCTOR 0.033uH 10%	04901	400386000	1	400386000
Q1	TRANS NPN 2N3904	04713	2N3904	1	528071000
R1	RES MF 1.50K 1% 1/4W	19701	5043ED1K500F	1	341317000
R2-3	RES MF 100K 1% 1/4W	19701	5043ED100K0F	2	341500000
R4	RES VAR 1K 10% 0.5W	32997	3299X-1-102	1	311410000
R6	RES MF 100K 1% 1/4W	19701	5043ED100K0F	1	341500000
R7	RES MF 2.43K 1% 1/4W	19701	RN55D-2431-F	1	341337000
R8-9	RES MF 1.00K 1% 1/4W	19701	5043ED1K000F	2	341300000
R10	RES MF 10.0K 1% 1/4W	19701	5043ED10K00F	1	341400000
R11	RES MF 5.11K 1% 1/4W	19701	5043ED5K110F	1	341368000
R12	RES MF 1.21K 1% 1/4W	19701	5043ED1K210F	1	341308000
R13	RES MF 1.30K 1% 1/4W	19701	5043ED1K300F	1	341311000
R14	RES MF 75.0 OHM 1% 1/4W	19701	5043ED75R00F	1	341184000
R15	RES MF 50 OHM 0.1% 1/4W	64537	PME55-T0	1	325916000

04223100C
MODEL: 4200

OPCODE: 0 REV: D* (G) PWA POWER SUPPLY

REFERENCE DESIGNATOR	DESCRIPTION	FED. CODE	MANUFACTURER PART NUMBER	QTY	BEC PART NUMBER
A13(2)	(G) HEAT SINK ASSEMBLY	04901	04223200B	1	04223200B
AR1	IC 339 QUAD COMPARATOR	27014	LM339N	1	535018000
C1-2	CAP EL 2200uF -10%+50% 35V	57582	KSM-2200-35	2	283351000
C3	CAP EL 4700uF -10%+50% 16V	S4217	SM-25-VB-100-M	1	283352000
C4	CAP EL 10uF 20% 25V	S4217	SM-25-VB-10-M	1	283336000
C5-6	CAP EL 100uF 20% 25V	S4217	SM-25-VB-100-M	2	283334000
C7	CAP EL 1000uF -10%+50% 10V	56289	513D108M010DG4	1	283329000
C9	CAP CER 3300pF 10% 100V	61637	C052K332K1X5CA	1	224296000
C9	CAP EL 100uF 20% 25V	S4217	SM-25-VB-100-M	1	283334000
CR1	DIODE BRIDGE KBP-02	15281	KBP02	1	532013000
CR2	DIODE BRIDGE VS-248 6A 200 PIV	27777	VS-248	1	532014000
CR3-6	DIODE SIG 1N4001	04713	1N4001	4	530151000
IC1	IC 78L05 VOLT REG	07263	uA78L05AWC	1	535044000
IC6	IC 4013B DUAL FLIP FLOP	02735	CD4013BE	1	534205000
P1	HEADER 5 PIN STRAIGHT	06383	MPSS156-5-D	1	477345000
P4-5	CONNECTOR 6 PIN STRAIGHT POLAR	27264	22-04-2061	2	477327000
P7-10	CONNECTOR 6 PIN STRAIGHT POLAR	27264	22-04-2061	4	477327000

6-2. Replaceable Parts (Continued)

Section VI
Parts List04223100C OPCODE: 0 REV: D* (G) PWA POWER SUPPLY
MODEL: 4200

REFERENCE DESIGNATOR	DESCRIPTION	FED. CODE	MANUFACTURER PART NUMBER	QTY	BEC PART NUMBER
R1	RES MF 10.0K 1% 1/4W	19701	5043ED10K00F	1	341400000
R2	RES MF 4.99K 1% 1/4W	19701	5043ED4K990F	1	341367000
R3	RES MF 2.21K 1% 1/4W	19701	5043ED2K210F	1	341333000
R4	RES MF 12.7K 1% 1/4W	19701	5043ED12K70F	1	341410000
R5	RES VAR 500 OHM 10% 0.5W	73138	72PR500	1	311305000
R6-8	RES MF 4.99K 1% 1/4W	19701	5043ED4K990F	3	341367000
R9	RES MF 1.00K 1% 1/4W	19701	5043ED1K000F	1	341300000
R10	RES MF 453 OHM 1% 1/4W	19701	5043ED453R0F	1	341263000
R11	RES VAR 100 OHM 10% 0.5W	73138	72PR100	1	311408000
R12	RES MF 464 OHM 1% 1/4W	19701	5043ED464R0F	1	341264000
R13	RES MF 100K 1% 1/4W	19701	5043ED100K0F	1	341500000
R14	RES COMP 330 OHM 5% 1W	01121	G83315	1	302087000
R15	RES MF 5.11K 1% 1/4W	19701	5043ED5K110F	1	341368000
R16	RES MF 2.21K 1% 1/4W	19701	5043ED2K210F	1	341333000
R17	RES MF 2.80K 1% 1/4W	19701	5043ED2R8000F	1	341343000
R18	RES MF 5.11K 1% 1/4W	19701	5043ED5K110F	1	341368000
R19	RES MF 51.1K 1% 1/4W	19701	5043ED51K10F	1	341468000

04223200B OPCODE: 0 REV: 8D (G) HEAT SINK ASSEMBLY
MODEL: 4200

REFERENCE DESIGNATOR	DESCRIPTION	FED. CODE	MANUFACTURER PART NUMBER	QTY	BEC PART NUMBER
IC2	IC 78MGUIC VOLT REG POS	07263	uA78MGUIC	1	535042000
IC3	IC 79MGUIC VOLT REG NEG	07263	uA79MGUIC	1	535043000
IC4	IC 78GUIC VOLT REG	07263	uA78GUIC	1	535055000
IC5	IC 79MGUIC VOLT REG NEG	07263	uA79MGUIC	1	535043000

46528900B OPCODE: 0 REV: AD (G) SWITCH CABLE UNIT
MODEL: 4200

REFERENCE DESIGNATOR	DESCRIPTION	FED. CODE	MANUFACTURER PART NUMBER	QTY	BEC PART NUMBER
S1	SWITCH ROCKER DPDT	13812	572-2121-0103-010	1	465286000

04235601A OPCODE: 0 REV: C* (G) REAR PANEL UNIT
MODEL: 4200-S16

REFERENCE DESIGNATOR	DESCRIPTION	FED. CODE	MANUFACTURER PART NUMBER	QTY	BEC PART NUMBER
P7	CONNECTOR LINE CORD	82389	EAC309	1	477281000
S2	SWITCH DUAL SLIDE DPDT-DPDT	82389	47206LFR	1	465279000

Section VI
Parts List

6-2. Replaceable Parts (Continued)

04235501A OPCODE: 0 REV: B* (G) REAR PANEL ASSY
MODEL: 4200-S16

REFERENCE DESIGNATOR	DESCRIPTION	FED. CODE	MANUFACTURER PART NUMBER	QTY	BEC PART NUMBER
F1	FUSE 0.3 AMP 250V MDL	54426	MDL 0.3	1	545507000
J10	CONNECTOR 5 CIRCUIT	06383	CE156F24-5-C	1	479394000
J15	CONNECTOR PIN FEMALE	27264	0206-1231	1	479320000
J20	CONN COAX BNC	54420	UG-625/U	1	479123000
T1	TRANSFORMER POWER	04901	44609100A	1	44609100A

04231701B OPCODE: 4 REV: EC (G) PWA INTERFACE 4200-01A OPT
MODEL: 4200

REFERENCE DESIGNATOR	DESCRIPTION	FED. CODE	MANUFACTURER PART NUMBER	QTY	BEC PART NUMBER
C1	CAP TANT 1.0uF 10% 35V ONLY	56289	1960105X9035HA1	1	283216000
C2-3	CAP EL 10uF 20% 25V	54217	SM-25-VB-10-M	2	283336000
CR1	DIODE SIG 1N914	01295	1N914	1	530058000
J1	CONNECTOR 24 PIN (GPIB)	32575	552230-1	1	479350000
P2	(G) CONNECTOR 5 PIN RT ANG MOD	04901	47733300A	1	47733300A
R1	RES NETWORK 4.7K 2% 1.8W	01121	3168472	1	345020000
S1	SWITCH SLIDE DIP SPST X 7	75378	206-7-LP	1	46530007A
U1	IC EPORM PROG. 3228G 4200-01A	04901	53432200H	1	53432200H
U2	IC 74LS32 QUAD 2 INPUT OR	01295	SN74LS32H	1	534168000
U3	IC 74LS04 HEX INVERTER	01295	SN74LS04H	1	534155000
U4	IC 9914ANL IEEE BUS PROCESSOR	01295	TMS9914ANL	1	534288000
U5	IC 74LS373 OCTAL LATCH	01295	SN74LS373H	1	534237000
U6	IC 75160 IEEE BUS TRANSCEIVER	01295	SN75160BN	1	534286000
U7	IC 75161 IEEE BUS TRANSCEIVER	01295	SN75161BN	1	534287000
XS1	SOCKET IC 8 PIN	91506	508-AG7D	1	473053000
XU1	SOCKET IC 24 PIN	06776	ICN-246-S4-G	1	473043000
XU4	SOCKET IC 40 PIN	06776	ICN-406-S4-TG	1	473052000
XU5-7	SOCKET IC 20 PIN	06776	ICN-203-S3-G	3	473065000

04223500A OPCODE: 4 REV: E9 PWA INTERFACE 4200-01B OPT
MODEL: 4200

REFERENCE DESIGNATOR	DESCRIPTION	FED. CODE	MANUFACTURER PART NUMBER	QTY	BEC PART NUMBER
A	CONNECTOR 2 PIN STRAIGHT	27264	22-03-2021	1	477361000
B	SHUNT 2 CIRCUIT	27264	15-38-1024	1	483253000
B	CONNECTOR 2 PIN STRAIGHT	27264	22-03-2021	1	477361000
C1	CAP MICA 47pF 5% 300V	20307	DM5-EC470J	1	205018000
C2	CAP TANT 10uF 10% 35V	56289	1960106X9035FE4	1	283353000
C3	CAP CER 0.1uF 20% 50V	04222	SR215E104MAA	1	234268000
C6	CAP EL 10uF 20% 25V	54217	SM-25-VB-10-M	1	283336000
C7-12	CAP CER 0.1uF 20% 50V	04222	SR215E104MAA	6	234268000
J2	CONNECTOR 24 PIN (GPIB)	32575	552230-1	1	479350000
P1	(G) CONNECTOR 5 PIN RT ANG MOD	04901	47733300A	1	47733300A
R1	RES MF 1.00M 1% 1/4W	14674	5043ED1N000F	1	341600000
R2	RES MF 20.5 OHM 1% 1/4W	19701	5043ED20R50F	1	341130000
R3-4	RES MF 4.75K 1% 1/4W	19701	5043ED4K750F	2	341365000
RA1	RES NETWORK 4.7K 2% 1.8W	01121	3168472	1	345020000
RA2	RES NETWORK 22K 2% 1.7W	01121	4088223	1	34504412A

6-2. Replaceable Parts (Continued)

Section VI
Parts List04223500A OPCODE: 4 REV: EB PWA INTERFACE 4200-01B OPT
MODEL: 4200

REFERENCE DESIGNATOR	DESCRIPTION	FED. CODE	MANUFACTURER PART NUMBER	QTY	BEC PART NUMBER
S1	SWITCH DIP SPST 3 CKT PIANO	LAMB	BT-8-2	1	46529908A
U1-2	IC 82C55 INTERFACE	34371	CP82C55A	2	53441100A
U3-4	IC 74HC04 HEX INVERTER	02735	CD74HC04E	2	53442504A
U5	IC 7705 SUPPLY VOLTAGE SUPVR	01295	TL7705ACP01295	1	53442200A
U6	IC 74HC74 DUAL D TYPE FLO	02735	CD74HC74E	1	53442502A
U7	IC 2800 CPU CMOS	TOSHIB	TMP284C00AP	1	53440900A
U8	IC EPROM PROG 452AA 4200	04901	53445200A	1	53445200A
U9-10	IC 74HC32 QUAD 2 INPUT OR	02735	CD74HC32E	2	53442501A
U11	IC 5564 8Kx8 RAM CMOS 28 DIP	TOSHIB	TC5564PL-15	1	534403000
U12	IC 74HC139 DUAL 2-4	02735	CD74HC139E	1	53442500A
U15	IC 74HC240 OCTAL BUS	02735	CD74HC240E	1	53442503A
U16	IC 9914ANL IEEE BUS PROCESSOR	01295	TMS9914ANL	1	534288000
U17	IC 75160 IEEE BUS TRANSCEIVER	01295	SN75160BH	1	534288000
U18	IC 75161 IEEE BUS TRANSCEIVER	01295	SN75161BH	1	534287000
XU1-2	SOCKET IC 40 PIN	06776	ICN-406-84-TG	2	473052000
XU3-4	SOCKET IC 14 PIN	06776	ICN-143-83-G	2	473019000
XU5	SOCKET IC 8 PIN	06776	ICN-083-83-G	1	473041000
XU6	SOCKET IC 14 PIN	06776	ICN-143-83-G	1	473019000
XU7	SOCKET IC 40 PIN	06776	ICN-406-84-TG	1	473052000
XU8	SOCKET IC 28 PIN	06776	ICN-286-84-TG	1	473044000
XU9-10	SOCKET IC 14 PIN	06776	ICN-143-83-G	2	473019000
XU11	SOCKET IC 28 PIN	06776	ICN-286-84-TG	1	473044000
XU12	SOCKET IC 16 PIN	06776	ICN-163-83-G	1	473042000
XU14	SOCKET IC 24 PIN	06776	ICN-246-84-G	1	473043000
XU15	SOCKET IC 20 PIN	06776	ICN-203-83-G	1	473065000
XU16	SOCKET IC 40 PIN	06776	ICN-406-84-TG	1	473052000
XU17-18	SOCKET IC 20 PIN	06776	ICN-203-83-G	2	473065000
Y1	CRYSTAL 3.579545 MHz	EDMAR	MQC035A	1	547033000

99100614C OPCODE: 0 REV: A* 4200-01B
MODEL: 4200

REFERENCE DESIGNATOR	DESCRIPTION	FED. CODE	MANUFACTURER PART NUMBER	QTY	BEC PART NUMBER
IC6A5	IC EPROM PROG 450AA 4200	04901	53445000A	1	53445000A
IC7A5	IC EPROM PROG 451AA 4200	04901	53445100A	1	53445100A

04223002B OPCODE: 0 REV: D* PWA INPUT-03 OPT
MODEL: 4200

REFERENCE DESIGNATOR	DESCRIPTION	FED. CODE	MANUFACTURER PART NUMBER	QTY	BEC PART NUMBER
-------------------------	-------------	--------------	-----------------------------	-----	--------------------

Same as standard PWA Input P/N 04423002B

Section VI
Parts List

6-2. Replaceable Parts (Continued)

04232002A OPCODE: 3 REV: D- REAR INPUT 4200-04 OPT
MODEL: 4200

REFERENCE DESIGNATOR	DESCRIPTION	FED. CODE	MANUFACTURER PART NUMBER	QTY	BEC PART NUMBER
<401>	CAP AND CHAIN	02660	80-75-CCC1	1	477155000
<402>	CABLE CLIP 1/8"	06915	HUC-2	1	810099000
<403>	CABLE CLAMP 1/4"	06915	HUC-4	1	810100000
<404>	SCREW 4-40 X 1/4 BH SS SEMS			1	911002000
<405>	NUT HEX 5/8-27 X 3/32 X 3/4	02660	41-16	1	745270000
<406>	WASHER LOCK 5/8 INT	78189	1228-02	1	843038000
<407>	(G) CONNECTOR ASSY FEMALE	04901	09214101C	1	09214101C
<408>	PLATE CONN UNIT	04901	72088600A	1	72088600A
<409>	PLUG BUTTON 5/8"	83330	654	1	755107000
<410>	CABLE INPUT	04901	571157000	1	571157000
<411>	SHIELD	04901	81211900C	1	81211900C

99100624C OPCODE: 0 REV: B* 4200-01B-06 OPT
MODEL: 4200

REFERENCE DESIGNATOR	DESCRIPTION	FED. CODE	MANUFACTURER PART NUMBER	QTY	BEC PART NUMBER
IC6A5	IC EPROM PROG 427AA 4200	04901	53442700A	1	53442700A
IC7A5	IC EPROM PROG 428AA 4200	04901	53442800A	1	53442800A
U8A23	IC EPROM PROG 429AA 4200	04901	53442900A	1	53442900A
U14A23	IC 82C54 TIMER	34371	CP82C54	1	53441000A

SECTION VII SCHEMATIC DIAGRAMS

Schematic Diagrams		Page
7-1	Main Frame A1, Schematic Diagram	7-3
7-2	Display Board A2, Schematic Diagram	7-5
7-3	Power Reference Board A3, Schematic Diagram	7-7
7-4	Chopper Board A4, Schematic Diagram	7-9
7-5	Control Board A5, Schematic Diagram (Sheet 1 of 2)	7-11
7-5	Control Board A5, Schematic Diagram (Sheet 2 of 2)	7-13
7-6	Input Module Board A6, Schematic Diagram (Sheet 1 of 2)	7-15
7-6	Input Module Board A6, Schematic Diagram (Sheet 2 of 2)	7-17
7-7	Power Supply Board A7, Schematic Diagram	7-19
7-8	Options, Schematic Diagram	7-21

A1 MAIN FRAME

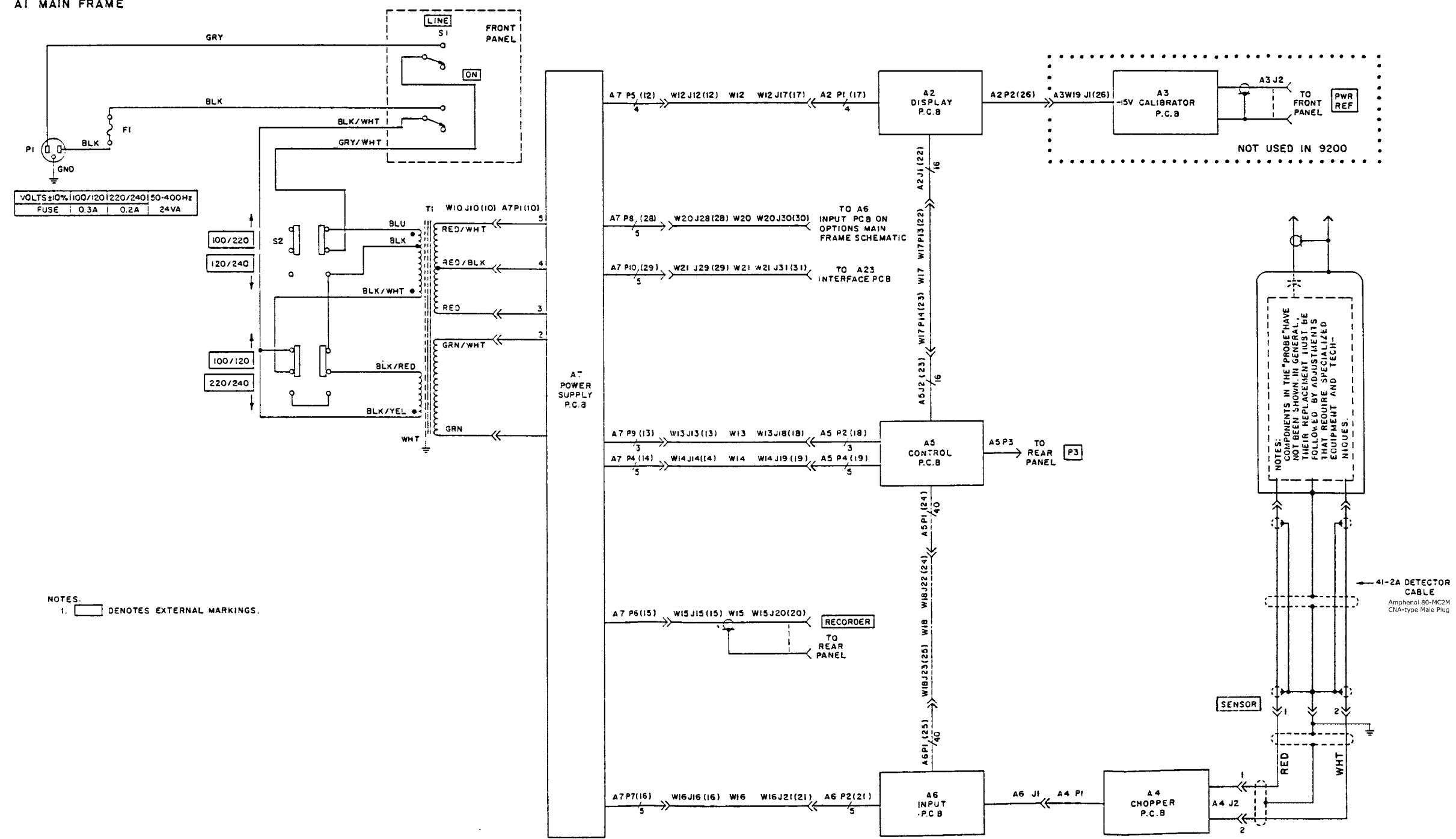

E831271B

Figure 7-1 Main Frame A1, Schematic Diagram

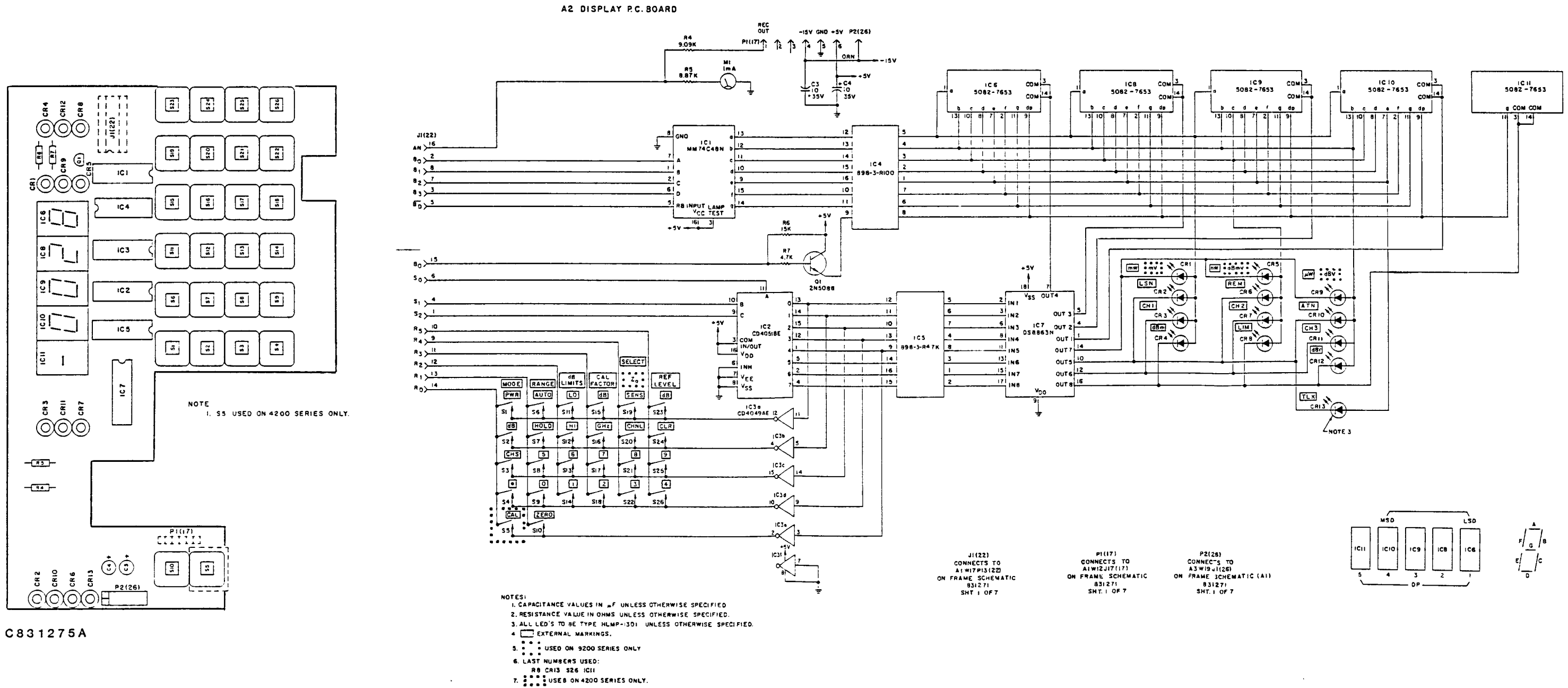

C831275A

E831271B

Figure 7-2 Display Board A2, Schematic Diagram

B831274A

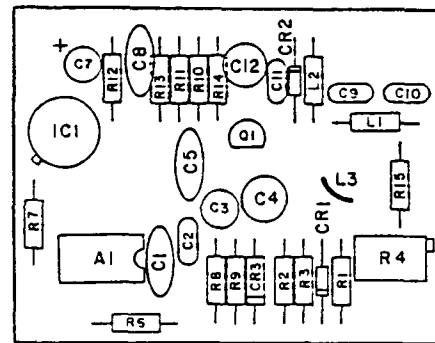

B831274A

D831271A

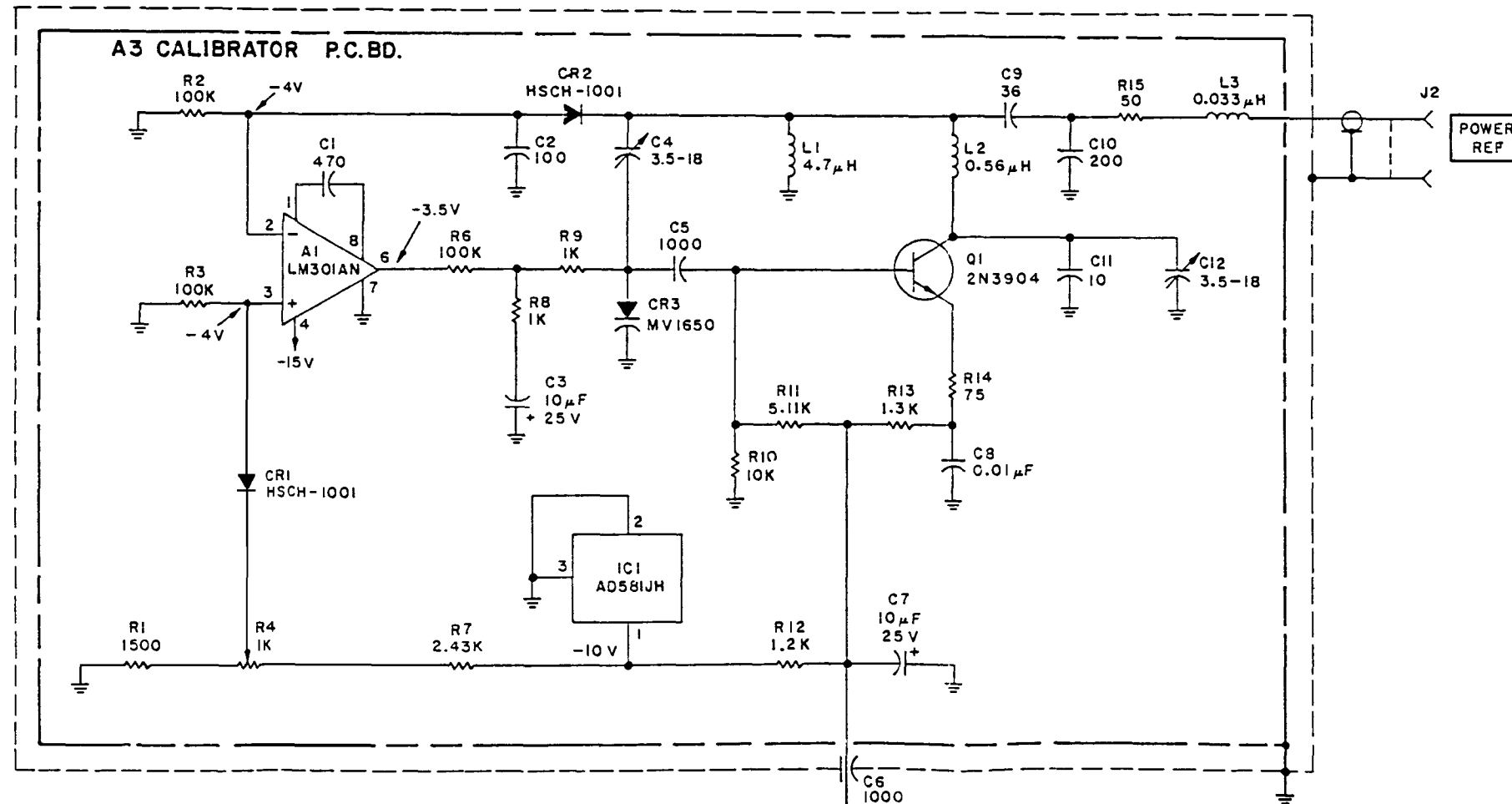

NOTES:

1. CAPACITANCE VALUES IN pF, UNLESS OTHERWISE SPECIFIED.
2. RESISTANCE VALUES IN OHMS.
3. EXTERNAL MARKINGS.
4. LAST NUMBERS USED:
C12 R15
5. NUMBERS NOT USED:
R5

J1 (26)
ORN
-15V

J1 (26)
CONNECTS TO
A2 P2 (26)
ON FRAME SCHEMATIC
831271
SHT. 1 OF 7

D831271A

Figure 7-3 Power Reference Board A3.
Schematic Diagram

A4 CHOPPER P. C. BD.

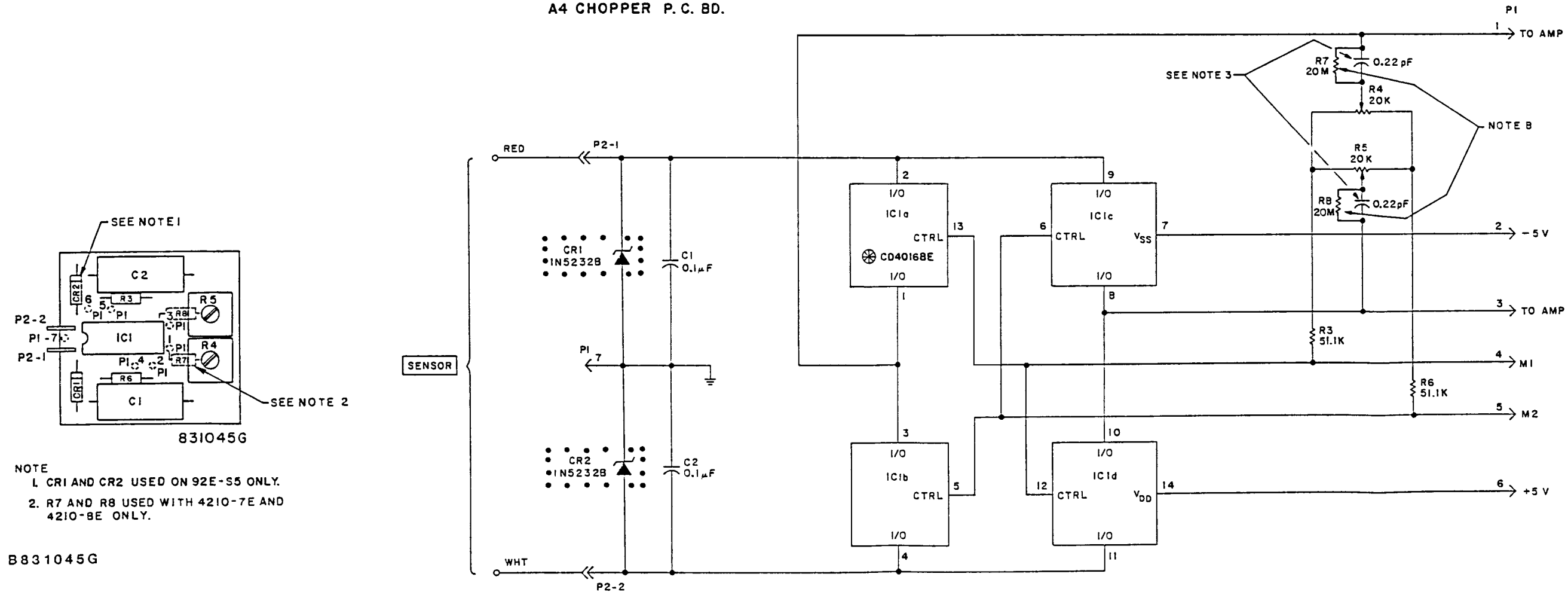

P1
CONNECTS TO
A6J1
ON FRAME SCHEMATIC
831271
SHT. 1 OF 7
AND
A6 J1
ON OPTION FRAME
SCHEMATIC
B31099
AND
A2 J2
ON FRAME SCHEMATIC
B31170
SHT. 1 OF 3

NOTE
1. CR1 AND CR2 USED ON 92E-S5 ONLY.
2. R7 AND R8 USED WITH 4210-7E AND
4210-8E ONLY.

B831045G

NOTES:

1. RESISTANCE VALUES IN OHMS.
2. FACTORY SELECTED.
3. CAPACITANCE IS PART OF P.C. BD. CIRCUITRY.
4. EXTERNAL MARKING.
5. LAST NUMBERS USED:
R8
6. NUMBERS NOT USED:
R1, R2
7. USED ON 92E-S5 ONLY.
8. RES R7, R8 USED ONLY WITH 4210-7E
AND 4210-8E SENSORS.

D831271D

SCHEMATIC, CHOPPER P.C. BD.
D831271D SHT. 4 OF 7

Figure 7-4 Chopper Board A4. Schematic Diagram

A5 CONTROL P.C. BOARD

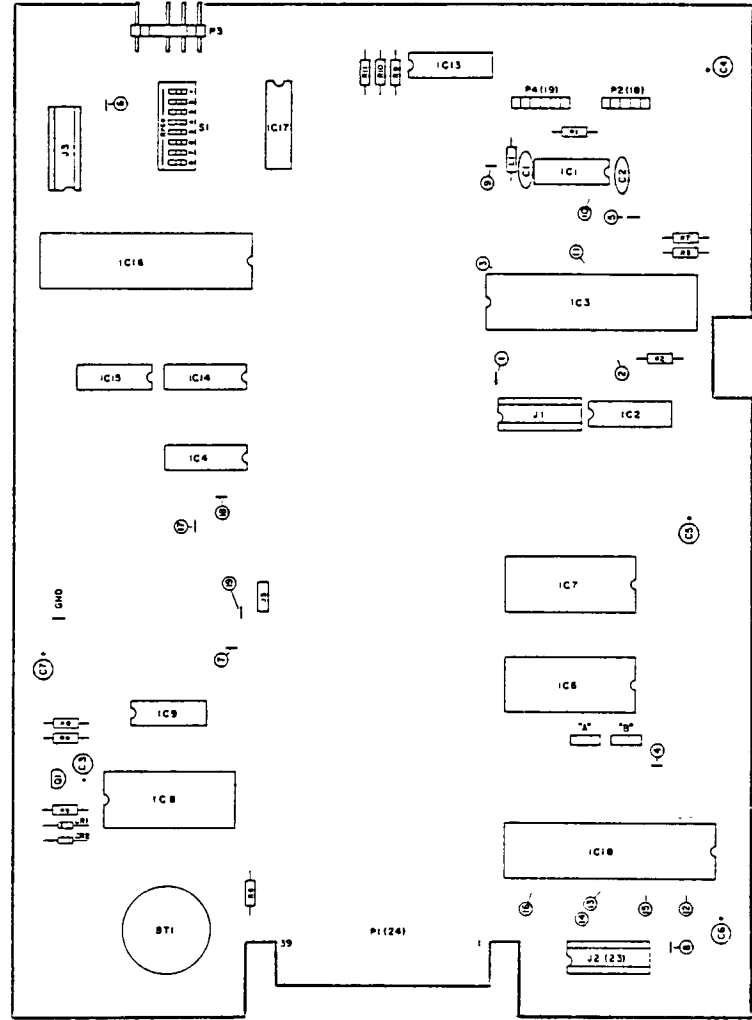

D 83 1299D

- NOTES:
1. CAPACITANCE VALUES IN μ F, UNLESS OTHERWISE SPECIFIED.
 2. EXTERNAL MARKINGS.
 3. LAST NUMBERS USED.
C7 IC18 R11
 4. TEST POINT
 5. NUMBERS NOT USED:
IC5, IC10, IC11, IC12

D 83 1271C
Sh 6

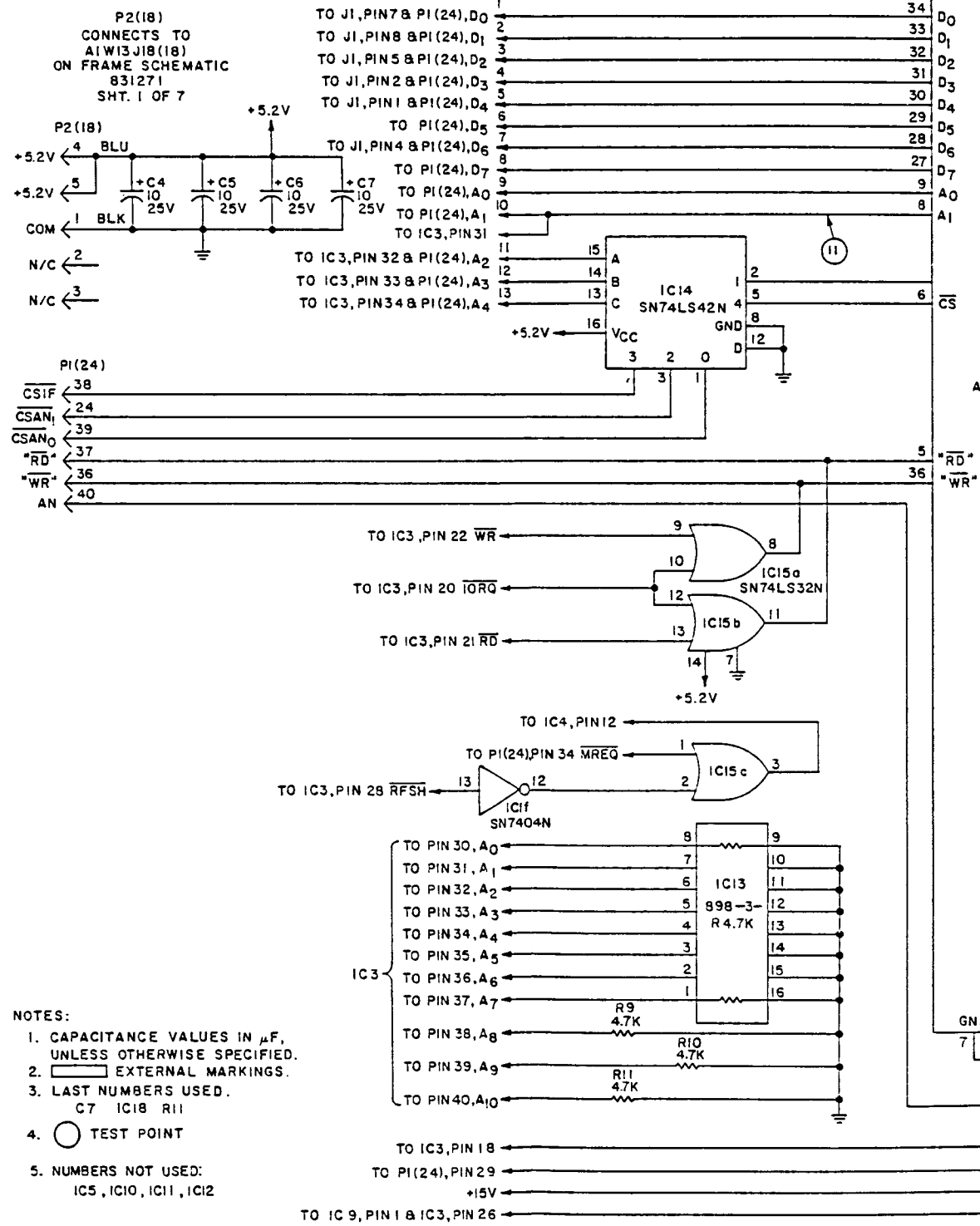

J2(23)
CONNECTS TO
AIW17PI4(23)
ON FRAME SCHEMATIC
83J271
SHT. 1 OF 9

P4(19)
CONNECTS TO
AIW14J19(19)
ON FRAME SCHEMATIC
83J271
SHT. 1 OF 9

SCHEMATIC, CONTROL P.C. BD.
D831271C SHT. 6 OF 9

Figure 7-5 Control Board A5.
Schematic Diagram (Sheet 1 of 2)

A5 CONTROL P.C. BOARD

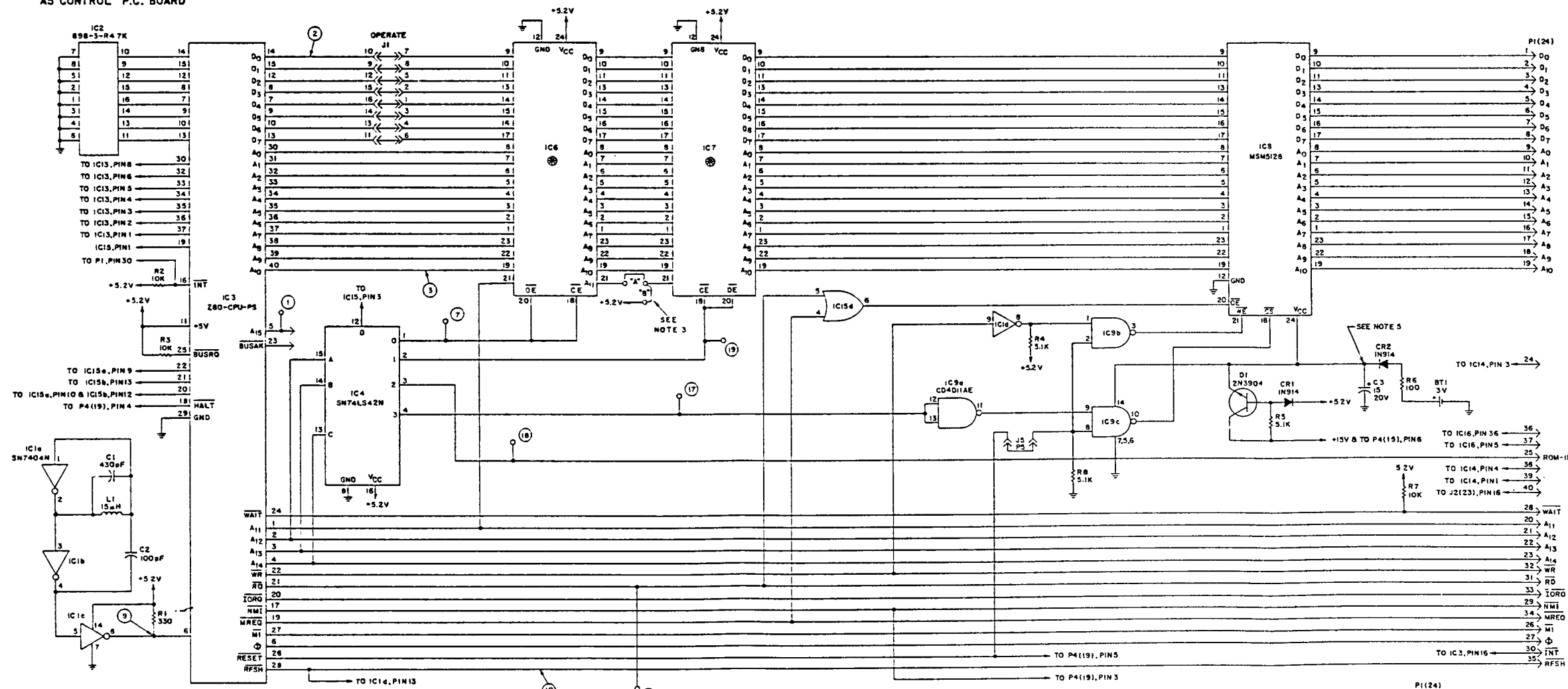

- NOTES:
1. CAPACITANCE VALUES IN μ F, UNLESS OTHERWISE SPECIFIED.
 2. RESISTANCE VALUES IN OHMS
 3. USE JUMPER "A" WHEN IC7 IS A 32K ROM
USE JUMPER "B" WHEN IC7 IS A 16K ROM
 4. LAST NUMBERS USED:
R8 C3 IC12
 5. UNIT ON = 5.2V, UNIT OFF NOM. = 2.8V.
 6. ○ TEST POINT
 7. ⊗ SELECTED COMPONENT
 8. NUMBERS NOT USED:
IC5, IC10, IC11, IC12

P1(24)
CONNECTS TO
A1 W18 J22 (24)
ON FRAME SCHEMATIC
831271
SHT 1 OF 7
AND
CONNECTS TO
A20 W20 J24 (24)
ON OPTIONS FRAME
SCHEMATIC
831099

SCHEMATIC, CONTROL P.C. BD.
E831271B SHT. 5a OF 7

Figure 7-5 Control Board A5,
Schematic Diagram (Sheet 2 of 2)

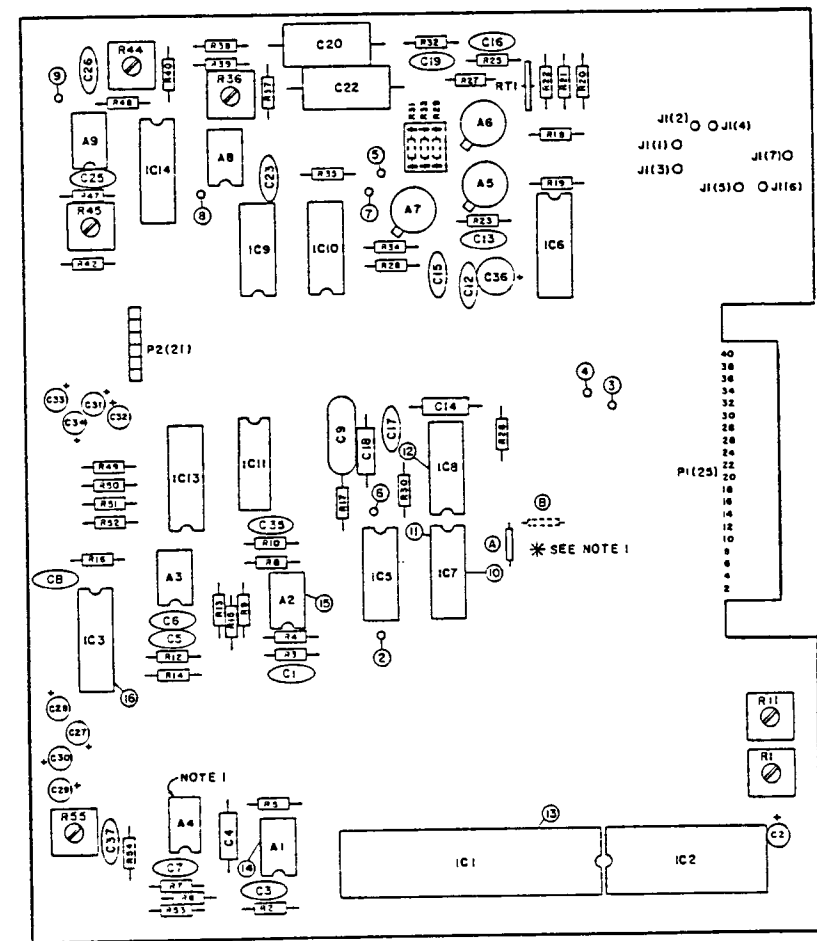

NOTES:
1. * CHANNEL 1 ADD JUMPER (B).
CHANNEL 2 ADD JUMPER (A).
REMOVE (B) & A4 AMPLIFIER.

D831276B

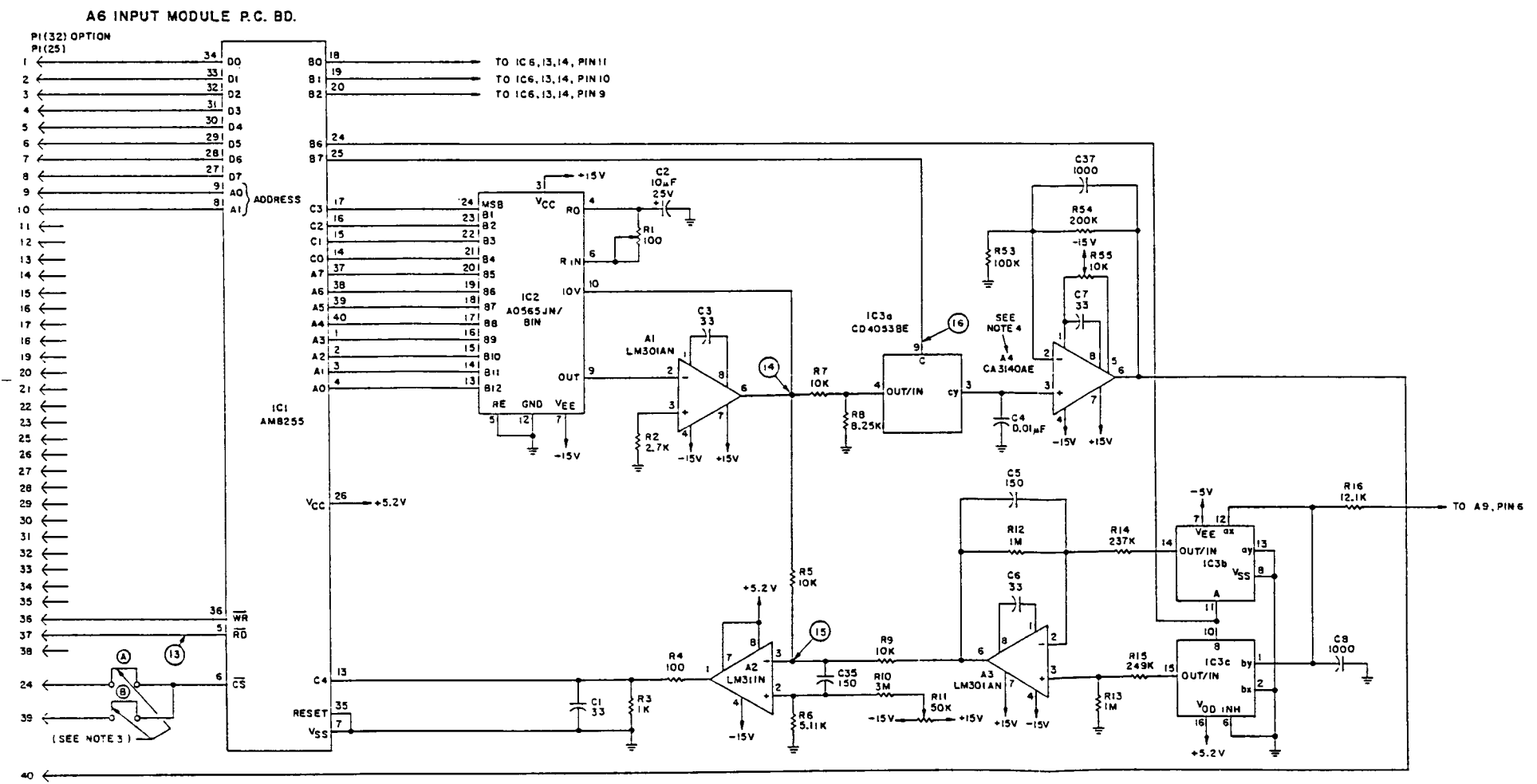
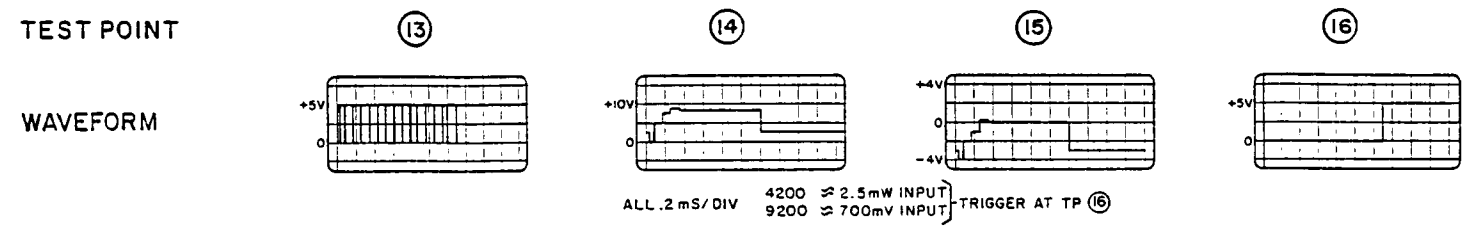

NOTES:
1. CAPACITANCE VALUES IN pF, UNLESS OTHERWISE SPECIFIED.
2. RESISTANCE VALUES IN OHMS, UNLESS OTHERWISE SPECIFIED.
3. CHANNEL 1 ADD JUMPER (B) ONLY. CHANNEL 2 ADD JUMPER (A). REMOVE (B).
4. A4 NOT USED ON CHANNEL 2.
5. ○ TEST POINT

PI(25) CONNECTS TO A1W18J23(25) ON FRAME SCHEMATIC 831271 SHT. 1 OF 9

PI(32) CONNECTS TO A20W20J29(32) ON OPTION FRAME SCHEMATIC 831099

SCHEMATIC, INPUT MODULE P.C. BD. D831271A SHT. 7 OF 9

D831271A
Sh 7

Figure 7-6 Input Module Board A6.
Schematic Diagram (Sheet 1 of 2)

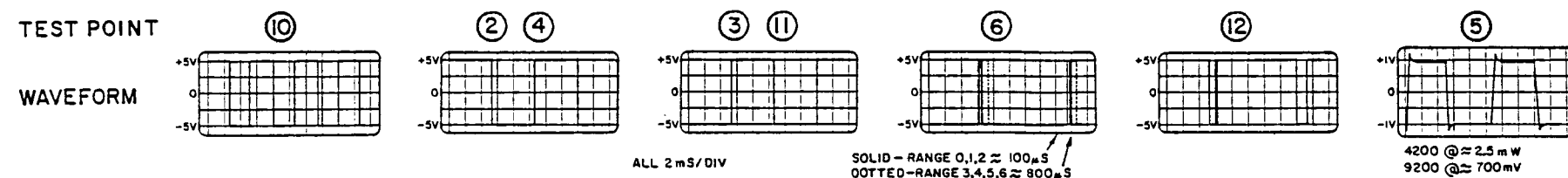

A6 INPUT MODULE P.C.BD.

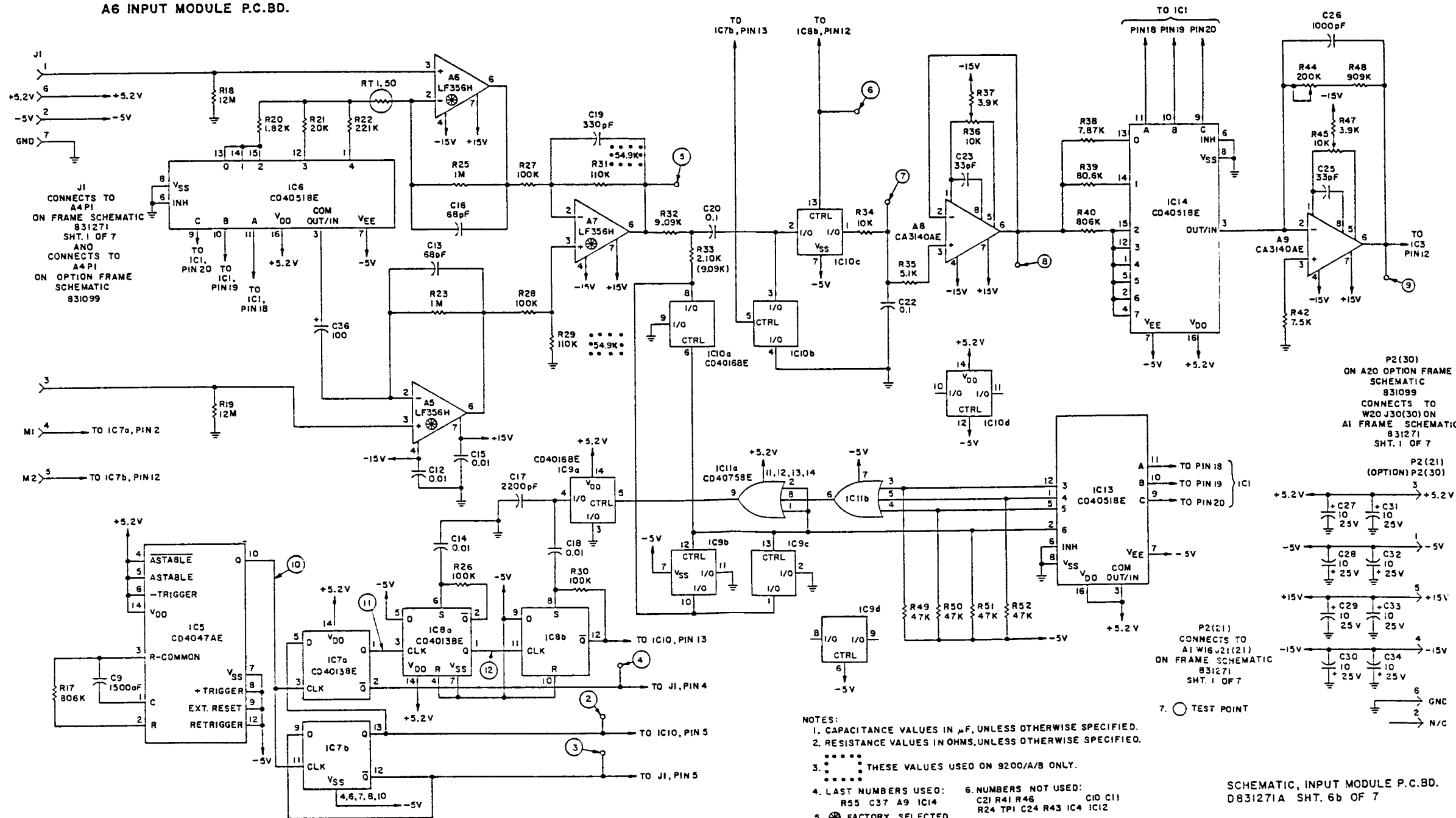

D831271A
Sh 6b

Figure 7-6 Input Module Board A6,
Schematic Diagram (Sheet 2 of 2)

A7 POWER SUPPLY P.C. BD.

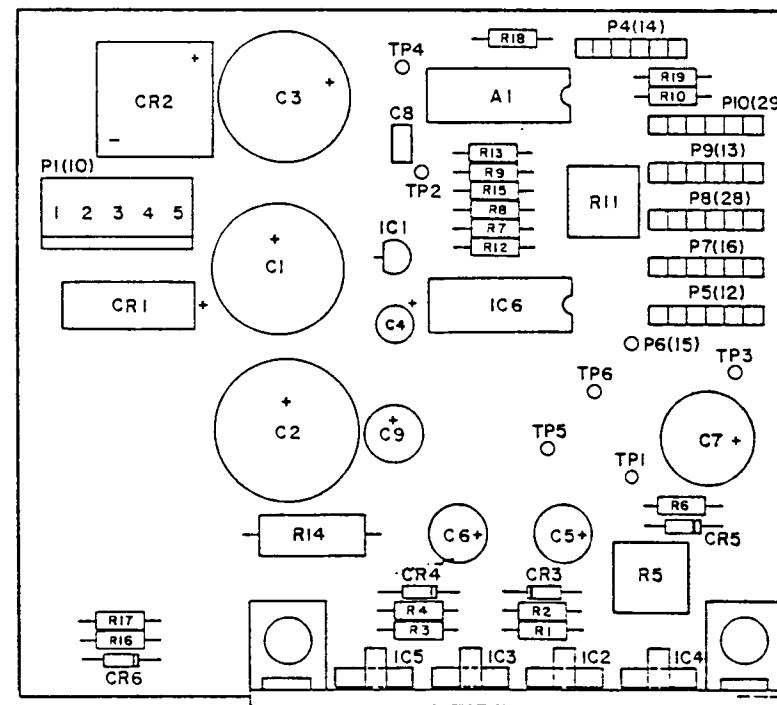

C831273B

C831273B

E831271A

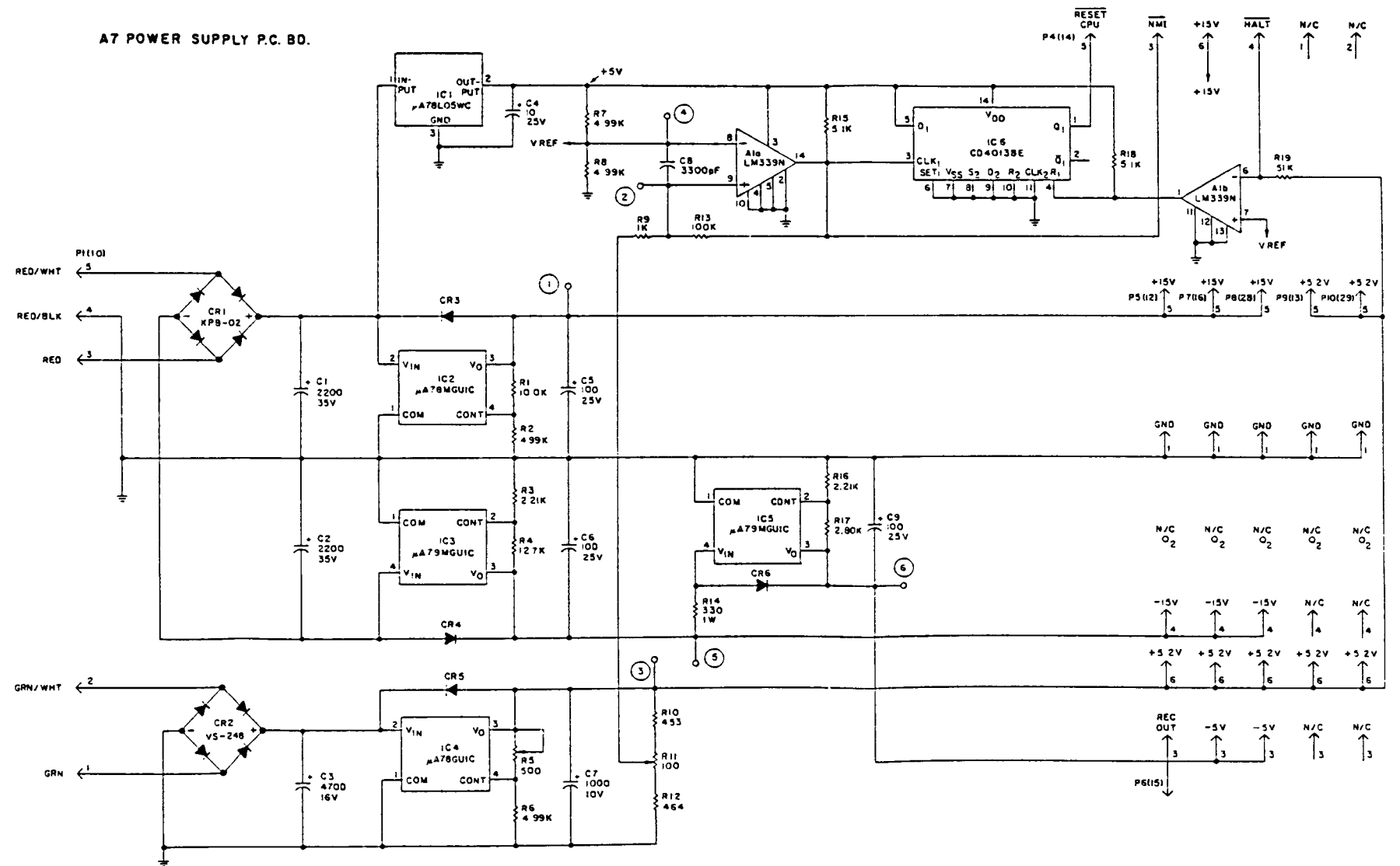

P1 (10)
CONNECTS TO
A1 J10 (10)
ON FRAME SCHEMATIC
831271
SHT. 1 OF 7

P5 (12)
CONNECTS TO
A1 W12 J12 (12)
ON FRAME SCHEMATIC
831271
SHT. 1 OF 7

P7 (16)
CONNECTS TO
A1 W16 J16 (16)
ON FRAME SCHEMATIC
831271
SHT. 1 OF 7

P9 (13)
CONNECTS TO
A1 W13 J13 (13)
ON FRAME SCHEMATIC
831271
SHT. 1 OF 7

P4 (14)
CONNECTS TO
A1 W14 J14 (14)
ON FRAME SCHEMATIC
831271
SHT. 1 OF 7

P6 (15)
CONNECTS TO
A1 W15 J15 (15)
ON FRAME SCHEMATIC
831271
SHT. 1 OF 7

P8 (28)
CONNECTS TO
A1 W20 J28 (28)
ON FRAME SCHEMATIC
831271
SHT. 1 OF 7

P10 (29)
CONNECTS TO
A1 W21 J29 (29)
ON FRAME SCHEMATIC
831271
SHT. 1 OF 7

- NOTES.
- 1 ALL CAPACITANCE VALUES IN μ F, UNLESS OTHERWISE SPECIFIED
 - 2 ALL RESISTANCE VALUES IN OHMS
 - 3 ○ TEST POINT
 - 4 LAST NUMBERS USED
R18 C9
 - 5 NUMBERS NOT USED
P2 P3

Figure 7-7 Power Supply Board A7.
Schematic Diagram

E831271A

E831099D

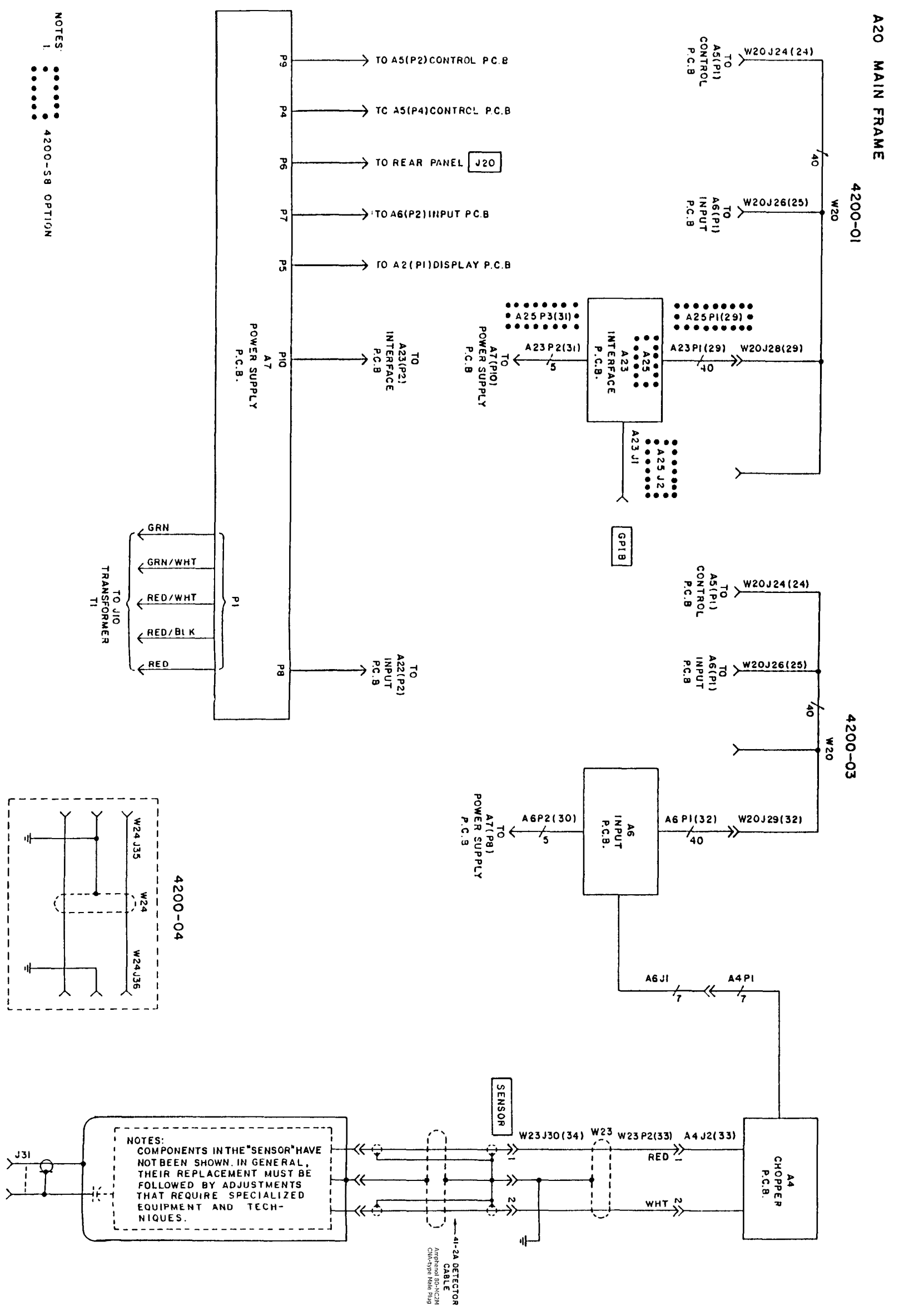

E831099D

NOTES:
 1. 4200-58 OPTION

Figure 7-8 Options. Schematic Diagram

APPENDIX A
IEEE-488 BUS INTERFACE
OPTION 4200-01A

A-1. DESCRIPTION.

A-2. The IEEE-488 (GPIB) bus interface option permits external control of the instrument and data capture by a wide variety of compatible controllers. The instrument may be operated with other GPIB-compatible devices to achieve specific test automation goals, with no specialized control interface requirements for proper electrical operation.

A-3. Although no standard GPIB interface data formats have yet been established, certain common practices are achieving de-facto standard status. These practices have been adhered to in the design of the 4200-01A option interface formats and delimiters, thereby assuring the user of format compatibility with almost all controllers.

A-4. CAPABILITY.

A-5. Certain subsets of full GPIB functions are specified in the IEEE-488 1978 Standard. The Model 4200-01A option includes the following capabilities:

- SH1 SOURCE HANDSHAKE complete capability
- AH1 ACCEPTOR HANDSHAKE complete capability
- T6 BASIC TALKER, SERIAL POLL, UNADDRESS IF MLA, NO TALKER ONLY capability
- TE0 NO EXTENDED TALKER capability
- L4 BASIC LISTENER, UNADDRESS IF MTA, NO LISTENER ONLY capability
- LE0 NO EXTENDED LISTENER capability
- SR1 SERVICE REQUEST capability
- RL1 REMOTE-LOCAL capability, LOCAL LOCKOUT capability
- PP0 NO PARALLEL POLL capability
- DC0 NO DEVICE CLEAR capability
- DT1 DEVICE TRIGGER capability
- C0 NO CONTROLLER capability

MLA = My Listen Address
MTA = My Talk Address

A-6. INSTALLATION.

A-7. Option 4200-01A consists of interface board A23. Electrical interconnections are shown in Figure 7-8. To install the interface board, proceed as follows:

- a. Turn off power to the instrument.
- b. Remove the screws that secure the top cover of the instrument and slide the top cover back and off.

c. Cut the cable tie in the instrument that holds the extra power plug (the plug with two blue wires and one black wire).

d. Remove the six screws that fasten the control board and replace them with the six mounting posts supplied with the -01B package.

e. Position the interface board in the instrument so that the mounting holes in the interface board line up with the mounting posts in the instrument. Attach the interface board to the mounting posts with six 4-40 screws and lockwashers supplied with the interface board.

f. Connect the 40 pin ribbon connector to the front edge connector of the interface board.

g. Connect the power plug in the instrument to the 4-pin brown connector on the interface board.

A-8. OPERATION.

A-9. Address Assignment. Before using the instrument in the GPIB, it must be assigned a unique address. This address is set using the five right-most sections of rear-panel address switch S1 in accordance with Table A-1.

A-10. Message Terminator. Positions 6 and 7 of the rear-panel switch S1 permit a choice of message terminators, as shown in Table A-2.

A-11. Command Response. In addition to Talk and Listen Address commands, the instrument responds to the following:

a. Address Commands (Response if Listen Addressed).

Mnemonic	Name	Function
GTL	Go To Local	Enables panel control
GET	Group Execute Trigger	Trigger a measurement

b. Listen Address Group.

Mnemonic	Name	Function
UNL	Unlisten	De-address as listener

c. Talk Address Group.

Mnemonic	Name	Function
UNT	Untalk	De-address as talker

TABLE A-1. ADDRESS ASSIGNMENT						
*Decimal Address	Talk Code	Listen Code	Switch Setting			
			5	4	3	2 1
0	@	SP	0	0	0	0 0
1	A	!	0	0	0	0 1
2	B	"	0	0	0	1 0
3	C	#	0	0	0	1 1
4	D	\$	0	0	1	0 0
5	E	%	0	0	1	0 1
6	F	&	0	0	1	1 0
7	G	'	0	0	1	1 1
8	H	(0	1	0	0 0
9	I)	0	1	0	0 1
10	J	*	0	1	0	1 0
11	K	+	0	1	0	1 1
12	L	,	0	1	1	0 0
13	M	-	0	1	1	0 1
14	M	.	0	1	1	1 0
15	N	/	0	1	1	1 1
16	O	0	1	0	0	0 0
17	P	1	1	0	0	0 1
18	Q	2	1	0	0	1 0
19	R	3	1	0	0	1 1
20	S	4	1	0	1	0 0
21	T	5	1	0	1	0 1
22	U	6	1	0	1	1 0
23	V	7	1	0	1	1 1
24	X	8	1	1	0	0 0
25	Y	9	1	1	0	0 1
27		;	1	1	0	1 1
28	\	<	1	1	1	0 0
29		=	1	1	1	0 1
30	^	>	1	1	1	1 0

*Address 31 (11111) will not be recognized and should not be used.

TABLE A-2. MESSAGE-TERMINATOR SELECTION		
Switch		Message Terminator
7	6	
0	0	EOI
0	1	CR*
1	0	LF*
1	1	CR LF*

*With or without EOI

A-11. (Continued).

d. Unencoded Commands.

Mnemonic	Name	Function
IFC	Interface Clear	Initialize Interface
REN	Remote Enable	Permits remote operation

A-12. Operating States. The instrument operates in two separate states, whether in local or remote control. One state is the measurement state, during which the instrument performs and displays measurements; the other state is the data entry/recall state, which is operative during number entry or after recall of stored information. When operating on the bus, it is important to remember that the instrument can send only that information which appears on the front panel display. When the instrument is in the store or recall mode, the LED display and annunciators blink on and off to indicate that the displayed value is not a measured value.

a. Measurement Mode Functions. The following functions change the measurement mode of the instrument:

Keyname	GPIB	Function
PWR MODE	P	Displays measured voltage
dB MODE	B	Displays measured dBmV

b. Command Functions. Table A-3 describes command functions.

Keyname	GPIB	Function
dB CAL FAC	D	Cal Factor Constant, 1n dB
RANGE AUTO	A	Sets autorange mode
RANGE HOLD	O	Sets range hold mode
GHz	F	Interpolates Freq/Cal Factor Table

TABLE A-3. COMMAND FUNCTIONS			
Command	Arm	Disarm	Description
Q	1Q	0Q	Hold command: the last reading, or the last keyboard entry, will remain on the display. The instrument will continue to read probe input, but will not update the display. The instrument cycle time will be greatly reduced because of the measurement-cycle overhead that is not executed during the hold command.
V	1V	0V	Service request command: the service request will be issued by the instrument upon completion of a measurement.
J	1J	0J	Raw-data command: the instrument will not average or smooth any of the measurements.
U	1U	0U	Limit command: the instrument will issue a service request if any limit is exceeded. If a limit is exceeded and a service request is issued, the U command must be rearmed to become operational again.
T			Trigger command: this command, identical with the IEEE-488 group execute trigger, initiates a measurement cycle.

INTERFACE CLEAR and DEVICE disarm all the above commands.

A-12. (Continued).

c. Service Request Status Codes. Service request status is defined by a five-bit code, as defined in Table A-4.

TABLE A-4. SERVICE REQUEST STATUS					Meaning
BIT					
4	3	2	1	0	
X	X	X	0	1	CH 1 low limit exceeding
X	X	X	1	0	Ch 1 high limit exceeding
X	0	1	X	X	Ch 2 low limit exceeding
X	1	0	X	X	Ch 2 high limit exceeding

d. Data Entry/Recall Functions. These functions enable entry or retrieval of numeric constants used by the instrument. Operation reverts to the measuring state after data storage.

Keyname	GPiB	Function
LIMITS dB LO	L	Low limit value in dB
LIMITS dB HI	H	High limit value in dB
SELECT CHNL	N	Selects channel number
dB REF LEVEL dB	R	dB reference level for dB modes
SENS	S	Selects Sensor Data Tables

e. Special Functions. Special functions include the automatic zeroing and clear functions.

Keyname	GPiB	Function
ZERO	Z	Initiate an automatic zeroing cycle
CLR	C	Clear numeric entry to zero
CAL	K	Performs 1 mW Auto Calibration

f. IEEE-488 Bus Command Extensions. The following functions are added to bus operation:

Name	GPiB	Function
ADR.ZERO	Y	Zero selected ranges (0-7)
SET RANGE	G	Set to selected range (0-7)

These commands must be preceded by an appropriate argument. The argument for Y is the span of ranges to be zeroed; for example: 26Y specifies zeroing of ranges 2 through 6. If only one range is to be zeroed, the argument must begin and end with the same code (e.g., 11Y to zero only range 1). The argument for G is the range number (0 = 10 nW to 6 = 10 nW for 4200-4 sensors) to be set. From execution of the Y command to measurement mode, the maximum time is as follows:

A-12. (Continued).

Command	Time	Command	Time
00Y	2.3 seconds	04Y	3.8 seconds
01Y	2.9 seconds	05Y	4.0 seconds
02Y	3.3 seconds	06Y	4.3 seconds
03Y	3.5 seconds		

The "Y" command allows no wait time for a sensor to reach a stable zero before actual offset storage occurs.

NOTE

The G command sets the 4200 to an internal range which may not correspond to the range code output in the data string in Paragraph B-21. The table below relates internal and apparent range codes:

LEVEL	INTERNAL	APPARENT
+10 dB	10 mW	-
		6
+6 dB	3.98 mW	-
0 dB	1 mW	6 -
		5
-10 dB	100 μW	-
-11 dB	79.4 μW	- 5 -
		4
-20 dB	10 μW	-
-21 dB	7.94 μW	- 4 -
		3
-30 dB	1 μW	-
-32 dB	631 nW	- 3 -
		2
-40 dB	100 nW	-
		- 2 -
-42 dB	63.1 nW	-
		1
-50 dB	10 nW	-
-52 dB	6.31 nW	- 10
-60 dB	1 nW	0
		↓
		↓

For the series 4 and 5 sensors add 10 dB to the internal and apparent levels.

For the series 6 sensor add 20 dB to the internal and apparent levels.

g. Bus Availability. When the Model 4200 is sent a string, it does not normally tie up the bus while responding to the string; other bus communications are possible during the interval. The 4200 can inform the controller when it is finished by use of the Service Request see paragraph B-12d, if this is desired.

The Model 4200 can, however, be made to lock up the bus while it is responding to a string - if such action is desired - by sending it two strings in succession (even if the second string is only a Null command).

Example: A "zero" command: wrt 716,"Z"
Followed by a "talk" command: red 716,A,B,C

A-13. TIME RESPONSE CHART.

Refer to Tables 1-3 for the Model 4200 sensor measurement through the IEEE-488 Bus.

A-14. REMOTE PROGRAMMING.

NOTE

It is assumed that the user is acquainted with GPIB principles and terminology. Refer to the controller instruction manual for the syntax needed to create specific bus commands and addressing sequences. All examples given apply to the HP 9825 calculator.

A-15. Bus Programming Syntax. The bus programming syntax mirrors the front-panel keystroke sequence closely. Each key has been assigned an alphanumeric character and sending that character is equivalent to pressing that front-panel key. The resulting operation is indistinguishable from local control. Numerical values are translated by the GPIB interface so that commonly observed formats may be used. Fixed formats and floating point formats may both be used. These representations are converted to their equivalent fixed point values and the sign information is post-fixed automatically, thereby ensuring that natural notations for numbers will be accepted by the instrument.

A-16. Suppose that it is desired to set the instrument to the PWR mode. The HP 9825 calculator could be programmed:

wrt 716, "P"

The "wrt" instructs the calculator to send data on the bus to one or more listeners. The number following is the address information; 7 is the calculator address and 16 is the instrument address. (all examples in this appendix will use 16 as the instrument address, although any valid address can be assigned to the instrument.) When the calculator interprets the first part of the line, it will assert the ATN line to signify that commands or addresses will be sent on the bus. Following that, it will send three bytes or characters: Unlisten, the calculator Talk Address and the instrument Listen Address. This information will configure both the calculator and the instrument for the data transfer. After the last command byte has been accepted, ATN will be released to the false state by the calculator. All information on the bus is interpreted as data in this mode. While in the data mode, the calculator will send the character "P" to the instrument. At the instrument, this will be interpreted as equivalent to pressing the MODE PWR key and that function will be executed. Because there is no more data to be sent, the calculator will send a delimiter (the preselected ASCII code for the termination character). The instrument recognizes the termination character as an end-of-message signal and returns to the bus idle condition.

A-17. The preceding discussion of the sending of a single programming byte serves to illustrate two important points: every data transfer is preceded by a command/address preamble and each transfer is terminated by a termination character. In the preceding example, six characters were sent on the bus; only one was a programming byte.

A-18. The measurement mode functions (P, B, A, O) and the special functions (Z, K) do not expect any numeric value. These functions all execute as received. For example: the following will program dB and autorange mode:

```
wrt 716, "BA"
  or
wrt 716, "AB"
```

Note that the sequence is unimportant, except that each function executes in the order it is received on the bus.

A-19. Suppose that the instrument is to be zeroed automatically, and then asked to send the reading in the PWR and RANGE AUTO mode. The HP 9825 calculator could be instructed as follows:

```
wrt 716, "APZ"
red 716, V, S
```

The automatic zeroing cycle time is approximately 10 to 22 seconds, depending on range. Until zeroing is completed, the instrument will be unable to respond with new data. The first line of the preceding instructions sets the operating mode and initiates the zeroing cycle. The last line reads the response from the instrument. The instrument response consists of two numeric values: the first value is the front panel reading and the second is a status value (normally zero). These two numbers will be stored in the calculator variables (storage locations) V and S. Note that each data transmission from the instrument consists of two values. When the status value is non-zero, indicating an error condition, the data value will be set to zero. The program will normally test the status value to assure valid operating conditions.

A-20. Store/Recall Functions Syntax. The general syntax for store/recall functions is the same as the front panel sequence; if a numeric value immediately precedes the function, that value will be stored; otherwise, the existing stored value will be recalled to the front panel. These functions (L, H, D, F, S, N, R, J, U, V) thus operate in a dual mode. When the instrument is in the store or recall mode the display will blink to indicate that the instrument is not in the measurement mode. The instrument is returned to the measurement mode by sending any of the following: P, B, A, O, T, 1J, 0J, 1Q, 0Q, 1V, 0V, 1U or 0U.

A-21. Suppose that it is desired to store the current power level in dBm into the dBm reference so that all future readings will be referenced to the current value. Allowance must be made for the possibility that the

current value is a dB relative value. To do this, the current dB value must be read, the existing dB reference must be recalled, the true dBm value must be computed and this value must be stored into dB reference. The calculator could be instructed as follows:

```
red 716, V, S
wrt 716, "R"
red 716, X, S
V + X → Y
wrt 716, Y, "R"
```

Note that R is used twice in the program, the first time to obtain the existing value for the dB reference and the second time to store the computed value. Also, note that the two read statements (red) each fetch a different value, the first value is the power value in dB and the second is the dB reference.

A-22. Output Data Format. The data output of the instrument consists of two numeric values. The first is the numeric data in the display and the second is the status information. The normal data output will have the following format:

abcdEsd, S, R (tc)

Where:

ab = mode (power in milliwatts = PW;
dB = DM; dBm = DR)

c = channel (A = 1; B = 2; C = 3)

s = sign (+ or -)

ddd = data (four digits, each digit
0-9)

Esd = exponent, sign, digit

, = data delimiter

S = status digit:

- 0 = no error
- 1 = entry too small
- 2 = entry too large
- 3 = measurement under range
- 4 = measurement over range
- 5 = zero acquisition out of range - excessive positive offset
- 6 = zero acquisition out of range - excessive positive offset
- 7 = channel 3 over/under range

R = Range Code, coded per Table A-4

tc = termination character

A-23. Hold Indication Function Syntax. The Hold Indication function, when enabled (1Q), automatically does a measurement cycle following its receipt and then holds the indication until receipt of a T, 0Q or another 1Q command. It is intended primarily for use with the Trigger or Group Execute Trigger commands. Following its receipt, the instrument continues to measure but does not update the display. This can be useful where response time is important since

TABLE A-4. RANGE CODES FOR VARIOUS SENSORS					
Range	Sensor Type				
Code	4200-4E	4200-5E	4200-6E	4200-7E	4200-8E
0	<-50 dBm	<-40 dBm	<-30 dBm	<-20 dBm	<-10 dBm
1	<-40 dBm	<-30 dBm	<-20 dBm	<-10 dBm	< 0 dBm
2	<-30 dBm	<-20 dBm	<-10 dBm	< 0 dBm	
3	<-20 dBm	<-10 dBm	< 0 dBm	<+10 dBm	
4	<-10 dBm	< 0 dBm	<+10 dBm		
5	< 0 dBm	<+10 dBm	<+20 dBm		
6	<+10 dBm	<+20 dBm	<+30 dBm		

A-23. (Continued).

display-update time is eliminated until called for with a Trigger (T) command; another IQ command will also update the display and maintain the hold indication function; a 00 command will update the display and negate the hold indication function.

A-24. SRQ Function Syntax. The controller can command the instrument to pull the SRQ line true after each measurement. The syntax for this command is 1V; to command the instrument not to pull the SRQ line true after each measurement the syntax is 0V.

A-25. Measurement Trigger Syntax. The Trigger (T) command is an addressed command (wrt T16,"T"), used to trigger a measurement, and is generally used in conjunction with the Hold Indication function (Q). (Refer to paragraph B-23.) The instrument is also responsive to the unaddressed Group Execute Trigger (GET) command. This command is asynchronous and may result in a slightly faster response time than the T command, which is executed only once each measurement cycle.

A-26. Limit Service Request. This command, when enabled, will result in a service request by the instrument when either dB limit (high or low) of either channel (channel 1 or channel 2) is exceeded. The limit exceeded and the channel can be determined from the service request byte as shown below:

NOTE

Bit 6, when set, is the service request.

Bit	Limit Exceeded
7 6 5 4 3 2 1 0	
X 1 X X X X 0 1	Channel 1 low limit
X 1 X X X X 1 0	Channel 1 high limit
X 1 X X 0 1 X X	Channel 2 low limit
X 1 X X 1 0 X X	Channel 2 high limit

A-27. Typical Application. Suppose that it is desired to measure insertion loss or gain with an instrument equipped with option 4200-03, channel 2 measures incident power and channel 1 measures output power. The program, shown below, will request reference conditions and wait for the user to set them up. Following establishment of the reference,

the program will loop on insertion loss/gain measurements. Each measurement is triggered by the user. Zeroing is prompted in the local mode at the beginning of the program. Reading errors, should they occur, will be signalled by a double beep from the calculator; normal measurements will give a single beep. There will be one print line per measurement. The reference value is not printed in this example.

Program Variable Usage:

- P: = power measurement value
- R: = range value
- S: = status value
- Z: = dummy input for prompts

Program Statements	Comments
0: cli 7	/clear interface
1: ent "zero chl, 2",Z	/prompt for zeroing
2: rem 7	/enable remote
3: wrt 716, "1NA0R2NA0R3N"	/0 dBref, auto - set ch 3
4: ent "ref measure",Z	/prompt to set up ref
5: red 716,P,S,R	/read ref value, status
6: if S>0;dsp "error",S; beep; goto 4	/test status
7: wrt 716,"1N", P,"R3N"	/set ch 1 dBref = P
8: beep;ent "measure",Z	/prompt for measurement
9: red 716,P,S,R	/read measurement, status
10: if S>0; dsp "error",S; beep;wait 100; goto 8	/test status
11: prt P,"dB"; goto 8	/print measurement
12: end	

A-28. The program in paragraph A-25 also measures reflection coefficient if channel 1 measures reflected power and channel 2 measures incident power. The reference conditions are established with a short at the test port of the directional coupler.

A-29. Use of Hold Measurement (Q), Trigger (T) and Measurement Complete-SRQ (V) Commands. An example of the use of these commands using an HP85 Controller, Boonton Electronics Model 1020 Signal Generator and Model 4200 RF Microwattmeter follows:

Statement	Comment
10 ! TQVCHK	Program name
20 REMOTE 7 @ CLEAR	Enable remote; clear display
30 OUTPUT 703; "1N1SODOROQOVAB"	Set Model 4200; channel 1 sensor 1, 0 CAL FACTOR dB, 0 REFERENCE dB, no hold indication, no measurement-complete SRQ, autorange mode, dB display mode
40 OUTPUT 702; "1MH0LOON"	Set Model 1020; 1 MHz, output level of 0 dBm, output on
50 OUTPUT 703; "1Q"	Set Model 4200 to hold indication mode
60 OUTPUT 702; "0L-10"	Set Model 1020 to -10 dBm level
70 ENTER 703: A	Read model 4200; store in A
80 PRINT A	Print model 4200 indication
90 DISPLAY "PRESS CONTINUE FOR T COMMAND"	Display prompt on Model 85
100 PAUSE @ BEEP	Stop program; issue beep (press continue)
110 OUTPUT 703; "T"	Send T (trigger command) to Model 4200
120 ENTER 703; A	Read model 4200 indication; store in A
130 PRINT A	Print model 4200 indication
140 OUTPUT 703; "OQ"	Set Model 4200 for indication-hold, auto range mode, dB mode
150 DISP"PRESS CONTINUE FOR 1V COMMAND"	Display prompt on Model 85
200 PAUSE @ BEEP	Stop program; issue beep
210 OUTPUT 702; "0L0"	Set Model 1020 to 10 dBm output

220 WAIT 1000	Wait 1 second for settled indication on 4200
230 ON INTR 7 GO TO 290	If interrupt occurs, branch to 290
240 OUTPUT 703; "1V"	Set Model 4200 to issue a SRQ at completion of measurement
250 WAIT 200	Wait 0.2 second
260 ENABLE INTR 7;8	Enable SRQ interrupt in Model 85
270 ON TIMER #L, 5000 GO TO 370	If no interrupt is received in 5 seconds, branch to 370
280 GO TO 280	Wait for interrupt (or escape after 5 seconds - step 270)
290 OUTPUT 703; "OV"	At interrupt, set Model 4200 to no-measurement-complete SRQ
295 WAIT 200	Wait 0.2 seconds
300 S=SPOLL(703)	Store result of serial poll of Model 4200 in S
310 IF BIT(S,6)<>1 THEN GO TO 370	If bit 6 (SRQ bit) of Model 4200 service request byte does not equal 1, go to 370
320 PRINT "MEAS-COMP-SRQ"	If bit 6 does equal 1 (SRQ bit) print "MEAS-COMP-SRQ"
340 DISP"PRESS CONTINUE FOR OV COMMAND"	Display prompt on Model 85
350 PAUSE @ BEEP	Stop program; issue beep
360 GO TO 260	Go to 260
370 PRINT"NO-MEAS-COMP-SRQ"	There has been no service request
380 PRINT "DONE"	Check is complete; print "DONE"

In the above example, the device addresses are:

Device	Address
HP Model 85B	7
BEC Model 1020	2
BEC Model 4200	3

The sequence of events in the above program are as follows:

APPENDIX A
OPTION 4200-01A

A-29. (Continued).

HP85 Controller	Comments
RUN	The model 4200 will read the generator level of approximately 0 dBm and this will be printed by the model 85B; the Model 1020 generator will change its level to -10 dBm but the Model 4200 will not change its indication since it is in the hold-indication mode; program stops at pause and waits for "CONTINUE" on Model HP85.
CONTINUE	This issues a T (trigger) command to the Model 4200 which now changes to approximately -10 dBm; this is printed by the Model HP85.
CONTINUE	This initiates a sequence in which the measurement-complete-SRQ is enabled.
CONTINUE	This initiates a sequence in which the measurement-complete-SRQ has been disabled.

A-30. Model 4200 Device Dependent Statement Summary. Refer to Table A-5.

A-31. Sealed System Operation. When in sealed system operation (selected by the control board bit switch) the instrument will power up in the operate mode but, by the use of the proper GPIB commands this instrument can be placed in the DC or AC modes to allow calibration of the instrument over the bus without removal from the system rack. The GPIB commands are:

Operate Mode	"80m"
Calibrate Mode 1 (DC Cal)	"81m"
Calibrate Mode 2 (AC Cal)	"82m"

A-32. THEORY OF OPERATION.

A-33. General. Interface board A23 is a microprocessor-driven data interface which converts IEEE 488 bus compatible signals into control codes that operate the internal control bus of the instrument. It also converts instrument data into IEEE 488 compatible signals for use on the bus. All data transfers are handled by source and acceptor handshake protocols as defined by IEEE-488-1978.

A-34. Detailed Description. Refer to Figure A-1. All data manipulation and IEEE 488 bus management are controlled by CPU A51C3 on the instrument control board in conjunction with a micro-program stored in PROM A23U1 on the interface board. All data transfer is handled in parallel-to-parallel mode by adapter A23U4. Latch A23U5 handles transfer of bit switch data that defines the instrument address and message termination characters to the instrument data bus.

Bi-directional buffers A23U6 and A23U7 handle data and control signal transfers, respectively, between adapter A23U4 and the interface buses.

A-35. When the instrument is turned on, the RESET line to adapter A23U4 is set low while capacitor A23C1 charges through pull-up network A23U1, thereby clearing the adapter. To initiate an interface transaction, signal RCM-IF is set low by CPU A51C3, thereby enabling the output of PROM A23U1. Interface micro-program instructions from the PROM memory location specified by the address bits from the CPU are written onto the instrument data bus. The CPU executes these instructions and activates the control signals required to perform the commanded interface transaction.

A-36. Instrument address and message termination character data manually preset into bit switch A23S1 is supplied to latch A23U5. To read the switch data, control signals RD and CSTF and address bit A6 are activated, thereby enabling the latch output through gates A23U2c and A23U2b and inverter A23U3c. The switch data is then transferred through the latch to the instrument data bus.

A-37. To read incoming interface control signals, the CPU activates signals RD and CSTF and sets address bit A6 low. The interface control signal port of adapter A23U4 is selected through address bits A0, A1 and A5. Adapter A23U4 is enabled through gate A23U2a. Because signal RD is active, signal TE supplied by the adapter to buffer A23U7 is inactive, and this buffer is set up for data transfer from the interface control signal bus to the control signal port of adapter A23U4. Incoming interface control signals are transferred through buffer A23U7 and adapter A23U4 to the instrument data bus. Clocking of adapter operations is controlled by the clock signal from the instrument control board. Interface control signal transfer in the opposite direction is achieved by reversing the states of signals RD and WR. An active WR causes signal TE to buffer A23U7 to become active, thereby reversing the direction of data flow through the buffer. Interface control signals from the instrument data bus are then written onto the interface control bus through adapter A23U4 and buffer A23U7. Interface control signals are defined as follows:

DAV	DATA VALID
NRFD	NOT READY FOR DATA
NDAC	NOT DATA ACCEPTED
ATN	ATTENTION
IFC	INTERFACE CLEAR
REN	REMOTE ENABLE
SRQ	SERVICE REQUEST
E0I	END OR IDENTIFY

TABLE A-5. MODEL 4200 DEVICE DEPENDENT* STATEMENT SUMMARY

Statement	Description	Statement	Description
T	Trigger a measurement	H	Recall high dB limit
OJ	Enable data averaging	(N)D	Enter N as CAL FACTOR in dB (N = -3.00 to +3.00)
1J	Disable data averaging	D	Recall CAL FACTOR in dB
J	Recall state of J to display (0 or 1)	(N)F	Enter N as frequency as CAL FACTOR GHz determination (N = 0.1 to 999.9)
OU	Disable dB-limit-exceeded service request	F	Recall frequency for CAL FACTOR GHz determination
1U	Enable dB-limit-exceeded service request	(N)S	Enter N as sensor number (N = 1 through 8)
U	Recall state of U to display (0 or 1)	S	Recall sensor number
OV	Disable service request at measurement completion	(M)N	Enter M as channel number (M = 1 through 3)
1V	Enable service request at measurement completion	N	Recall channel number
V	Recall state of V to display (0 or 1)	(N)R	Enter N as dB reference level (N = -99.99 to +99.99)
OQ	Disable display indication hold	R	Recall dB reference level
1O	Enable display indication hold	Z	Initiate automatic zeroing cycle
P	Display measurement in power	K	Perform 1 mW automatic calibration
B	Display measurement in dB	C	Clear numeric entry to 0
A	Enable autorange mode	(NM)Y	Zero ranges N through M (N = 0 through 6; M = 0 through 6; both must be used)
O	Enable hold-range mode	(N)G	Set instrument to range N (N = 0 through 6)
(N)L	Enter N as high dB limit (N = -99.99 to +99.99)		
L	Recall low dB limit		
(N)H	Enter N as high dB limit (N = -99.99 to +99.99)		

*All other commands are controller dependent; see controller instruction manual.

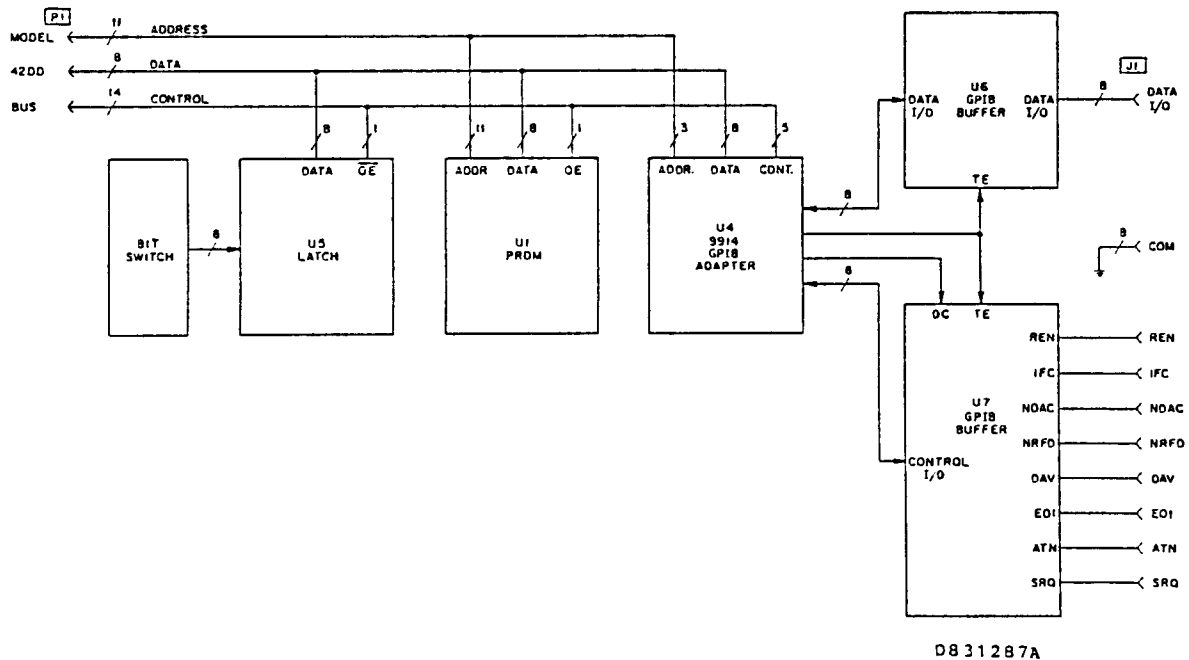

Figure A-1. IEEE-488 Bus Interface Option 4200-01A Block Diagram

A-38. To handle data transfers between the Instrument data bus and the Interface data bus, adapter A23U4 is similarly enabled through gate A23U2a by control signal CSIF and a low address bit A6. Address bits A0, A1 and A5 are set to select the data port of adapter A23U4 and signals WR and RD specify the write and read functions. If data is to be written onto the Interface data bus, signal WR is activated, thereby activating signal TE to buffer A23U6. Data on the Instrument data bus is then transferred through adapter A23U4 and buffer A23U6 to the Interface data bus. For data transfers from the Interface data bus to the Instrument data bus, signal WR is inactive and signal RD is active. Signal TE to buffer A23U6 is deactivated by adapter A23U4 to reverse the direction of data transfer through the buffer.

A-39. MAINTENANCE.

A-40. General. The Interface board does not operate alone, but rather in conjunction with the Model 4200. If Interface operation becomes abnormal it should first be determined if the 4200 operates normally without the Interface. If it does, proceed according to the following paragraphs.

A-41. Physical Inspection. Check the Interface board visually for loose or broken connectors, foreign material, etc.

A-42. Voltage Checks. With the board installed in the 4200, and all connectors in place, check the supply-and-IC-voltages according to the values shown on the schematic diagram, Figure A-2.

A-43. Active-Device Substitution. All the active devices are socketed, making replacement simple. Replace each device, one at a time, and check for restoration of proper performance by the Instrument.

A-44. Troubleshooting. An oscilloscope, while not the most useful tool for troubleshooting bus-oriented microprocessor systems, still may be used to determine activity or lack of activity on the address, data and control lines.

A-45. REPLACEABLE PARTS.

A-46. Table 6-2 lists all the replaceable parts and includes; Reference Symbol, Description, Mfr., Mfr's Part No., and the BEC Part No.

A-47. SCHEMATICS.

A-48. Refer to Figure A2 for the 4200-01A schematic.

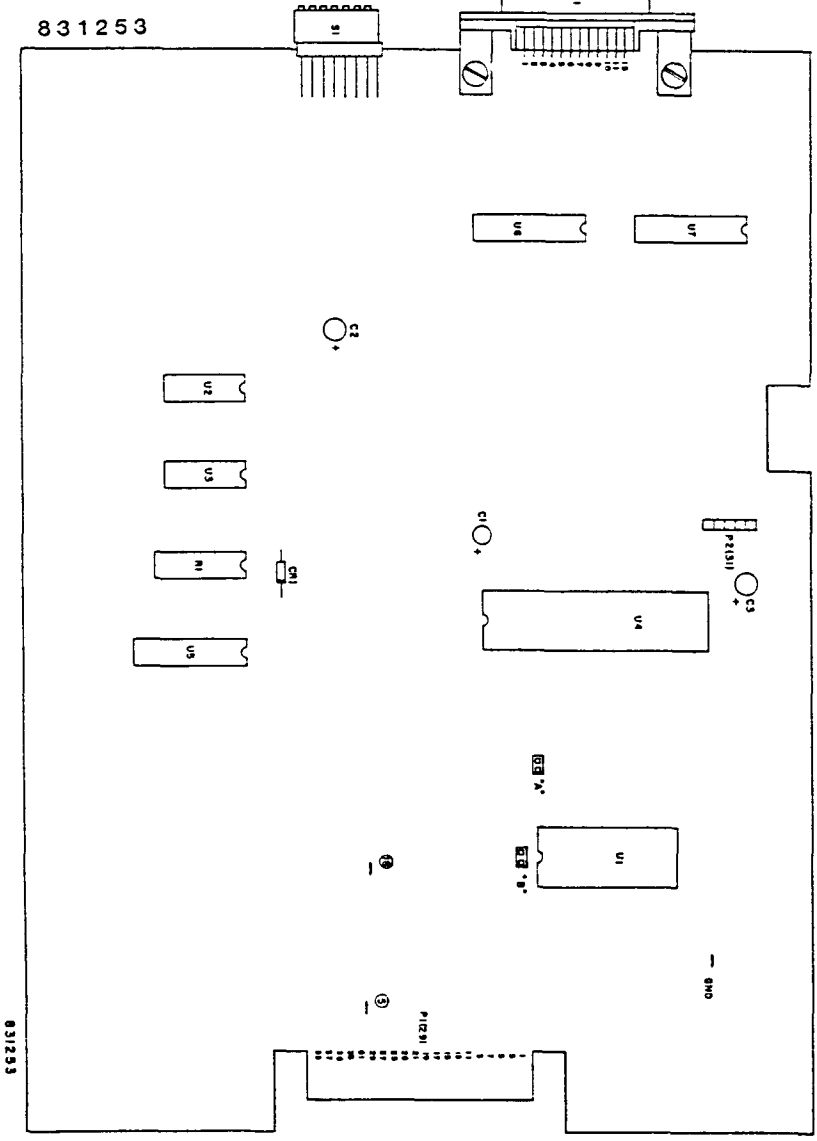
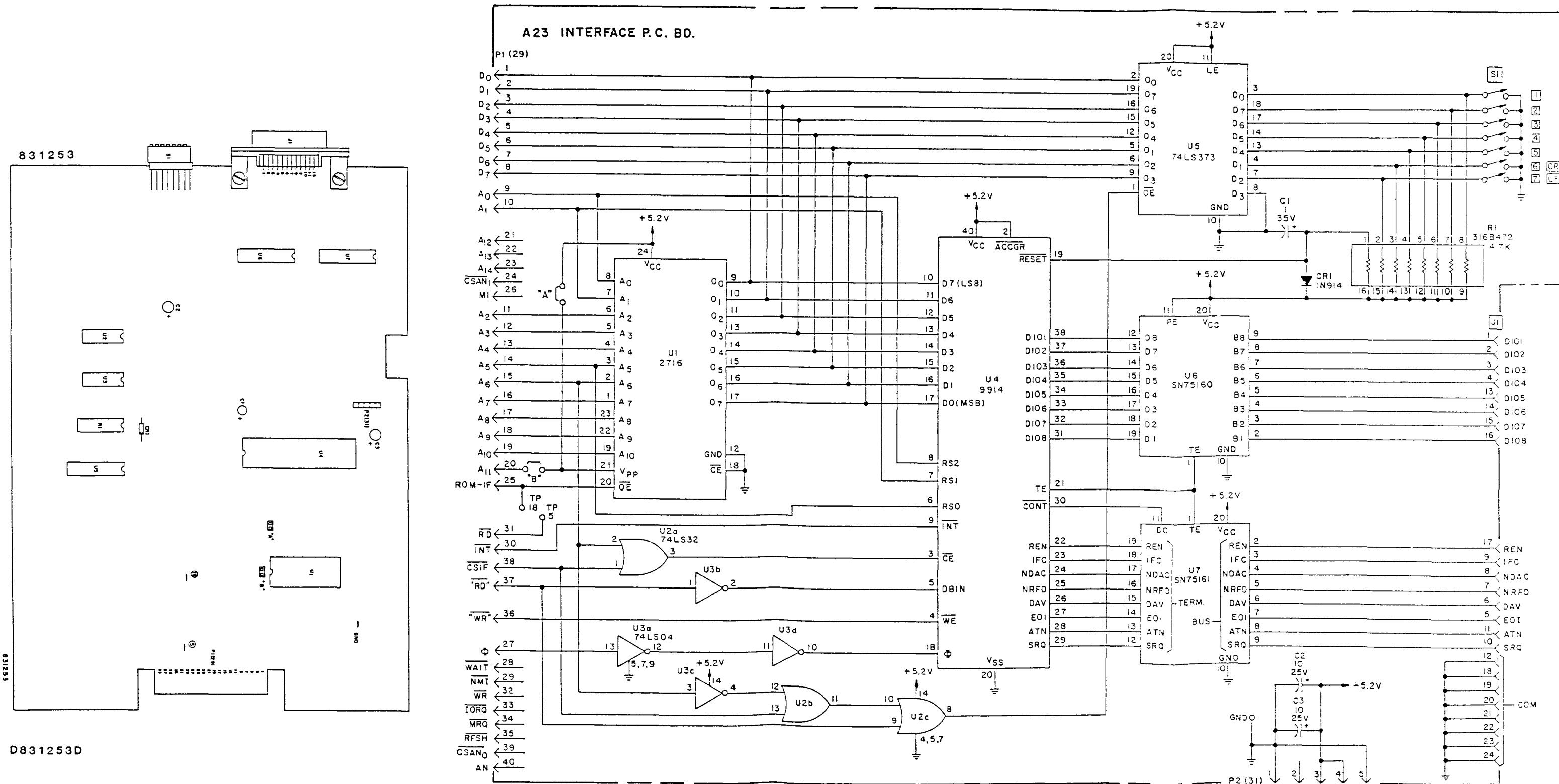

- NOTES.
1. CAPACITANCE VALUES IN μ F UNLESS OTHERWISE SPECIFIED.
 2. EXTERNAL MARKINGS.
 3. LAST NUMBERS USED:
U7
 4. TEST POINT
 5. USE JUMPER "A" FOR 16 K ROM OR JUMPER "B" FOR 32 K ROM.

P1(29)
CONNECTS TO
A20W20J28(29)
ON OPTION MAIN
FRAME SCHEMATIC
831099

P2(31)
CONNECTS TO
A1W21 J3(31)
ON MAIN SCHEMATIC
831271, SHT 1 OF 7

SCHEMATIC, INTERFACE PC. BD
D831252 C

Figure A-2 Interface Board A23, Schematic Diagram

APPENDIX B
IEEE-488 BUS INTERFACE
OPTION 4200-01B

B-1. DESCRIPTION.

B-2. The IEEE-488 (GPIB) bus interface option permits external control of the instrument and data capture by a wide variety of compatible controllers. The instrument may be operated with other GPIB-compatible devices to achieve specific test automation goals, with no specialized control interface requirements for proper electrical operation.

B-3. Although no standard GPIB interface data formats have yet been established, certain common practices are achieving de-facto standard status. These practices have been adhered to in the design of the 4200-01B option interface formats and delimiters, thereby assuring the user of format compatibility with almost all controllers.

B-4. CAPABILITY.

B-5. Certain subsets of full GPIB functions are specified in the IEEE-488 1978 Standard. The Model 4200-01B option includes the following capabilities:

- SH1 SOURCE HANDSHAKE complete capability
 - AH1 ACCEPTOR HANDSHAKE complete capability
 - T6 BASIC TALKER, SERIAL POLL, UNADDRESS IF MLA, NO TALKER ONLY capability
 - TE0 NO EXTENDED TALKER capability
 - L4 BASIC LISTENER, UNADDRESS IF MTA, NO LISTENER ONLY capability
 - LE0 NO EXTENDED LISTENER capability
 - SR1 SERVICE REQUEST capability
 - RL1 REMOTE-LOCAL capability, LOCAL LOCKOUT capability
 - PP0 NO PARALLEL POLL capability
 - DC0 NO DEVICE CLEAR capability
 - DT1 DEVICE TRIGGER capability
 - CO NO CONTROLLER capability
- MLA = My Listen Address
MTA = My Talk Address

B-6. INSTALLATION.

B-7. Option 4200-01B consists of interface board A23. Electrical interconnections are shown in Figure 7-8. To install the interface board, proceed as follows:

- a. Turn off power to the instrument.
- b. Remove the screws that secure the top cover of the instrument and slide the top cover back and off.

c. Cut the cable tie in the instrument that holds the extra power plug (the plug with two blue wires and one black wire).

d. Remove the six screws that fasten the control board and replace them with the six mounting posts supplied with the -01B package.

e. Position the interface board in the instrument so that the mounting holes in the interface board line up with the mounting posts in the instrument. Attach the interface board to the mounting posts with six 4-40 screws and lockwashers supplied with the interface board.

f. Connect the 40 pin ribbon connector to the front edge connector of the interface board.

g. Connect the power plug in the instrument to the 4-pin brown connector on the interface board.

B-8. OPERATION.

B-9. Address Assignment. Before using the instrument in the GPIB, it must be assigned a unique address. This address is set using the five right-most sections of rear-panel address switch S1 in accordance with Table B-1.

B-10. Message Terminator. Positions 6 and 7 of the rear panel switch S1 permit a choice of message terminators, as shown in Table B-2.

B-11. Command Response. In addition to Talk and Listen Address commands, the instrument responds to the following:

- a. Address Commands (Response if Listen Addressed).

Mnemonic	Name	Function
GTL	Go To Local	Enables panel control
GET	Group Execute Trigger	Trigger a measurement

- b. Listen Address Group.

Mnemonic	Name	Function
UNL	Unlisten	De-address as listener

- c. Talk Address Group.

Mnemonic	Name	Function
UNT	Untalk	De-address as talker

TABLE B-1. ADDRESS ASSIGNMENT							
*Decimal Address	Talk Code	Listen Code	Switch Setting				
			5	4	3	2	1
0	@	SP	0	0	0	0	0
1	A	!	0	0	0	0	1
2	B	"	0	0	0	1	0
3	C	#	0	0	0	1	1
4	D	\$	0	0	1	0	0
5	E	%	0	0	1	0	1
6	F	&	0	0	1	1	0
7	G	'	0	0	1	1	1
8	H	(0	1	0	0	0
9	I)	0	1	0	0	1
10	J	*	0	1	0	1	0
11	K	+	0	1	0	1	1
12	L	,	0	1	1	0	0
13	M	-	0	1	1	0	1
14	M	.	0	1	1	1	0
15	N	/	0	1	1	1	1
16	O	0	1	0	0	0	0
17	P	1	1	0	0	0	1
18	Q	2	1	0	0	1	0
19	R	3	1	0	0	1	1
20	S	4	1	0	1	0	0
21	T	5	1	0	1	0	1
22	U	6	1	0	1	1	0
23	V	7	1	0	1	1	1
24	X	8	1	1	0	0	0
25	Y	9	1	1	0	0	1
27	I	;	1	1	0	1	1
28	\	<	1	1	1	0	0
29	I	=	1	1	1	0	1
30	Λ	>	1	1	1	1	0

*Address 31 (11111) will not be recognized and should not be used.

TABLE B-2. MESSAGE-TERMINATOR SELECTION		
Switch		Message Terminator
7	6	
0	0	EOI
0	1	CR*
1	0	LF*
1	1	CR LF*

*With or without EOI

B-11. (Continued).

d. Unencoded Commands.

Mnemonic	Name	Function
IFC	Interface Clear	Initialize interface
REN	Remote Enable	Permits remote operation

B-12. Operating States. The instrument operates in two separate states, whether in local or remote control. One state is the measurement state, during which the instrument performs and displays measurements; the other state is the data entry/recall state, which is operative during number entry or after recall of stored information. When operating on the bus, it is important to remember that the instrument can send only that information which appears on the front panel display. When the instrument is in the store or recall mode, the LED display and annunciators blink on and off to indicate that the displayed value is not a measured value.

a. Measurement Mode Functions. The following functions change the measurement mode of the instrument:

Keyname	GPIB	Function
PWR MODE	P	Displays measured voltage
dB MODE	B	Displays measured dBmV

b. Command Functions. Table B-3 describes command functions.

Keyname	GPIB	Function
dB CAL FAC	D	Cal Factor Constant, in dB
RANGE AUTO	A	Sets autorange mode
RANGE HOLD	0	Sets range hold mode

TABLE B-3. COMMAND FUNCTIONS			
Command	Arm	Disarm	Description
Q	1Q	0Q	Hold command: the last reading, or the last keyboard entry, will remain on the display. The instrument will continue to read probe input, but will not update the display. The instrument cycle time will be greatly reduced because of the measurement-cycle overhead that is not executed during the hold command.
V	1V	0V	Service request command: the service request will be issued by the instrument upon completion of a measurement.
	2V		SRQ on settled reading
J	1J	0J	Raw-data command: the instrument will not average or smooth any of the measurements.
U	1U	0U	Limit command: the instrument will issue a service request if any limit is exceeded. If a limit is exceeded and a service request is issued, the U command must be rearmed to become operational again.
T			Trigger command: this command, identical with the IEEE-488 group execute trigger, initiates a measurement cycle.
INTERFACE CLEAR and DEVICE disarm all the above commands.			

B-12. (Continued).

b. Command Functions. (Continued).

Keyname	GP1B	Function
GHZ	F	Interpolates Freq/Cal Factor Table
SEL AVERAGE	0X nX	Sets auto average Sets select average (n = 1-127)

c. Service Request Status Codes. Service request status is defined by a five-bit code, as defined in Table B-4.

TABLE B-4. SERVICE REQUEST STATUS					
Bit					Meaning
4	3	2	1	0	
X	X	X	0	1	CH 1 low limit exceeding
X	X	X	1	0	Ch 1 high limit exceeding
X	0	1	X	X	Ch 2 low limit exceeding
X	1	0	X	X	Ch 2 high limit exceeding

d. Data Entry/Recall Functions. These functions enable entry or retrieval of numeric constants used by the instrument. Operation reverts to the measuring state after data storage.

Keyname	GP1B	Function
LIMITS dB L0	L	Low limit value in dB
LIMITS dB H1	H	High limit value in dB
SELECT CHNL	N	Selects channel number
dB REF LEVEL dB	R	dB reference level for dB modes
SENS	S	Selects Sensor Data Tables

e. Special Functions. Special functions include the automatic zeroing and clear functions.

Keyname	GP1B	Function
ZERO	Z	Initiate an automatic zeroing cycle
CLR	C	Clear numeric entry to zero
CAL	K	Performs 1 mW Auto Calibration

APPENDIX
OPTION 4200-01B

B-12. (Continued).

f. IEEE-488 Bus Command Extensions. The following functions are added to bus operation:

Name	GPiB	Function
ADR.ZERO	Y	Zero selected ranges (0-7)
SET RANGE	G	Set to selected range (0-7)

These commands must be preceded by an appropriate argument. The argument for Y is the span of ranges to be zeroed; for example: 26Y specifies zeroing of ranges 2 through 6. If only one range is to be zeroed, the argument must begin and end with the same code (e.g., 11Y to zero only range 1). The argument for G is the range number (0 = 10 nW to 6 = 10 nW for 4200-4 sensors) to be set. From execution of the Y command to measurement mode, the maximum time is as follows:

Command	Time	Command	Time
00Y	2.3 seconds	04Y	3.8 seconds
01Y	2.9 seconds	05Y	4.0 seconds
02Y	3.3 seconds	06Y	4.3 seconds
03Y	3.5 seconds		

The "Y" command allows no wait time for a sensor to reach a stable zero before actual offset storage occurs.

NOTE

The G command sets the 4200 to an internal range which may not correspond to the range code output in the data string in Paragraph B-21. The table below relates internal and apparent range codes:

LEVEL		INTERNAL	APPARENT
+10 dB	10 mW	-	-
		6	
+6 dB	3.98 mW	-	
0 dB	1 mW		6 -
		5	
-10 dB	100 μW		- 5 -
-11 dB	79.4 μW	-	
		4	
-20 dB	10 μW		- 4 -
-21 dB	7.94 μW	-	
		3	
-30 dB	1 μW		- 3 -
-32 dB	631 nW	-	
		2	
-40 dB	100 nW		- 2 -
-42 dB	63.1 nW	-	
		1	
-50 dB	10 nW		- 10
-52 dB	6.31 nW	-	↓
-60 dB	1 nW	0	-
		↓	

For the series 4 and 5 sensors add 10 dB to the internal and apparent levels.

For the series 6 sensor add 20 dB to the internal and apparent levels.

g. Bus Availability. When the Model 4200 is sent a string, it does not normally tie up the bus while responding to the string; other bus communications are possible during the interval. The 4200 can inform the controller when it is finished by use of the Service Request see paragraph B-12d, if this is desired.

The Model 4200 can, however, be made to lock up the bus while it is responding to a string - if such action is desired - by sending it two strings in succession (even if the second string is only a Null command).

Example: A "zero" command: wrt 716,"Z"
Followed by a "talk" command: red 716,A,B,C

B-13. TIME RESPONSE CHART.

Refer to Tables 1-3 for the Model 4200 sensor measurement through the IEEE-488 Bus.

B-14. REMOTE PROGRAMMING.

NOTE

It is assumed that the user is acquainted with GPiB principles and terminology. Refer to the controller instruction manual for the syntax needed to create specific bus commands and addressing sequences. All examples given apply to the HP 9825 calculator.

B-15. Bus Programming Syntax. The bus programming syntax mirrors the front-panel keystroke sequence closely. Each key has been assigned an alphanumeric character and sending that character is equivalent to pressing that front-panel key. The resulting operation is indistinguishable from local control. Numerical values are translated by the GPiB interface so that commonly observed formats may be used. Fixed formats and floating point formats may both be used. These representations are converted to their equivalent fixed point values and the sign information is post-fixed automatically, thereby ensuring that natural notations for numbers will be accepted by the instrument.

B-16. Suppose that it is desired to set the instrument to the PWR mode. The HP 9825 calculator could be programmed:

wrt 716, "P"

The "wrt" instructs the calculator to send data on the bus to one or more listeners. The number following is the address information; 7 is the calculator address and 16 is the instrument address. (all examples in this appendix will use 16 as the instrument address, although any valid address can be assigned to the instrument.) When the calculator interprets the first part of the line, it will assert the ATN line to signify that commands or addresses will be sent on the bus. Following that, it will send three

B-16. (Continued).

bytes or characters: Unlisten, the calculator Talk Address and the Instrument Listen Address. This information will configure both the calculator and the instrument for the data transfer. After the last command byte has been accepted, ATN will be released to the false state by the calculator. All information on the bus is interpreted as data in this mode. While in the data mode, the calculator will send the character "P" to the instrument. At the instrument, this will be interpreted as equivalent to pressing the MODE PWR key and that function will be executed. Because there is no more data to be sent, the calculator will send a delimiter (the preselected ASCII code for the termination character). The instrument recognizes the termination character as an end-of-message signal and returns to the bus idle condition.

B-17. The preceding discussion of the sending of a single programming byte serves to illustrate two important points: every data transfer is preceded by a command/address preamble and each transfer is terminated by a termination character. In the preceding example, six characters were sent on the bus; only one was a programming byte.

B-18. The measurement mode functions (P, B, A, O) and the special functions (Z, K) do not expect any numeric value. These functions all execute as received. For example: the following will program dB and autorange mode:

```
wrt 716, "BA"
  or
wrt 716, "AB"
```

Note that the sequence is unimportant, except that each function executes in the order it is received on the bus.

B-19. Suppose that the instrument is to be zeroed automatically, and then asked to send the reading in the PWR and RANGE AUTO mode. The HP 9825 calculator could be instructed as follows:

```
wrt 716, "APZ"
red 716, V, S
```

The automatic zeroing cycle time is approximately 10 to 22 seconds, depending on range. Until zeroing is completed, the instrument will be unable to respond with new data. The first line of the preceding instructions sets the operating mode and initiates the zeroing cycle. The last line reads the response from the instrument. The instrument response consists of two numeric values: the first value is the front panel reading and the second is a status value (normally zero). These two numbers will be stored in the calculator variables (storage locations) V and S. Note that each data transmission from the instru-

ment consists of two values. When the status value is non-zero, indicating an error condition, the data value will be set to zero. The program will normally test the status value to assure valid operating conditions.

B-20. Store/Recall Functions Syntax. The general syntax for store/recall functions is the same as the front panel sequence; if a numeric value immediately precedes the function, that value will be stored; otherwise, the existing stored value will be recalled to the front panel. These functions (L, H, D, F, S, N, R, J, U, V) thus operate in a dual mode. When the instrument is in the store or recall mode the display will blink to indicate that the instrument is not in the measurement mode. The instrument is returned to the measurement mode by sending any of the following: P, B, A, O, T, 1J, 0J, 1Q, 0Q, 1V, 0V, 1U or 0U.

B-21. Suppose that it is desired to store the current power level in dBm into the dBm reference so that all future readings will be referenced to the current value. Allowance must be made for the possibility that the current value is a dB relative value. To do this, the current dB value must be read, the existing dB reference must be recalled, the true dBm value must be computed and this value must be stored into dB reference. The calculator could be instructed as follows:

```
red 716, V, S
wrt 716, "R"
red 716, X, S
V + X → Y
wrt 716, Y, "R"
```

Note that R is used twice in the program, the first time to obtain the existing value for the dB reference and the second time to store the computed value. Also, note that the two read statements (red) each fetch a different value, the first value is the power value in dB and the second is the dB reference.

B-22. Output Data Format. The data output of the instrument consists of two numeric values. The first is the numeric data in the display and the second is the status information. The normal data output will have the following format:

```
abcsdddEsd, S, R (tc)
Where:
  ab = mode (power in milliwatts = PW;
         dB = DM; dBm = DR)
  c = channel (A = 1; B = 2; C = 3)
  s = sign (+ or -)
  dddd = data (four digits, each digit
            0-9)
  Esd = exponent, sign, digit
  , = data delimiter
```

TABLE B-4. RANGE CODES FOR VARIOUS SENSORS					
Range	Sensor Type				
Code	4200-4E	4200-5E	4200-6E	4200-7E	4200-8E
0	<-50 dBm	<-40 dBm	<-30 dBm	<-20 dBm	<-10 dBm
1	<-40 dBm	<-30 dBm	<-20 dBm	<-10 dBm	< 0 dBm
2	<-30 dBm	<-20 dBm	<-10 dBm	< 0 dBm	< 0 dBm
3	<-20 dBm	<-10 dBm	< 0 dBm	<+10 dBm	
4	<-10 dBm	< 0 dBm	<+10 dBm		
5	< 0 dBm	<+10 dBm	<+20 dBm		
6	<+10 dBm	<+20 dBm	<+30 dBm		

B-22. (Continued).

S = status digit:

- 0 = no error
- 1 = entry too small
- 2 = entry too large
- 3 = measurement under range
- 4 = measurement over range
- 5 = zero acquisition out of range - excessive positive offset
- 6 = zero acquisition out of range - excessive positive offset
- 7 = channel 3 over/under range

R = Range Code, coded per Table B-4

tc = termination character

B-23. Hold Indication Function Syntax. The Hold Indication function, when enabled (1Q), automatically does a measurement cycle following its receipt and then holds the indication until receipt of a T, 0Q or another 1Q command. It is intended primarily for use with the Trigger or Group Execute Trigger commands. Following its receipt, the instrument continues to measure but does not update the display. This can be useful where response time is important since display-update time is eliminated until called for with a Trigger (T) command; another 1Q command will also update the display and maintain the hold indication function; a 0Q command will update the display and negate the hold indication function.

B-24. SRQ Function Syntax. The controller can command the instrument to pull the SRQ line true after each measurement. The syntax for this command is 1S and 2S. To command the instrument not to pull the SRQ line true after each measurement the syntax is 0S. To command the instrument to pull the SRQ line true after each settled reading the syntax is 2S.

B-25. Measurement Trigger Syntax. The Trigger (T) command is an addressed command (wrt T16,"T"), used to trigger a measurement, and is generally used in conjunction with the Hold Indication function (Q). (Refer to paragraph B-23.) The instrument is also responsive to the unaddressed Group Execute Trigger (GET) command. This command is asynchronous and may result in a slightly

faster response time than the T command, which is executed only once each measurement cycle.

B-26. Limit Service Request. This command, when enabled, will result in a service request by the instrument when either dB limit (high or low) of either channel (channel 1 or channel 2) is exceeded. The limit exceeded and the channel can be determined from the service request byte as shown below:

NOTE

Bit 6, when set, is the service request.

Bit	Limit Exceeded
7 6 5 4 3 2 1 0	
X 1 X X X 0 1	Channel 1 low limit
X 1 X X X 1 0	Channel 1 high limit
X 1 X X 0 1 X X	Channel 2 low limit
X 1 X X 1 0 X X	Channel 2 high limit

B-27. Average Function Selection. To reduce the effects of noise, spurious components, etc. at lower levels, the Model 4200 employs signal averaging. The amount of averaging is a function of signal level, being highest on the lowest ranges and least on the highest ranges. When the instrument is first turned on a set of default values is assigned as follows:

fs LEVEL	RANGE	CONSTANT
10 mW	6	1
1 mW	5	1
100 μW	4	1
10 μW	3	2
1 μW	2	4
100 nW	1	20
10 nW	0	80

B-28. Increasing or decreasing these values may be accomplished by sending the instrument N (N=1 to 127) and then X. This new constant will now be in effect on all ranges and will remain in effect until changed by entering a different value, or until 0X is sent to the instrument, or the instrument is turned OFF/ON, after which the default values will be again be in effect. The value of the constant in effect can be recalled by sending the instrument X. The default values when in the AUTO mode cannot be recalled, the instrument will return a 0 to indicate the AUTO mode.

B-29. Typical Application. Suppose that it is desired to measure insertion loss or gain with an instrument equipped with option 4200-03, channel 2 measures incident power and channel 1 measures output power. The program, shown below, will request reference conditions and wait for the user to set them up. Following establishment of the reference, the program will loop on insertion loss/gain measurements. Each measurement is triggered by the user. Zeroing is prompted in the local mode at the beginning of the program. Reading errors, should they occur, will be signalled by a double beep from the calculator; normal measurements will give a single beep. There will be one print line per measurement. The reference value is not printed in this example.

Program Variable Usage:

- P: = power measurement value
- R: = range value
- S: = status value
- Z: = dummy input for prompts

Program Statements	Comments
0: cll 7	/clear interface
1: ent "zero chl, 2",Z	/prompt for zeroing
2: rem 7	/enable remote
3: wrt 716, "1NAOR2NAOR3N"	/0 dBref, auto - set ch 3
4: ent "ref measure",Z	/prompt to set up ref
5: red 716,P,S,R	/read ref value, status
6: if S>0;dsp "error",S; beep; gto 4	/test status
7: wrt 716,"1N", P,"R3N"	/set ch 1 dBref = P
8: beep;ent "measure",Z	/prompt for measurement
9: red 716,P,S,R	/read measurement, status
10: if S>0; dsp "error",S; beep;wait 100; gto 8	/test status
11: prt P,"dB"; gto 8	/print measurement
12: end	

B-30. The program in paragraph B-25 also measures reflection coefficient if channel 1 measures reflected power and channel 2 measures incident power. The reference con-

ditions are established with a short at the test port of the directional coupler.

B-31. Use of Hold Measurement (Q), Trigger (T) and Measurement Complete-SRQ (V) Commands. An example of the use of these commands using an HP85 Controller, Boonton Electronics Model 1020 Signal Generator and Model 4200 RF Microwattmeter follows:

Statement	Comment
10 ! TQVCHK	Program name
20 REMOTE 7 @ CLEAR	Enable remote; clear display
30 OUTPUT 703; "1N1SODOROQOVAB	Set Model 4200; chan- nel 1 sensor 1, 0 CAL FACTOR dB, 0 REFER- ENCE dB, no hold indication, no measurement-complete SRQ, autorange mode, dB display mode
40 OUTPUT 702; "1MH0L00N"	Set Model 1020; 1 MHz, output level of 0 dBm, output on
50 OUTPUT 703; "1Q"	Set Model 4200 to hold indication mode
60 OUTPUT 702; "0L-10"	Set Model 1020 to -10 dBm level
70 ENTER 703: A	Read model 4200; store in A
80 PRINT A	Print model 4200 indication
90 DISPLAY "PRESS CONTINUE FOR T COMMAND"	Display prompt on Model 85
100 PAUSE @ BEEP	Stop program; issue beep (press continue)
110 OUTPUT 703; "T"	Send T (trigger com- mand) to Model 4200
120 ENTER 703; A	Read model 4200 indication; store in A
130 PRINT A	Print model 4200 indication
140 OUTPUT 703; "0Q"	Set Model 4200 for indication-hold, auto range mode, dB mode
150 DISP"PRESS CONTINUE FOR 1V COMMAND"	Display prompt on Model 85
200 PAUSE @ BEEP	Stop program; issue beep
210 OUTPUT 702; "0L0"	Set Model 1020 to 10 dBm output
220 WAIT 1000	Wait 1 second for settled indication on 4200

B-31. (Continued).

Statement	Comment
230 ON INTR 7 GO TO 290	If interrupt occurs, branch to 290
240 DUTPUT 703; "1V"	Set Model 4200 to Issue a SRQ at com- pletion of measure- ment
250 WAIT 200	Wait 0.2 second
260 ENABLE INTR 7;8	Enable SRQ interrupt in Model 85
270 ON TIMER #L, 5000 GO TO 370	If no interrupt is received in 5 se- conds, branch to 370
280 GO TO 280	Wait for interrupt (or escape after 5 seconds - step 270)
290 OUTPUT 703; "0V"	At interrupt, set Model 4200 to no- measurement-complete SRQ
295 WAIT 200	Wait 0.2 seconds
300 S=SPDLL(703)	Store result of serial poll of Model 4200 in S
310 IF BIT(S,6)<>1 THEN GO TO 370	If bit 6 (SRQ bit) of Model 4200 service request byte does not equal 1, go to 370
320 PRINT "MEAS-COMP- SRQ"	If bit 6 does equal 1 (SRQ bit) print "MEAS-COMP-SRQ"
340 DISP"PRESS CONTINUE FOR 0V COMMAND"	Display prompt on Model 85
350 PAUSE @ BEEP	Stop program; issue beep
360 GO TO 260	Go to 260
370 PRINT"NO-MEAS- COMP-SRQ"	There has been no service request
380 PRINT "DONE"	Check is complete; print "DONE"

In the above example, the device addresses are:

Device	Address
HP Model 85B	7
BEC Model 1020	2
BEC Model 4200	3

The sequence of events in the above program are as follows:

HP85 Controller	Comments
RUN	The model 4200 will read the generator level of approxima- tely 0 dBm and this will be printed by the model 85B; the Model 1020 generator will change its level to -10 dBm but the Model 4200 will not change its indication since it is in the hold-indication mode; program stops at pause and waits for "CONTINUE" on Model HP85.
CONTINUE	This issues a T (trigger) com- mand to the Model 4200 which now changes to approximately -10 dBm; this is printed by the Model HP85.
CONTINUE	This initiates a sequence in which the measurement-complete- SRQ is enabled.
CONTINUE	This initiates a sequence in which the measurement-complete- SRQ has been disabled.

B-32. Model 4200 Device Dependent Statement Summary. Refer to Table B-5.

A-33. Sealed System Operation. When in sealed system operation (selected by the control board bit switch) the instrument will power up in the operate mode but, by the use of the proper GPIB commands this instrument can be placed in the DC or AC modes to allow calibration of the instrument over the bus without removal from the system rack. The GPIB commands are:

Operate Mode	"80m"
Calibrate Mode 1 (DC Cal)	"81m"
Calibrate Mode 2 (AC Cal)	"82m"

B-34. THEORY OF OPERATION.

B-35. General. Interface board A23 is a microprocessor-driven data interface which converts IEEE 488 bus compatible signals into control codes that operate the internal control bus of the instrument. It also converts instrument data into IEEE 488 compatible signals for use on the bus. All data transfers are handled by source and acceptor protocols defined by IEEE-488-1978.

B-36. Detailed Description. Refer to Figure B-1. All data manipulation and IEEE-488 bus management are controlled by CPU A23U7 in conjunction with a micro-program stored in PROM A23U8. All data transfer is handled in parallel to parallel mode by adapter A23U16. Latch A23U15 handles transfer of bit switch data that defines the instrument address and message termination characters to the instrument data bus. Bi-directional buffers A23U17 and A23U18 handle data and control signal transfers, respectively, between adapter A23U16 and the interface buses. The Ram memory A23U11 is used by the CPU for temporary storage of program variables during

TABLE B-5. MODEL 4200 DEVICE DEPENDENT* STATEMENT SUMMARY

Statement	Description	Statement	Description
T	Trigger a measurement	H	Recall high dB limit
OJ	Enable data averaging	(N)D	Enter N as CAL FACTOR in dB (N = -3.00 to +3.00)
1J	Disable data averaging	D	Recall CAL FACTOR in dB
J	Recall state of J to display (0 or 1)	(N)F	Enter N as frequency as CAL FACTOR GHz determination (N = 0.1 to 999.9)
OU	Disable dB-limit-exceeded service request	F	Recall frequency for CAL FACTOR GHz determination
1U	Enable dB-limit-exceeded service request	(N)S	Enter N as sensor number (N = 1 through 8)
U	Recall state of U to display (0 or 1)	S	Recall sensor number
OV	Disable service request at measurement completion	(M)N	Enter M as channel number (M = 1 through 3)
1V	Enable service request at measurement completion	N	Recall channel number
2V	Enable Service Request on settled reading	(N)R	Enter N as dB reference level (N = -99.99 to +99.99)
V	Recall state of V to display (0 or 1)	R	Recall dB reference level
0Q	Disable display indication hold	Z	Initiate automatic zeroing cycle
1Q	Enable display indication hold	K	Perform 1 mW automatic calibration
P	Display measurement in power	C	Clear numeric entry to 0
B	Display measurement in dB	(NM)Y	Zero ranges N through M (N = 0 through 6; M = 0 through 6; both must be used)
A	Enable autorange mode	(N)G	Set instrument to range N (N = 0 through 6)
O	Enable hold-range mode	OX	Enables auto average
(N)L	Enter N as high dB limit (N = -99.99 to +99.99)	(N)X	Enter N as number of samples to average
L	Recall low dB limit		
(N)H	Enter N as high dB limit (N = -99.99 to +99.99)		

* All other commands are controller dependent; see controller instruction manual.

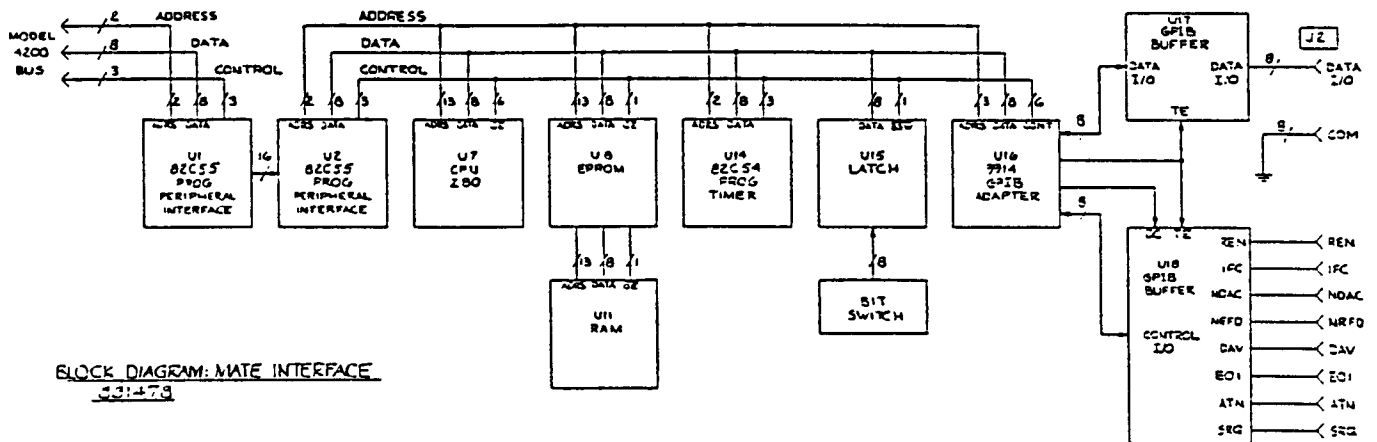

Figure B-1. IEEE-488 Bus Interface Option 4200-01B Block Diagram

B-36. (Continued).

program execution. A23U14 the program timer is only used by the -06 MATE option for timing required under CIIL operation. A23U1 and A23U2 the programmable peripheral interfaces form a "mailbox" for data transfer between the Instrument and Interface address, control, and data buses.

B-37. When the Instrument is turned on, or when the supply voltage goes low, the supply voltage supervisor A23U5 keeps the reset line active until the power supply voltage has reached its nominal voltage value, thereby resetting the CPU A23U7 and clearing the adapter A23U16.

B-38. Instrument address and message termination character data that is preset by bit switch A23S1 is supplied to latch A23U15. To read the switch data, address bits AB4, AB5, and control signal \overline{TORD} are activated producing signal \overline{BSW} and enabling the latch output. The switch data is then transferred through the latch to the Interface data bus.

B-39. To read Incoming Interface control signals, the CPU activates signals \overline{TORD} and sets address bit AB4 low. The Interface control signal port of adapter A23U16 is selected through address bits AB0, AB1, and AB2. Adapter A23U16 is enabled through decoder A23U12. Because signal \overline{TORD} is active, signal TE supplied by the adapter to buffer A23U18 is inactive and this buffer is set up for data transfer from the Interface control signal bus to the control signal port of adapter A23U16. Incoming Interface control signals are transferred through buffer A23U18 and adapter A23U16 to the Instrument data bus. Clocking of adapter

operations is controlled by the clock signal ZCLK which is generated by A23U4b and divided by A23U6. ZCLK also supplies the required clock to the CPU A23U7. Interface control signal transfer in the opposite direction is achieved by reversing the states of signals \overline{TORD} and \overline{TOWR} . An active \overline{TOWR} causes signal TE to buffer A23U18 to become active, thereby reversing the direction of data flow through the buffer. Interface control signals from the Interface data bus are then written onto the Interface control bus through adapter A23U16 and buffer A23U18.

B-40. To handle data transfers between the Interface data bus and the Interface connector A23J2, adapter A23U16 is similarly enabled through decoder A23U12 by low address bit AB4. Address bits A0, A1, and A2 are set to select the data port of adapter A23U16, and signals \overline{TOWR} and \overline{TORD} specify the write and read functions. If data is to be written to the Interface connector A23J2 signal \overline{TOWR} is activated, thereby activating signal TE to buffer to buffer A23U17. Data on the Interface data bus is then transferred through adapter A23U16 and buffer A23U17 to connector A23J2. For data transfers from connector A23J2 to the Interface data bus, signal \overline{TORD} is inactive and signal \overline{TORD} is active. Signal TE to buffer A23U17 is deactivated by adapter A23U16 to reverse the direction of data transfer through the buffer.

B-41. MAINTENANCE.

B-42. General. The Interface board does not operate alone, but rather in conjunction with the Model 4200. If Interface operation becomes abnormal it should first be determined if the 4200 operates normally without the Interface. If it does, proceed according to the following paragraphs.

B-43. Physical Inspection. Check the interface board visually for loose or broken connectors, unseated IC's, foreign material, etc.

B-44. Voltage Checks. With the board installed in the 4200, and all connectors in place, check the supply - and IC - voltages according to the values shown on the schematic diagrams, Figures B-2, B-3, and B-4.

B-45. Active-Device Substitution. All the active devices are socketed, making replacement simple. Replace each device, one at a time, and check for restoration of proper performance by the instrument.

B-46. Troubleshooting. An oscilloscope, while not the most useful tool for troubleshooting bus-oriented microprocessor systems, still may be used to determine activity or lack of activity on the address, data and control lines.

B-47. REPLACEABLE PARTS.

B-48. Table 6-2 lists all the replaceable parts and includes; Reference Symbol, Description, Mfr., Mfr's Part No., and the BEC Part No.

B-49. SCHEMATICS.

B-50. Refer to Figures B2, B3, and B4 for the schematics for the 4200-01B Option.

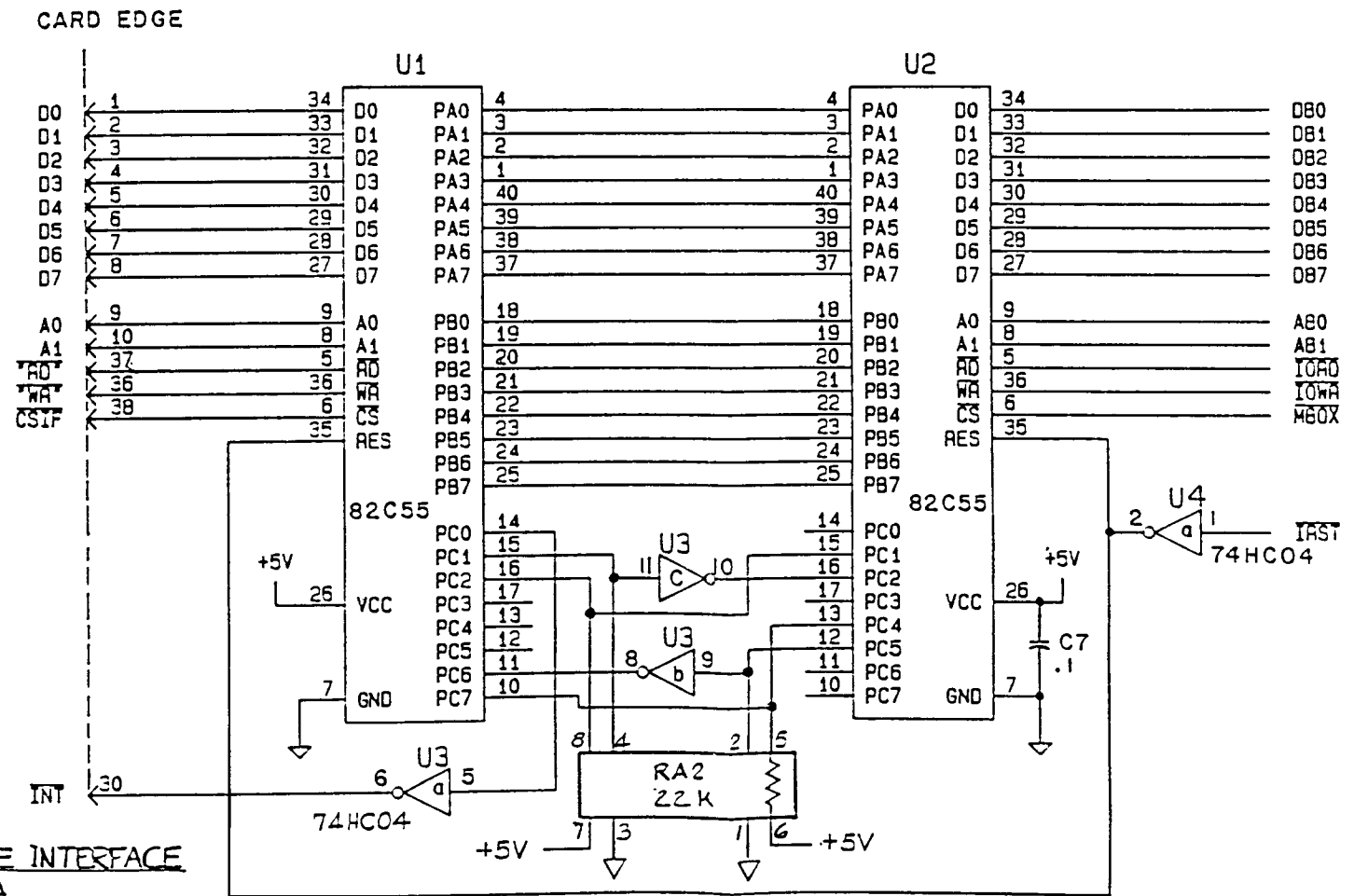
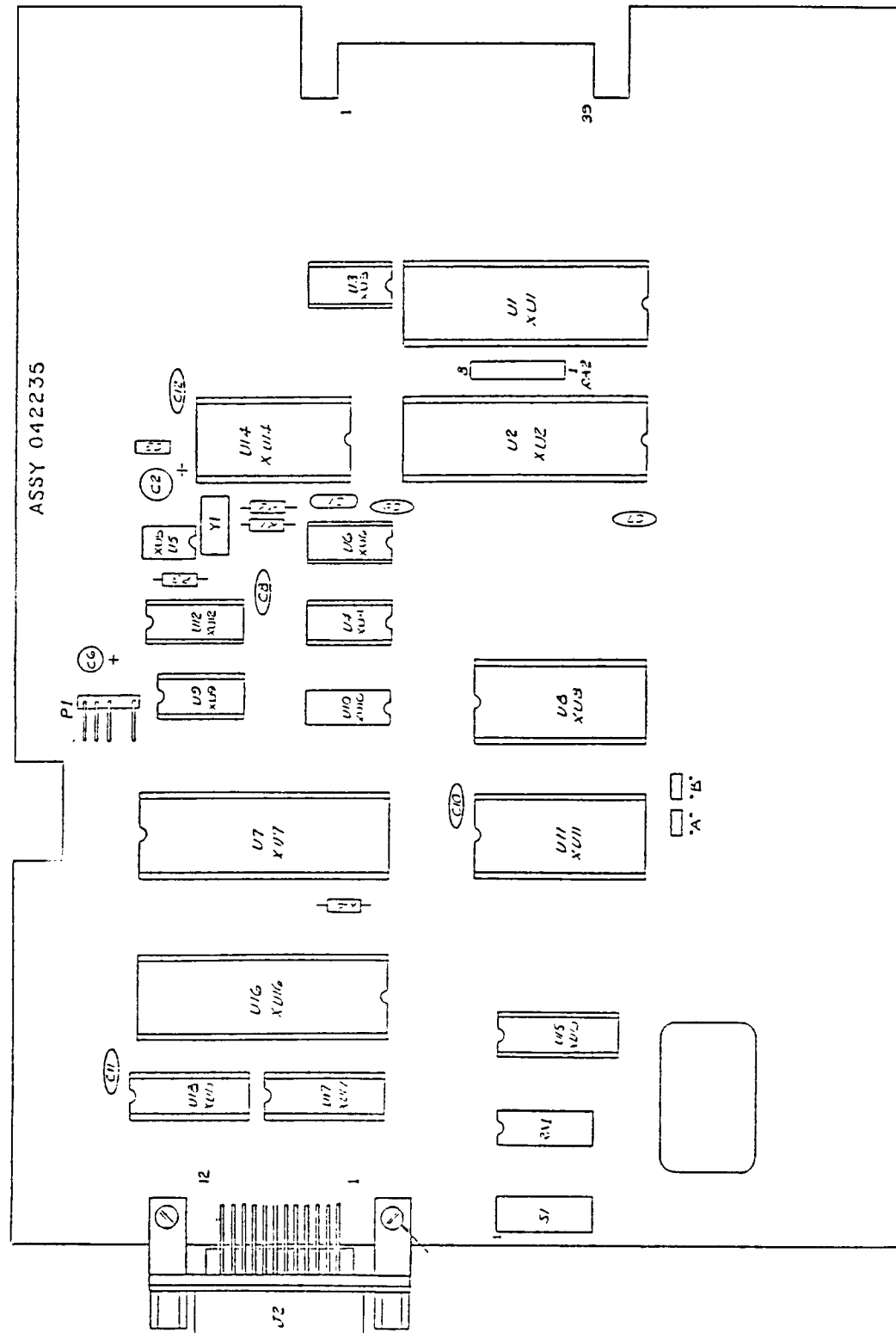

SCHEMATIC MATE INTERFACE
83145901A

NOTES:

1. CAPACITOR VALUES IN UF UNLESS OTHERWISE SPECIFIED.
2. RESISTANCE VALUES IN OHMS UNLESS OTHERWISE SPEC.
3. USE JUMPER "A" WHEN U11 IS A 2K ROM.
USE JUMPER "B" WHEN U11 IS A 8K ROM.
4. LAST NUMBER USED: R8, C12, U18, J4
NUMBERS NOT USED: R5, R6, R7; C4, C5; U13.

Figure B-2. A23 Interface PC Board Schematic and Component Location Diagram
Sheet 1 of 3

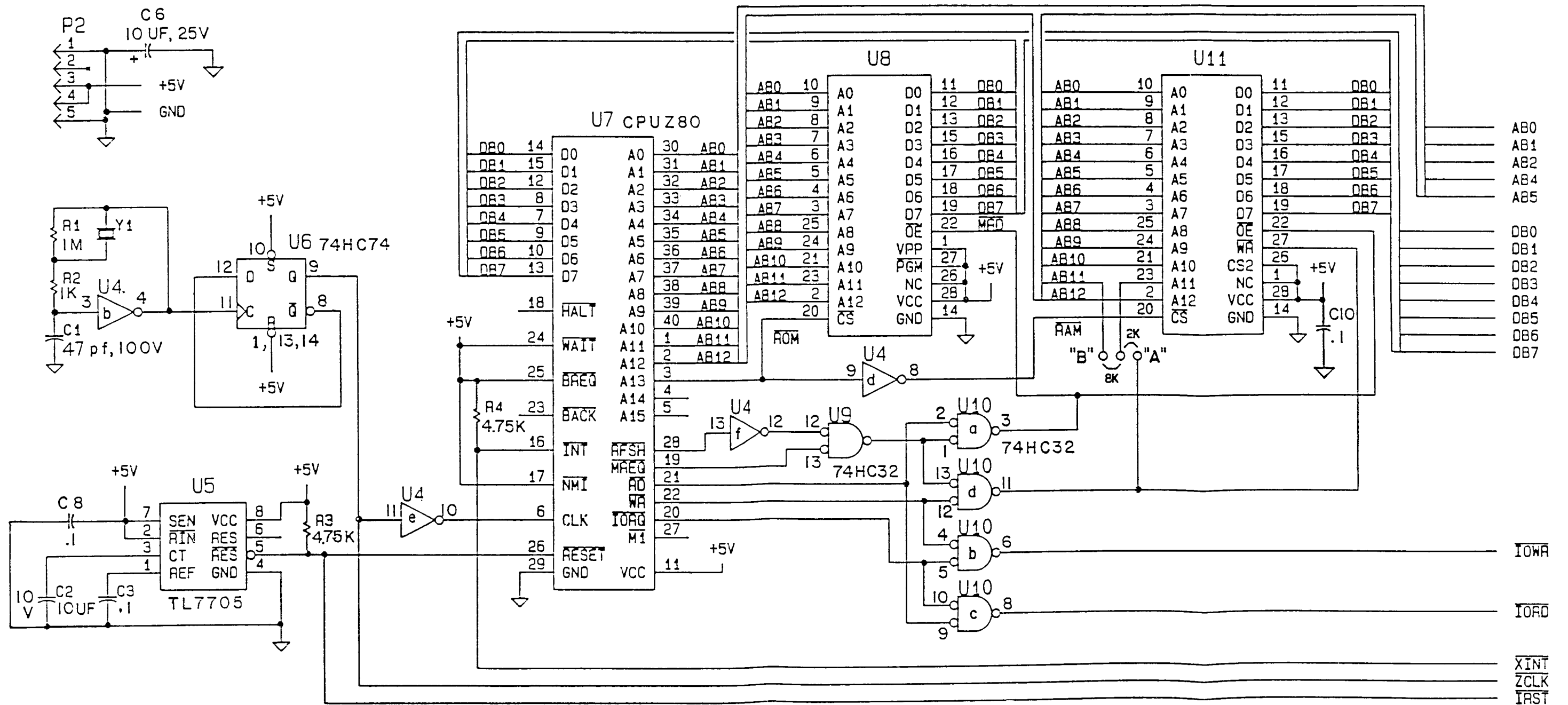

SCHEMATIC. MATE INTERFACE
83145902A

Figure B-3. A23 Interface PC Board Schematic
Sheet 2 of 3

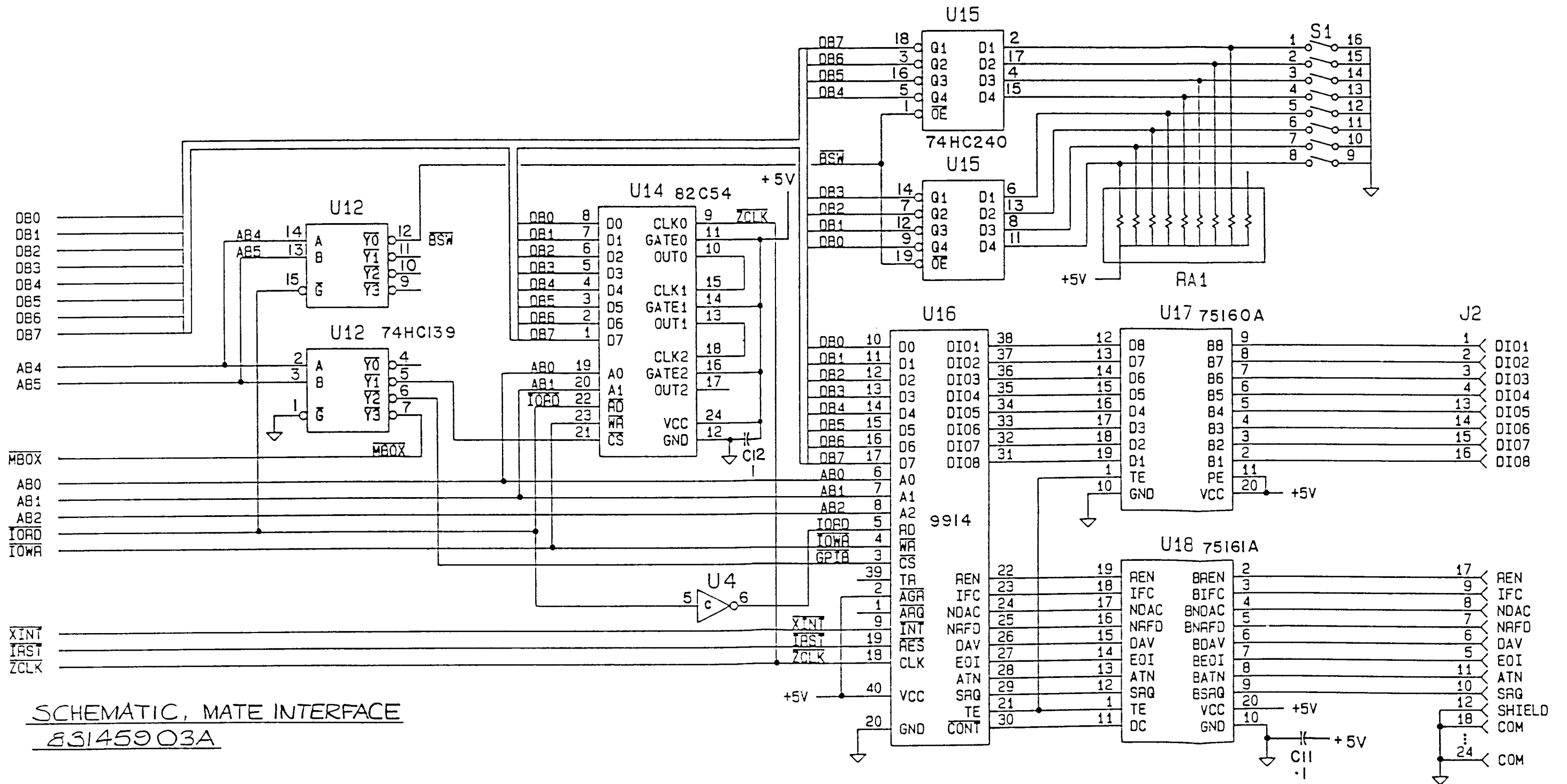

Figure B-4. A23 Interface PC Board Schematic
Sheet 3 of 3

APPENDIX C
INPUT CHANNEL 2
OPTION 4200-03

C-1. DESCRIPTION.

C-2. Option 4200-03 provides an additional measurement channel (channel 2) that is completely similar to channel 1 except for mounting and input connector location. The input channel 2 connector for this channel is mounted on the rear panel of the instrument. With this option installed, measurements may be made on each channel individually, or both channels can be monitored automatically and the difference in dB displayed. This option consists of an input module, complete with chopper, that connects to the 40 line bus and has its own power connector. Connections are shown in Figure 7-8.

C-3. INSTALLATION AND REMOVAL.

C-4. To install and remove the Input Channel 2 Option, proceed as follows:

- a. Turn the instrument bottom up. Remove the screws that secure the bottom cover and slide the bottom cover back and off.
- b. Install the rear input connector at the left side of the rear panel.
- c. Dress the cable from the rear input connector down the left side frame of the instrument (as viewed from the bottom of the instrument) and across the front sub panel. The cable will run below the module being installed.
- d. Secure the cable grounding lug under the uppermost, right-most binder-head screw (6-32) in the front sub-panel.
- e. Install the channel 2 input module and secure it to the side frames of the instrument with the four screws supplied.
- f. Remove the four corner screws that secure the channel 2 input module cover and remove the cover.
- g. Plug the chopper into the channel 2 input module, seating the chopper firmly.
- h. Connect the 40 pin ribbon cable connector to the front edge connector of the channel 2 input module.
- i. Connect the power cable supplied to the power supply (position 8) with the black lead on the right side (as viewed from the bottom of the instrument), and to the input module (rear) with the black lead on the right.

NOTE

Avoid reversal of the two ends of this cable; there is lead transposition.

- j. Install the channel 2 input module cover that was removed in step g.
- k. Install the side covers and the bottom cover removed in steps a and b.

l. To remove the channel 2 input module, reverse the above procedure.

C-5. OPERATION.

C-6. When option 4200-03 is installed, each of the two input channels may be operated with any of up to eight sensors. Channel and sensor data entered through the keyboard are selected as a set; that is, once a channel selection followed by a sensor selection has been made, subsequent selection of that channel causes selection of that sensor automatically. Subsequent selection of that sensor through the keyboard, however, does not cause automatic selection of that channel. Sensor assignment to a particular channel can be changed at any time by selecting the channel through the keyboard, then making another sensor selection through the keyboard.

C-7. Channel 1 and channel 2 operating procedures are basically the same as those described in Section 11 of this manual. A channel 3 mode of operation may also be selected. In channel 3 mode, the input levels to channels 1 and 2 are both monitored, and the difference between the two inputs, in dB only, is displayed on the instrument LED display. The following parameters selected for channels 1 and 2 prior to selection of the channel 3 mode remain operative for channel 3 mode operation:

- a. Autoranging or range hold (for each channel).
- b. Limits (for each channel).
- c. dB reference levels (for each channel).
- d. Sensor selection.
- e. Zeroing.
- f. Calibration.

C-8. When channel 3 mode has been selected, the following keys are inactive:

- a. ZERO.
- b. CAL.
- c. MODE PWR.
- d. MODE dB (automatically in this mode).
- e. dB LIMITS LO and dB LIMITS HI.
- f. dB REF LEVEL dB.
- g. CAL FACTOR dB.

In channel 3 mode, the instrument does respond to a CAL FACTOR GHz key command, applying the stored calibration factor for each selected sensor for that frequency. (Refer to Tables 5-19, 5-20, 5-21 and 5-22.) For a description of recorder output in the Channel-3 mode, see page 3-13, paragraph 3-33c.

APPENDIX C
OPTION 4200-03

C-9. MAINTENANCE.

C-10. The procedures used to isolate malfunctions to the channel 2 input module are similar to those described for the channel 1 input module in Section V. (Refer to paragraph 5-22.) Signature analysis techniques are used to isolate defective parts on the channel 2 input module. For convenience, the signature analysis information for the channel 2 input module is included in Section V. (Refer to Tables 5-19, 5-20, 5-21 and 5-22.)

C-44. REPLACEABLE PARTS.

C-45. Table 6-2 lists all the replaceable parts and includes; Reference Symbol, Description, Mfr., Mfr's Part No., and the BEC Part No., for the channel 2 input module which is identical to the channel 1 input module P/N 04223001B.

C-46. SCHEMATICS.

C-47. Refer to Figures 7-6, Sh 1 and 2 Input Module Board A6 Schematic Diagrams for the channel 1 and channel 2 schematics and parts location diagram.

APPENDIX D
REAR INPUT
OPTION 4200-04

D-1. DESCRIPTION.

D-2. Rear Input option 4200-04 provides a second power sensor connector on the rear panel for those applications where sensor connection to the rear of the instrument may be more convenient. The second power sensor connector is connected in parallel with the front panel SENSOR connector. Refer to Figure 7-8.

D-3. OPERATION.

D-4. To operate an instrument equipped with the 4200-04 option, connect the power sensor cable to either the front panel or rear panel input channel 1 connector, as desired, and affix the shield supplied with the option to the unused connector. Then, proceed with operation as described in Section II of the 4200 manual.

NOTE

Do not attempt to use both input connectors at the same time; use only one and make sure that the shield is affixed to the other.

APPENDIX E
INTERNAL TMA (MATE)
OPTION 4200-06

E-1. DESCRIPTION.

E-2. The 4200-06 option provides IEEE-488 programming syntax which conforms to MATE System Control Interface Standard. The protocol is the CIL subset of the ATLAS control language.

E-3. The 4200-06 option consists of the items listed in Table E-1.

E-4. MATE CONFIGURATION.

E-5. The 4200-06 option allows two main modes of operation, selected by Bit Switch 8 of the Interface Board Bit Switch as listed in Table E-2.

E-6. The MATE/native mode selection is made during power-on initialization. To change mode, the instrument must be turned off before Bit Switch 8 is changed. When power is re-applied, the new mode will be in effect.

E-7. When the 4200-06 powers up in the MATE compatible mode, the active channel is set to the following conditions:

- a. dBm Mode
- b. Autorange Mode
- c. High dB Limit = 99.99
- d. Low dB Limit = -99.99
- e. Raw data flag cleared

E-8. While the 4200-06 is in IEEE-488 LOCAL mode, all panel functions are available to the operator. This includes all of the con-

ditions preset during power-up. When the system controller places the 4200-06 into the REMOTE mode, the above initializations will be restored. All panel controls are inoperative while the 4200-06 is in REMOTE mode.

E-9. The 4200-06 option supports two-channel operation if the second-channel hardware is installed. Attempts to access a non-existent channel will generate an illegal channel error message. The first channel is addressed as :CH0 or :CH00, and the second as :CH1 or :CH01.

E-10. OPERATION.

E-11. Users of this option must be familiar with the MATE standard. Only the specific CIL commands and protocols applicable to the 4200 are discussed in this supplement.

E-12. A MATE measurement consists of the following operations:

- a. SETUP: FNC command
- b. CLOSURE: CLS command
- c. INITIATION: INX command
- d. RESULT FETCH: FTH command
- e. DISCONNECT: OPN command
- f. RESET: RST command

E-13. Each of the first three steps (SETUP, CLOSURE and INITIATION) must be done in that sequence. An error message will be generated if the requisite prior steps have not been successfully performed.

TABLE E-1. 4200-06 Option Items.

Item	P/N	Location	Replaces	P/N
A23	04223500A	A23 Interface Bd.	A23	042317010
IC6	53442800A	A5 Control Bd.	A5IC6	534317000
IC7	53442900A	A5 Control Bd.	A5IC7	534318000

TABLE E-2. Bit Switch S1 Settings.

	Bit Switch No.							Operating Mode	
	8	7	6	5	4	3	2		1
0	-	-	-	-	-	-	-	-	Native (non-MATE) IEEE-488 control
C	X	X	-	-	-	-	-	-	MATE compatible IEEE-488 control

C = closed (Logic 0), 0 = open (Logic 1), X = don't care, - = as required.

APPENDIX E
OPTION 4200-06

E-14. SETUP. The SETUP command syntax is as follows:

FNC ACS POWR :CHn (optional limits) <cr><lf>

where :CHn = :CH0, :CH00, :CH1, or :CH01
<cr> = ascii return, <lf> = ascii line-feed

E-15. The optional limits set minimum and maximum values for power, and the operating frequency. These limits will default to values appropriate for the particular sensor in use, with the minimum power set to -99.99 dBm.

E-16. With the 4200-4E sensor, for example, the default limits would be:

Maximum power = +10.00 dBm
Minimum power = -99.99 dBm
Signal frequency = 200 kilohertz

E-17. Each limit may be optionally set within the FNC command string. Any limit not set will retain its default value:

Command	Comment
SRX POWR value	Max power: range = PMIN to sensor max
SRN POWR value	Min power: range = -99.99 dBm to PMAX
SET POWR AUTO	Use sensor determined defaults
SET FREQ value	Frequency: range = sensor min to sensor max

Note: value = ascii numeric string, fixed or floating point

E-18. If no error is detected while parsing the FNC string, the active channel will be set as determined by the :CHn modifier, and the limit values will be effective until a new SETUP or a RESET occurs.

E-19. The following messages may be generated while parsing the SETUP command:

- a. No error: <sp><cr><lf>
- b. Unrecognized operand: F07PwM0n (MOD): ILLEGAL NOUN/NOUN MOD. zzz<cr><lf>
- c. Operand out of sequence: F07PwM0n (MOD): ILLEGAL zzz PROGRAMMED POWERMETER <cr><lf>
- d. Missing operand(s) at end of command: F07PwM0n (MOD): ILLEGAL SYNTAX PROGRAMMED POWERMETER <cr><lf>
- e. Improper channel command: F07PwM0n (DEV): ILLEGAL CHANNEL PROGRAMMED POWERMETER <cr><lf>
- f. Maximum voltage out of allowable range: F07PwM0n (DEV): ILLEGAL MAXIMUM PROGRAMMED POWERMETER <cr><lf>
- g. Minimum voltage out of allowable range: F07PwM0n (MOD): ILLEGAL MINIMUM PROGRAMMED POWERMETER <cr><lf>

h. Frequency limit out of allowable range: F07PwM0n (DEV): ILLEGAL FREQUENCY PROGRAMMED POWERMETER <cr><lf>

Notes: <sp> = ascii space
n = 0 or 1
zzz = unrecognized or illegal operand, truncated to 20 char.

E-20. Errors b, c and d are general syntax errors, and may occur during any improperly constructed command string. In the sections that follow they will be termed "syntax errors", and will not be separately shown.

E-21. A special form of setup is used to command the auto-zeroing cycle:

FNC ACS ZERP :CHn <cr><lf>

E-22. The measurement cycle which follows becomes a dummy measurement during which auto-zeroing occurs. The CLS, INX and FTH operations described below must still be performed to accomplish autozeroing.

E-23. CLOSURE. After successful SETUP, the 4200 must be CLOSED. The command syntax is:

CLS :CHn<cr><lf>

E-24. The channel number must agree with the current active channel, as set by the FNC command string. If it does not, an illegal channel message will be generated.

E-25. In addition to syntax errors, the following messages may be generated:

- a. No error: <sp><cr><lf>
- b. Improper channel command: F07PwM0n (DEV): ILLEGAL CHANNEL PROGRAMMED POWERMETER <cr><lf>
- c. Instrument not SETUP: F07PwM0n (MOD): POWERMETER NOT SETUP <cr><lf>

E-26. INITIATION. Each measurement must be INITIATED before any result can be obtained. The command syntax is:

INX POWR <cr><lf>

E-27. If no error condition is encountered while parsing the above command, the 4200 computes the time required to complete the measurement and places the time in the output buffer. The output buffer is enabled, and the controller is expected to read this value and use it to determine its I/O timeout limit.

E-28. A measurement is then initiated. During this time, the 4200 is able to accept the follow-on FTH command string, but will not return data until the measurement is complete.

E-29. A special case for INX is created when the ZERP noun-modifier was used in the FNC command. The time required to complete the autozero cycle will be returned. The result phase (FTH) after autozero is always zero, unless an error is being reported.

E-30. In addition to syntax errors, the following messages may be generated:

- a. No error: <sp>dddd<cr><lf>
- b. Instrument not SETUP: F07PwM0n (MOD):
POWERMETER NOT SETUP <cr><lf>
- c. Instrument not CLOSED: F07PwM0n (MOD):
POWERMETER NOT CONNECTED <cr><lf>

Note: d = ascii numeric digit (0 - 9)

E-31. RESULT FETCH. The measurement value is requested by the command:

FTH POWR <cr><lf>

E-32. The instrument will determine if a settled reading was possible within the settling time limit reported to the controller during the INX command. The measurement value is tested against the maximum and minimum limits established during the SETUP command. If no errors occur, the reading is loaded into the output buffer; otherwise, an error message is loaded.

E-33. Execution of the FTH command also returns the 4200 to CLOSED and not-INITIATED status. Any number of successive INX - FTH measurement cycles may be performed while still CLOSED.

E-34. In addition to syntax errors, the following messages may be generated:

- a. No error: <sp>0.ddddEsd<cr><lf>
- b. Instrument not SETUP; F07PwM0n (MOD):
POWERMETER NOT SETUP <cr><lf>
- c. Instrument not CLOSED: F07PwM0n (MOD):
POWERMETER NOT CONNECTED <cr><lf>
- d. Measurement not INITIATED: F07PwM0n
(MOD): MEASUREMENT NOT INITIATED <cr><lf>
- e. Measurement did not settle: F05PwM0n
(DEV): MEASUREMENT TIMEOUT <cr><lf>
- f. Measurement exceeded maximum limit: F00PwM0n (DEV): MEASURED POWER GREATER THAN
MAXIMUM <cr><lf>
- g. Measurement less than minimum limit: F01PwM0n (DEV): MEASURED POWER LESS THAN
MINIMUM <cr><lf>

Notes: s = exponent sign, +/-

E-35. DISCONNECT. The 4200 may be logically disconnected from the test system by the command:

OPN :CHn<cr><lf>

E-36. The channel identification must agree with the currently active channel; otherwise an illegal channel error will be generated. The channel must have been SETUP prior to issuing this command.

E-37. After execution of the OPN command, it is necessary to send the CLS command prior to INX and FTH commands.

E-38. In addition to syntax errors, the following messages may be generated:

- a. No error: <sp><cr><lf>
- b. Improper channel command: F07PwM0n
(DEV): ILLEGAL CHANNEL PROGRAMMED
POWERMETER <cr><lf>
- c. Instrument not SETUP: F07PwM0n (MOD):
POWERMETER NOT SETUP <cr><lf>

E-39. RESET. The RESET command addresses a specific channel, clears any pending error messages and sets the 4200 to not-SETUP status. The syntax is:

RST ACS POWR :CHn<cr><lf>

E-40. An illegal channel error message is generated if the channel addressed does not exist.

E-41. The IEEE-488 bus command DCL (Device Clear) will perform a RESET on the currently active channel.

E-42. In addition to syntax errors, the following messages may be generated:

- a. No error: <sp><cr><lf>
- b. Improper channel command: F07PwM0n
(DEV): ILLEGAL CHANNEL PROGRAMMED
POWERMETER <cr><lf>

E-43. SELF TEST. Two self-test commands are recognized by the 4200, but the same internal test is done for both. The test is a checksum verification of the 4200 program memory. The command syntax is:

CNF<cr><lf> or IST<cr><lf>

E-44. Each of these commands also does an implied RESET, returning the 4200 to not-SETUP status, and clearing any pending errors prior to self-test.

E-45. In addition to syntax errors, the following messages may be generated:

- a. No error: <sp><cr><lf>
- b. Checksum error, CNF command: F07PwM0n
(DEV): CONFIDENCE TEST FAILURE <cr><lf>
- c. Checksum error, IST command: F07PwM0n
(DEV): BIT TEST FAILURE RAM/ROM <cr><lf>

E-46. STATUS COMMAND. Messages in the output buffer must be enabled prior to being sent to the controller. Except after an INX or FTH command, which implicitly enable the output buffer, the STA command must be sent to access the current message. When the STA command is received by the 4200, the no-error message is loaded unless an error message is already present, and the buffer is enabled. A subsequent talk command on the IEEE-488 bus will cause the message to be sent to the controller.

APPENDIX E
OPTION 4200-06

E-47. Any error message in the output buffer prevents further loading of the buffer until the message is sent over the bus, or a RESET occurs.

E-48. The syntax for the STATUS command is:

STA<cr><lf>

E-49. If no error message exists in the output buffer, the following message is generated:

a. No errors: <sp><cr><lf>

E-50. MAINTENANCE.

E-51. To perform any of the maintenance procedures outlined in Section IV of the 4200 Manual, set Interface Board Bit Switch 8 for native mode operation. This will allow IEEE-488 access to Instrument calibration functions. Restore the MATE configuration after maintenance procedures are complete.

E-52. REPLACEABLE PARTS.

E-53. Table 6-2 lists all the replaceable parts and includes; Reference Symbol, Description, Mfr., Mfr's Part No., and the BEC Part No.

E-54. SCHEMATICS.

E-55. Refer to Figures B2, B3, and B4 for the schematics for the 4200-01B Option.

APPENDIX F
REAR INPUT
OPTION 4200-S/17

F-1. DESCRIPTION.

NOTE

The -S/17 option can only be used in conjunction with the -03 option.

F-2. Rear input option 4200-S/17 provides channel inputs on both the front and rear panels so that the sensor connections to the second power sensor connector on the rear panel for those applications where sensor connection to the rear of the instrument may be more convenient. The second power sensor connector is connected in parallel with the front panel SENSOR connector. Refer to Figure 7-8.

F-3. OPERATION.

F-4. To operate an instrument equipped with the 4200-S/17 option, connect the power sensor cable to either the front panel or rear panel input channel connector, as desired, and affix the shield supplied with the option to the unused connector. Then, proceed with operation as described in Section 11 of the 4200 manual.

NOTE

Do not attempt to use both input connectors at the same time; use only one and make sure that the shield is affixed to the other.

MODEL 4200 INSTRUCTION MANUAL SUPPLEMENT
FOR THE MODEL 4200-S/21
June 17, 1987

Instruction-manual supplements are issued as required to correct errors in a manual, and to adapt the manual to changes made after its printing.

Make the following additions to the Manual.

1. The following items have been added to the Model 4200 for the -S/21:
 - a. Batteries BT2 and BT3. (2) 1.5 V alkaline batteries replace BT1. Refer to Figure 1.
 - b. An Elapsed Time Indicator MI and associated 357 k ohm resistor. Refer to Figure 1.
 - c. A 1 k ohm resistor is connected to the recorder output and rear panel ground to provide a 1 V full scale output.
2. Extending the RMS measuring range of sensors note.
 - a. The true RMS detection area of the 4200-4E-S/21 sensor is from -60 dBm to -20 dBm and -40 dBm to 0 dBm for the 4200-6E sensor. These ranges may be extended by adding attenuation to the sensor input. For each dB of attenuation added the RMS range will shift upwards by 1 dB. The low end sensitivity will also rise by 1 dB. By adding the 20 dB attenuator 951054/2 supplied in the 4200-S/21 Test Set, the RMS ranges will be changed to -40 to 0 dBm for the 4200-4E-S/21 and -20 to +20 dBm for the 4200-6E.
 - b. To correct the display for the attenuator in use enter the attenuation value for the frequency of interest from the calibration data sheet supplied with the attenuator and then press the REF LEVEL dB key.
 - c. For example: If the attenuation value at 16 GHz is -19.85 dB as read from the Calibration Data Sheet, press 1, 9, ., 8, 5, CHS, and then press the REF LEVEL dB key.
 - d. This technique will work with any attenuator for which absolute attenuation values across the frequency range are known. Attenuators are not calibrated with specific sensors and are not required to be matched as pairs.
3. On Page 1-8, Table 1-2, change the 4200-4E-S/21 MAX. SWR specifications to <1.4 from 4 GHz to 18 GHz.
4. On Page 2-2, paragraph 2-7b, replace the following text and table:
 - b. Recorder Output. Recorder connector J20 (type BNC) on the rear panel provides an analog DC voltage for application to a remote recorder. The output resistance is 1000 ohms. The analog DC voltage is proportional to the following:
 - (1). In the power mode, it is proportional to displayed power, with 1 volt for full scale each range, either channel.
 - (2). In the dB mode, it is proportional to displayed dBm with the relationship shown below:

Recorder Output

dBm	Series 4/7/K/KA/Q (volts)	Series 5/8 (volts)	Series 6 (volts)
+30	-	-	.9
+20	-	.9	.8
+10	.9	.8	.7
0	.8	.7	.6
-10	.7	.6	.5
-20	.6	.5	.4
-30	.5	.4	.3
-40	.4	.3	.2
-50	.3	.2	-
-60	.2	-	-

5. On Page 3-11, paragraph 3-33, replace the following text:

b. In the dB mode, the DC output level is proportional to dBm according to the formula (Series 4/7/K/KA/Q Sensors)

$$V_{OUT} = (.8 + \frac{dBm}{100}) \text{ volts}$$

Example: The voltage output at -20 dBm would be:

$$(.8 + \frac{-20}{100}) \text{ volts} = .6 \text{ volts}$$

This output is a function of dBm only, but is effected by CAL FACTOR entries.

c. In the Channel-3 mode of operation (Option -03), the recorder output is proportional to the difference in dB of channel 1 minus Channel 2. This output is effected by both the calibration factors and the dB reference levels entered in each channel. The equation is:

$$\begin{aligned} & \text{RECORDER OUT (VOLTS)} \\ & = \frac{(\text{dBch.1} + \text{dB CAL FACT CH1} - \text{dB REF.ch.1}) - (\text{dBch.2} + \text{dB CAL FACT CH2} + \text{dB REF.ch.2})}{100} \end{aligned}$$

Or, equivalent:

$$\text{RECORDER OUT (VOLT)} = \frac{\text{dB display}}{100} + .8$$

Valid recorder outputs will be obtained for display indications of -80 dB (0 volts) to +30 dB (1.1 volts).

6. On Page 5-22, paragraph 5-34, replace the following text:

e. With 1.000 mW indicated on the LED display, check the indication on the digital multimeter; it should be .98 to 1.00 volts. If the indication is correct, proceed directly to step h; if the indication is incorrect, proceed to step f.

f. If the digital multimeter indication in preceding step e was incorrect, set the control board bit switch to CALIBRATE MODE 1, Refer to Figure 5-3) and press the dB LIMITS LO key on the keyboard. The LED display will show a gain modifier of approximately 3600. Calculate a revised gain modifier value to obtain the required correction. For example: If the digital multimeter indication were .90 volts (0.4% low) and the dB LIMITS LO key recalled a gain modifier of 3500, the revised gain modifier value would be:

$$1.004 \times 3500 = 3514.$$

Enter this revised gain modifier value by pressing the following keys on the keyboard:

3, 5, 1, 4
dB LIMITS LO
dB LIMITS LO (revised value should appear on the LED display)

g. Reset the control board bit switch to OPERATE MODE 0. Refer to Figure 5-3. Note the indication on the digital multimeter; it should be .98 to 1.00 volts. Repeat steps f and g, if necessary, until the correct indication is obtained.

h. Set the power meter calibrator output to 0.126 mW, and observe the indications on the instrument LED display and on the digital multimeter. The millivolt indication on the digital multimeter should equal the value shown on the LED display ± 1 count. If the digital multimeter indication is incorrect, adjust potentiometer R55 on the input module board as required to provide the proper digital multimeter indication.

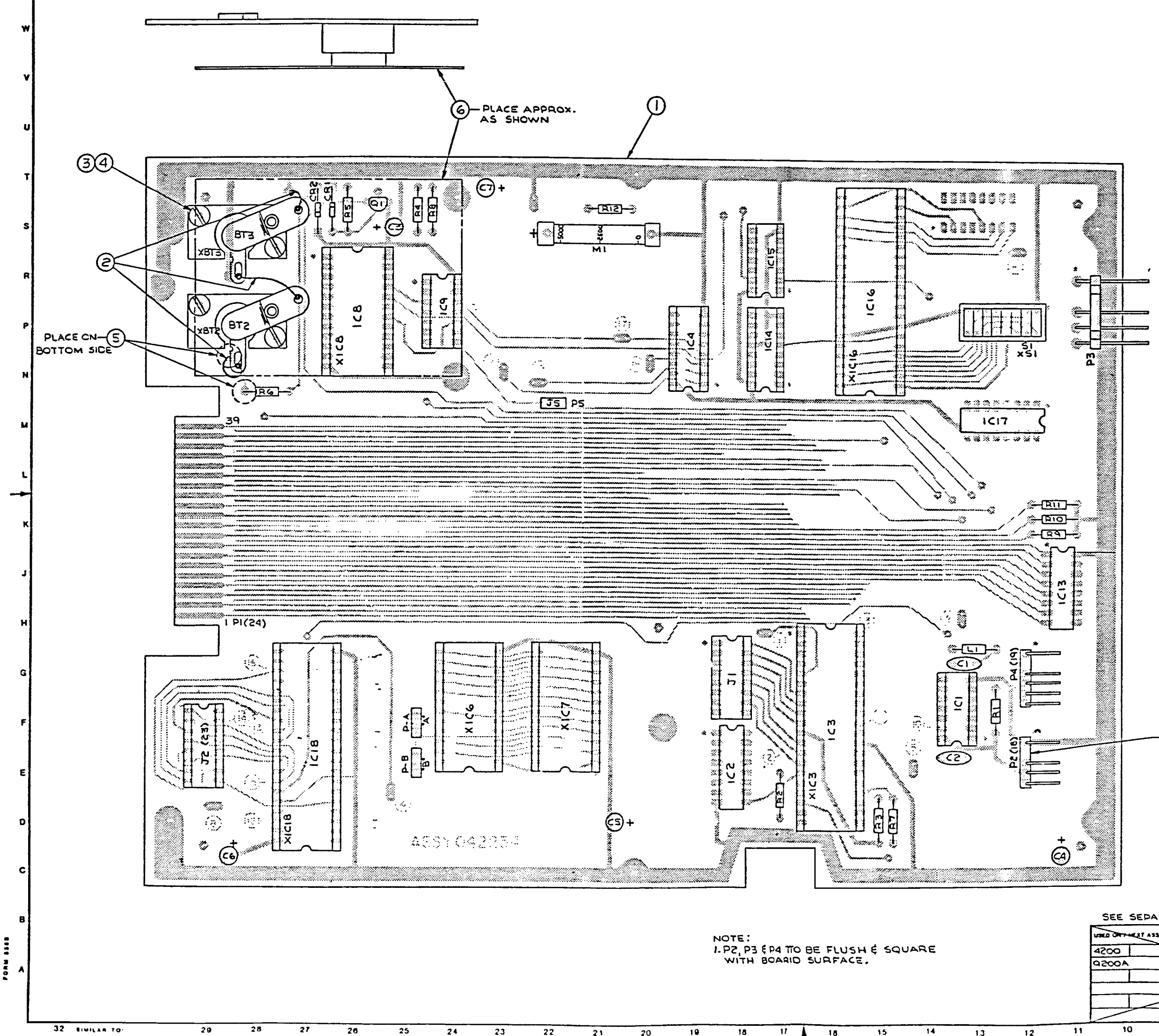

Figure 1
Page 3 of 3

THIS SHEET SPECIFIES PART NUMBER 04223401A

NOTE:
1. P2, P3 & P4 TO BE FLUSH & SQUARE
WITH BOARD SURFACE.

SEE SEPARATE BOM FOR PART NUMBERS

HOLE LEGEND		HOLE LEGEND	
HOLE	TOL ± 0.02 UNLESS NOTED	DESCRIPTION	QTY REF
USED ON NEXT ASSY			
4200			
Q200A			
MATERIAL:		UNLESS NOTED DIMENSIONS IN INCHES TOLERANCES:	
FINISH:		FRAC ± 1/64 .25 & .51	ANGLES ± 1° .25 & .51
DRN	EN	5-4-d/	
CRD			
APP			
SCALE		SIZE	DWG NO.
2:1		D	042234(X)

BOONTON RANDOLPH
ELECTRONICS NEW JERSEY
P.W. ASSY
CONTROL

FORM 8888

SAMPLE CALIBRATION CERTIFICATE

BOONTON ELECTRONICS CORP.

INST SERIAL # 289519BC -TYPE: S/16

DATE: 3/6/87

SENSOR SERIAL # 13525 -TYPE: 6E

EPROMS: 314BC, 365BC, and 322BC used in the 01A option

This is a step by step procedure for reentering the calibration data into the NON VOLATILE MEMORY of this BOONTON ELECTRONICS model 4200 R.F. MICROWATTMETER.

Care should be taken to make sure the BIT SWITCH is configured per instructions. The BIT SWITCH is located under the top cover of the 4200 in the rear left corner. Also be certain that the numbers you enter agree EXACTLY with the numbers on the printout.

Data is entered TOP TO BOTTOM, LEFT TO RIGHT. If a mistake is made depress the CLEAR BUTTON and start at the top of the entry again.

NOTE: C.F.dB IS A DEPRESSION OF THE CAL FAC dB BUTTON.

R.L.dB IS A DEPRESSION OF THE REF LVL dB BUTTON.

BIT SWITCH 1 - OPEN, BIT SWITCH 2 - CLOSED

1	3020	1000	0	1	2	3	4	5	6
CHNL	LO	AUTO	HOLD	HOLD	HOLD	HOLD	HOLD	HOLD	HOLD
			1001	1001	998	995	990	1000	994
			R.L.dB	R.L.dB	R.L.dB	R.L.dB	R.L.dB	R.L.dB	R.L.dB

BIT SWITCH 1 - OPEN, BIT SWITCH 2 - CLOSED

1	3525	1000	2
SENS	HI	C.F.dB	GHz

BIT SWITCH 1 - CLOSED, BIT SWITCH 2 - OPEN

0	1	2	3	4	5	6	7	8	9	10
HOLD	HOLD	HOLD	HOLD	HOLD	HOLD	HOLD	HOLD	HOLD	HOLD	HOLD
4600	4600	4637	4682	4718	4649	4855				
R.L.dB	R.L.dB	R.L.dB	R.L.dB	R.L.dB	R.L.dB	R.L.dB	R.L.dB	R.L.dB	R.L.dB	R.L.dB
4	4	4	7	9	11	0				
CHS	CHS	CHS	CHS	CHS	CHS	CHS	CHS	CHS	CHS	CHS
HI	HI	HI	HI	HI	HI	HI	HI	HI	HI	HI

0	1	2	3	4	5	6	7	8	9	10
AUTO	AUTO	AUTO	AUTO	AUTO	AUTO	AUTO	AUTO	AUTO	AUTO	AUTO
0.0	1.0	2.0	3.0	4.0	5.0	6.0	7.0	8.0	9.0	10.0
GHz	GHz	GHz	GHz	GHz	GHz	GHz	GHz	GHz	GHz	GHz
0.00	.13	.33	.44	.43	.26	.55	.63	.79	.87	.78
C.F.dB	C.F.dB	C.F.dB	C.F.dB	C.F.dB	C.F.dB	C.F.dB	C.F.dB	C.F.dB	C.F.dB	C.F.dB

11	12	13	14	15	16	17	18	19	0
AUTO	AUTO	AUTO	AUTO	AUTO	AUTO	AUTO	AUTO	AUTO	AUTO
11.0	12.0	13.0	14.0	15.0	16.0	17.0	18.0	18.0	
GHz	GHz	GHz	GHz	GHz	GHz	GHz	GHz	GHz	GHz
.68	.39	.37	.16	.20	.19	0.00	.18	.18	
C.F.dB	C.F.dB	C.F.dB	C.F.dB	CHS	CHS	C.F.dB	CHS	CHS	CHS
				C.F.dB	C.F.dB		C.F.dB	C.F.dB	

BIT SWITCH 1 - CLOSED, BIT SWITCH 2 - CLOSED

SAMPLE CALIBRATION CERTIFICATE

BOONTON ELECTRONICS CORP.
DATE: 3/3/87

SENSOR MODEL: 6E-S/16
SERIAL NUMBER: 13525

FREQ (GHz)	REF COEFF (RHO)	SWR	CAL FAC (dB)
1.00	0.012	1.02	0.13
2.00	0.007	1.01	0.33
3.00	0.018	1.03	0.44
4.00	0.026	1.05	0.43
5.00	0.028	1.05	0.26
6.00	0.021	1.04	0.55
7.00	0.024	1.04	0.63
8.00	0.030	1.06	0.79
9.00	0.023	1.04	0.87
10.00	0.006	1.01	0.78
11.00	0.010	1.01	0.68
12.00	0.005	1.00	0.39
13.00	0.019	1.03	0.37
14.00	0.028	1.05	0.16
15.00	0.033	1.06	-0.20
16.00	0.049	1.10	-0.19
17.00	0.065	1.13	-0.00
18.00	0.046	1.09	-0.18

Sensor data is within specifications.

BOONTON CALIBRATOR

DC Range Calibrator

Model 2500

- Accurate, convenient, and self contained.
- Designed for calibrating the Model 4200 and 9200 series instruments.

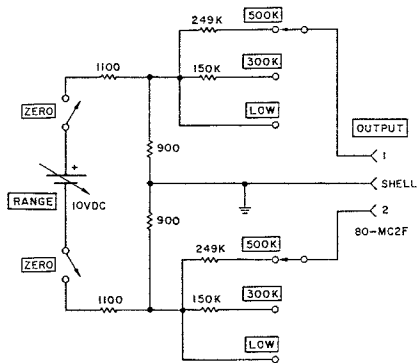

Description

The Model 2500 is a precise, highly stable DC range calibrator that provides the voltage levels and source resistances that are necessary to calibrate the Model 4200 and 9200 series instruments.

Specifications

Ranges and Outputs:

Range	Output Voltage
0	9 μ V
1	90 μ V
2	900 μ V
3	9 mV
4	90 mV
5	900 mV
6A	1.8 V
6B	4.5 V

Accuracy: $\pm 0.15\%$, all ranges.

Source Resistance:
 Low 900 Ω to 1800 Ω .
 300 k Ω 300k Ω $\pm 2\%$.
 500 k Ω 500k Ω $\pm 2\%$.

Temperature Influence:
 Operating: 21 $^{\circ}$ to 25 $^{\circ}$ C.
 Non-operating: -20 $^{\circ}$ to 75 $^{\circ}$ C.

Power Consumption: 7 VA; 100, 120, 220, 240 V $\pm 10\%$, 50 to 400 Hz.

Dimensions: 5.2 in (13.2 cm) high, 8.3 in (21.1 cm) wide, and 11.5 in (29.2 cm) deep.

Weight: 5.9 lbs (2.7 kg).



Boonton Model 25A

PURPOSE AND USE OF EQUIPMENT.

The Model 25A is a precision, solid-state instrument designed to provide accurate 1 MHz signal levels required in the calibration of all Boonton RF microwattmeters, Model 41 and 42 series. Full scale and incremental values for each range are provided, allowing verification and calibration of both full scale and down scale indications.

TRACEABILITY.

The Model 25A is factory calibrated using instrumentation whose accuracy is traceable to the National Bureau of Standards. Periodic calibration of 0 dBm and -9 dBm outputs is accomplished using thermal transfer techniques. The accuracy of other full scale and down scale ranges is determined by precision attenuators which are tested at the factory and should not require periodic calibration.

PERFORMANCE SPECIFICATIONS	
Parameter	Specifications
Power Ranges:	Full Scale -60, -50, -40, -30, -20, -10, 0, ± 10 , ± 20 dBm Down Scale 0 to -9 dB in 1 dB steps
Output Power Accuracy:	± 0.05 dB (at 25°C ± 5 °C for 90 days, 15 minute warm-up)
Temperature Influence:	± 0.001 dB/°C from 0 to 50°C
Harmonic Distortion:	<0.15% total harmonic distortion
Output Frequency:	1 MHz, crystal controlled
Output Impedance:	50 ohms $\pm 0.5\%$
Temperature:	Operating 0 to 50°C Non-operating -20 to 75°C
Input Power:	100, 120, 200, 240 VAC $\pm 10\%$ 50 to 400 Hz, 7 VA
Dimensions:	5.2" high (without feet), 8.3" wide, 11.5" deep
Weight:	7.75 lbs. (3.6 kg)

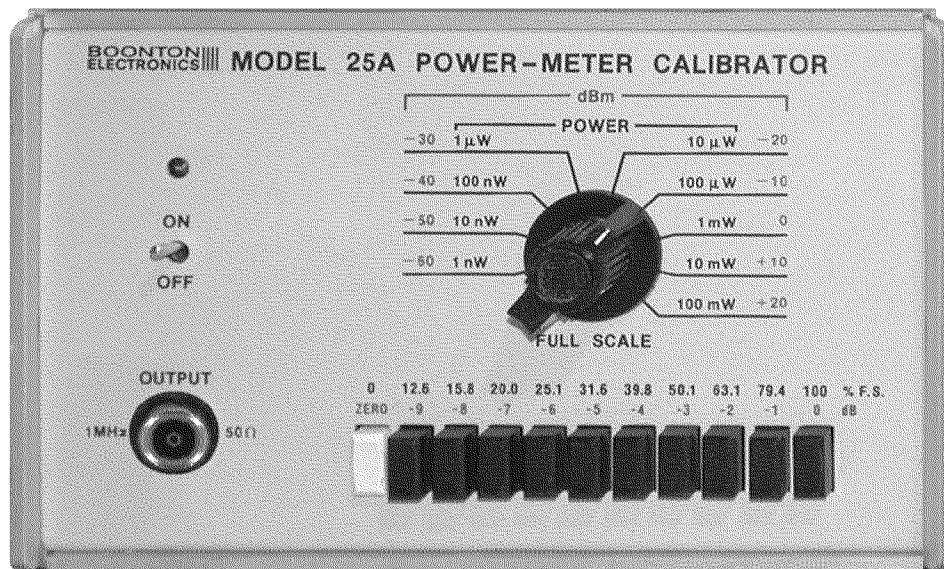

BOONTON

BOONTON ELECTRONICS CORPORATION

BOONTON ELECTRONICS CORPORATION
791 ROUTE 10, RANDOLPH, NJ 07869
(201) 584-1077 TWX: 710-986-8215
FAX: (201) 584-3037